



Mamiya
645AF

Instructions

Congratulations on your purchase of the Mamiya 645 AF Camera.

1

Mamiya pioneered the 645 SLR system camera three decades ago and the Mamiya 645 AF, with its TTL auto-focus, auto-exposure, auto-flash and auto-film winding features, is the latest Mamiya master piece and reflects its long tradition of medium format camera expertise.

2

Combining 35mm handling ease and speed with the advantages of an almost 3x larger image size, it is a full-featured camera, utilizing many digital controls, LCD displays and is ready for the age of digital photography.

3

Its high-tech focal plane shutter with speeds to 1/4000 sec. permits sync flash up to 1/125 sec. and has an exclusive "Safety Retraction" feature, which protects it against accidental damage.

4

The AE Prism Finder with its many features, protected by a sturdy magnesium housing, and also the Power Drive Grip, are now integral components of the diecast aluminum camera body, designed for heavy professional use.

5

All the many features, safety interlocks and other important information are covered in detail in these instructions. It is imperative that you read them thoroughly before you put your camera to work, in order to ensure proper operation and maximum results.

Note:

In order to acquaint yourself with the functions of the camera, you will want to practice without film. Please see bottom of page 37 how the camera can be tested without film.

Special Advice To Professional Photographers

Your Mamiya 645 AF is designed for heavy professional use and will give you a long service life if properly maintained. Your camera and lenses have many moving parts which require periodic lubrication. Its electronic components, too, are subject to wear and tear and are affected by ambient conditions like dust, sand, sea air, heat and moisture.

If cameras had odometers like automobiles, it would be easier to specify servicing schedules. May we suggest that if you shoot thousands of film rolls per year, you send your equipment annually for servicing by the Mamiya distributor in your country.

Names of Parts and Functions

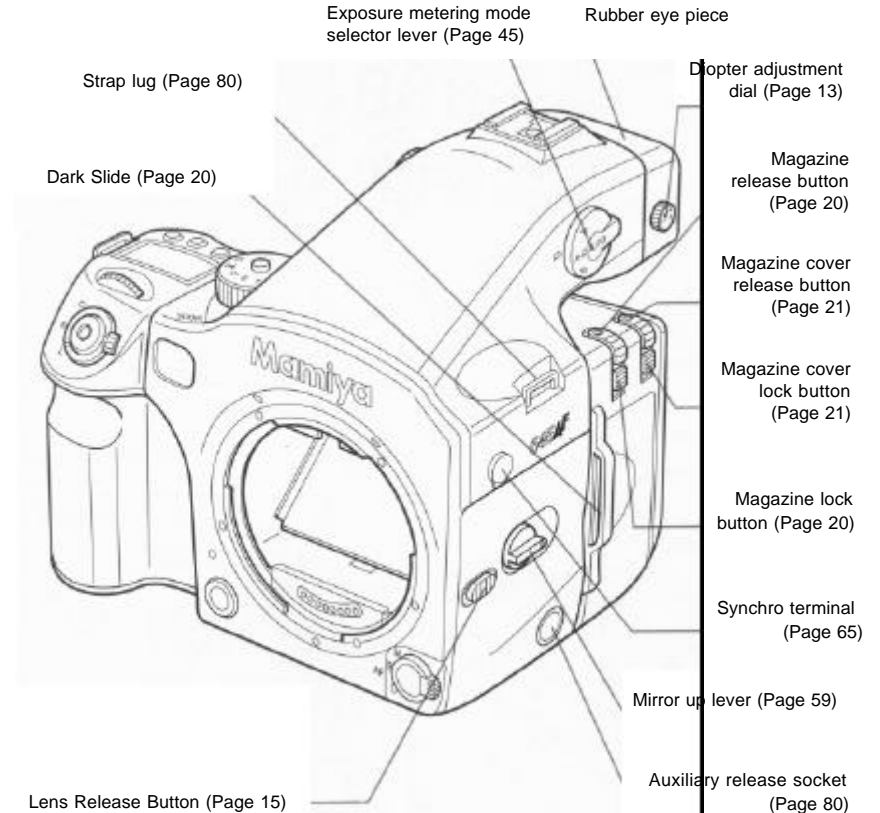
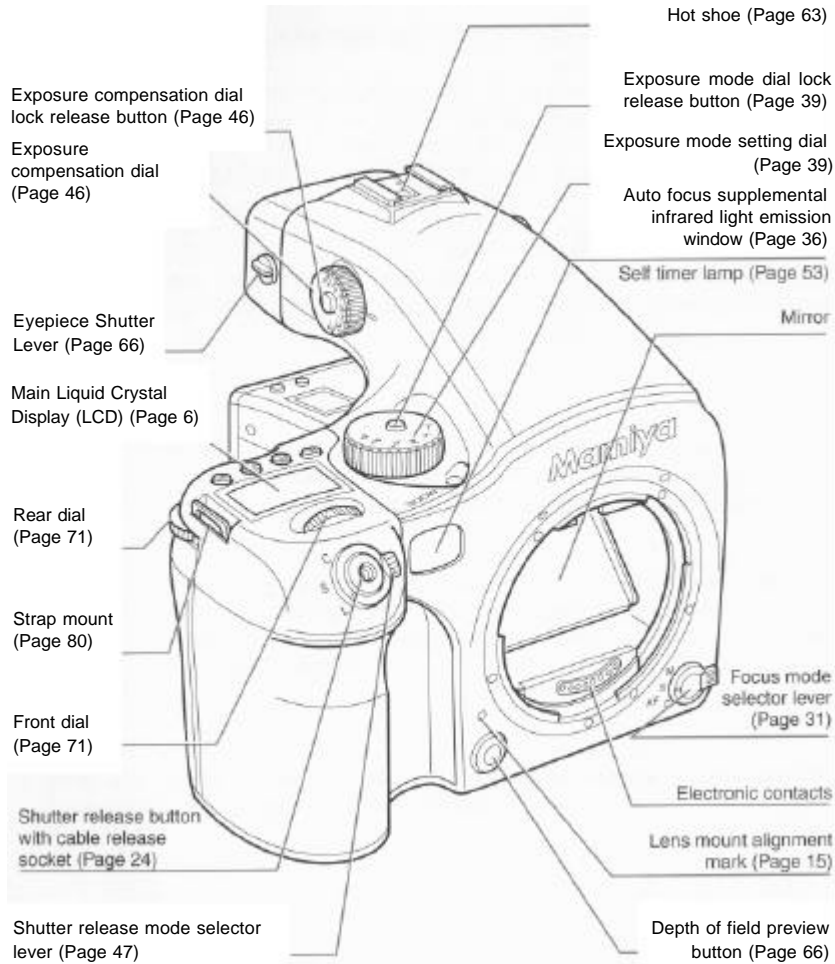

Congratulations on your purchase of the Mamiya 645AF and welcome to the world-wide family of happy Mamiya camera owners!

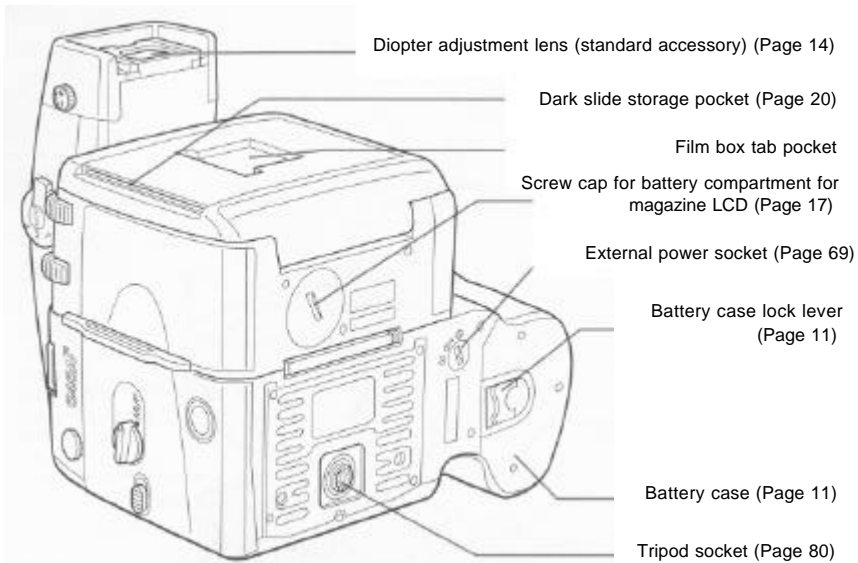

Magazine LCD Panel (Page 6)

Down button (Page 18)

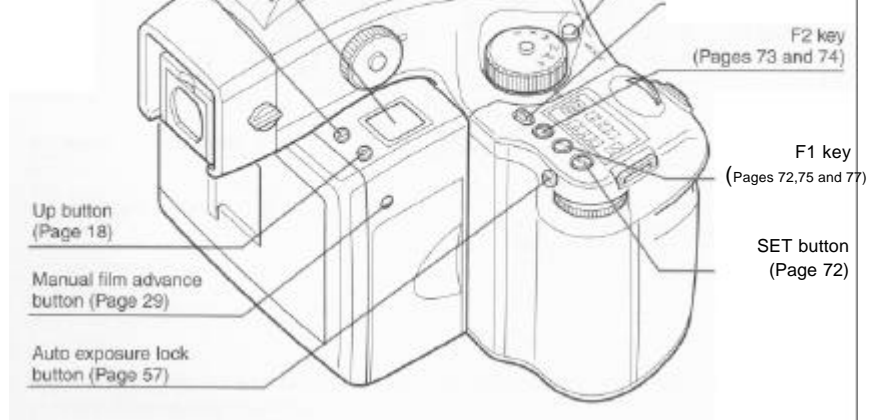

Main Liquid Crystal Display (LCD)

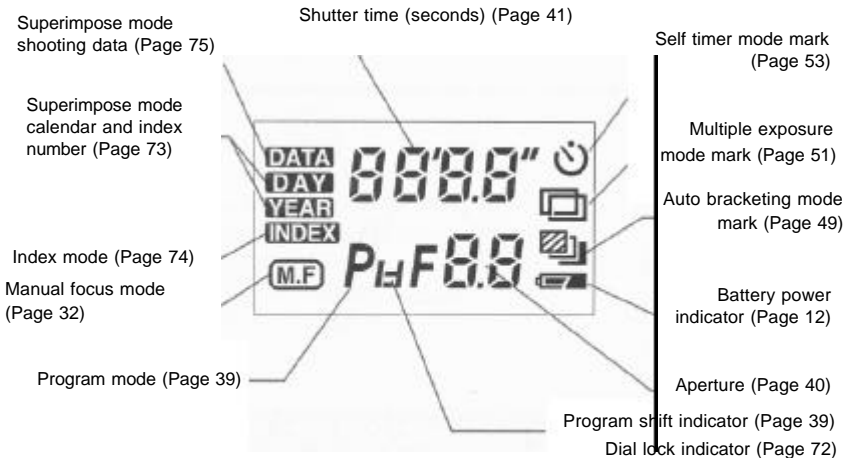

This diagram is for explanatory purposes. The actual display may differ.

Magazine LCD

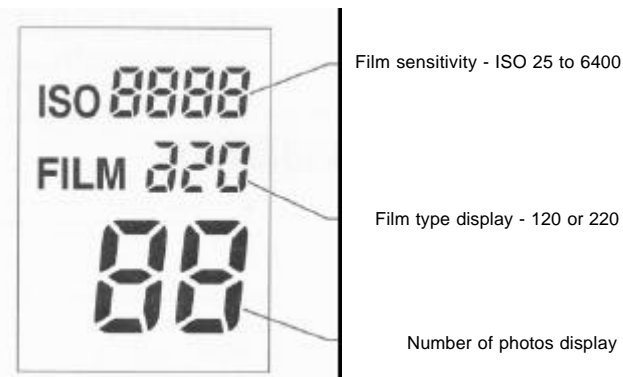

This diagram is for explanatory purposes. The actual display may differ.

Viewfinder with LCD read-outs on bottom

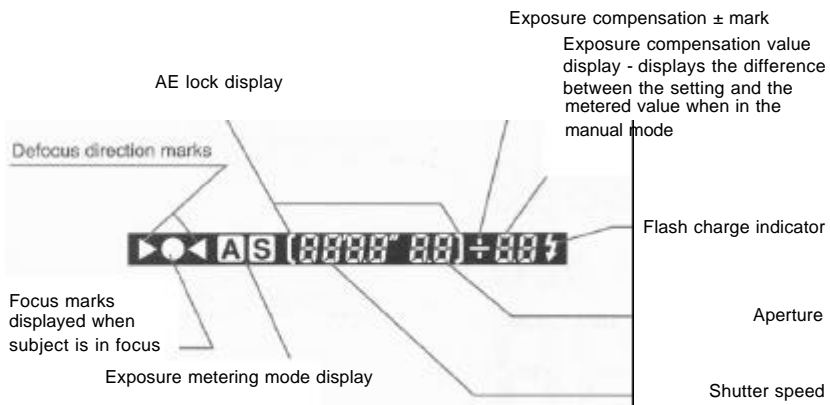
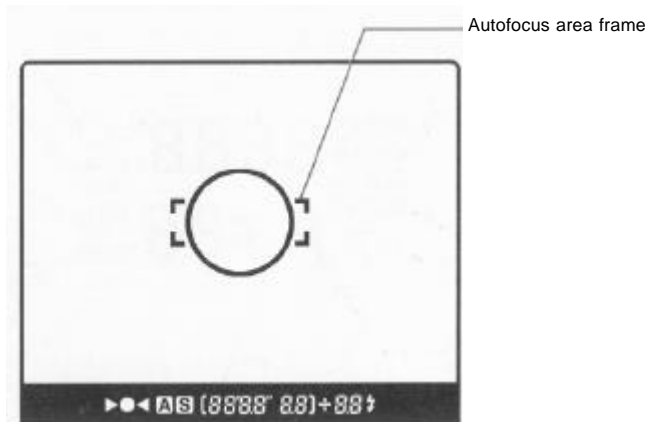

This diagram is for explanatory purposes. The actual display may differ.

Names of Parts and Function	3~5
Main Liquid Crystal Display	6
Magazine LCD	6
Viewfinder with LCD read-outs on button	7
Basic Operation	10~29
Inserting the Batteries	11
Checking the Battery Power	12
Diopter Adjustment	13
Replacing the diopter corrected lens	14
Attaching / Removing the Lens	15~16
Installing the Battery in the Magazine	17
Setting the Film Speed	18
Attaching / Detaching the Magazine.....	19~20
Loading Film in the Magazine	21~23
Shutter Release Button / Holding the Camera	24
Taking Photos in the Full Automatic Mode	25~28
Removing a partially exposed film roll	29
Auto Focus Function	30~36
Single Focus Mode	31
Continuous Focus Mode	31
Manual Focus Mode	32
Manual focusing using the focus mark	33
Subjects With Which Auto Focusing May Not Work	34
Using the Focus Lock Function	35
AF Supplemental Infrared Light	36
Camera Operation Test	37
Exposure Modes	38~43
Program AE	39
Shifting the Program	39
Aperture Priority AE	40
Shutter Priority AE	41
Manual Mode	42~43
X Mode	43
Time Mode.....	43
Exposure Metering and Film Advance Modes	44~47
Average Exposure Metering Mode	45
Spot Exposure Metering Mode	45
Average / Spot Auto Switching Exposure Metering Mode	45

Exposure Compensation	46
Single-Frame Mode / Continuous Mode	47
Additional Shooting Modes	48~53
Auto Bracketing Mode	49~50
Multiple Exposure Mode	51~52
Self Timer Mode	53
Applied Photography	54~69
Extended Exposure Modes	55~56
AE Lock Mode	57~58
Taking Photos with the Mirror Up	59~60
Depth of field	61
Infrared Photography	62
Flash Photography	63~65
Metz Flash SCA3951 System Functions	64
Flash Photography with Flashes other than Metz Flashes	65
Depth of Field Preview /Eyepiece Shutter	66
Changing The Focusing Screen	67
Using the M645 Manual Focus Lenses	68
External Power Supply	69
Date, Electronic Functions, and Miscellaneous	70~86
Electronic Dial Operations	71
Front / Rear Dial Lock Mechanisms	72
Superimposing Data	73~76
Setting the Date and Time	73
Setting the Index Number	74
Selecting the Data to be Superimposed	75
Data superimpose modes	75
Checking the data to be superimposed	76
Changing the Viewfinder Display in the Manual Mode "M"	77
Error Messages	78
If the shutter cannot be released	79
Strap / Using a Tripod / Auxiliary Release Contact	80
Specifications of 645AF	81~82
Common Sense Camera Care and Practice	83~85
The Importance of Proper Maintenance	84
Batteries Care	84
After-Sale Servicing	85
Liquid Crystal Display	86

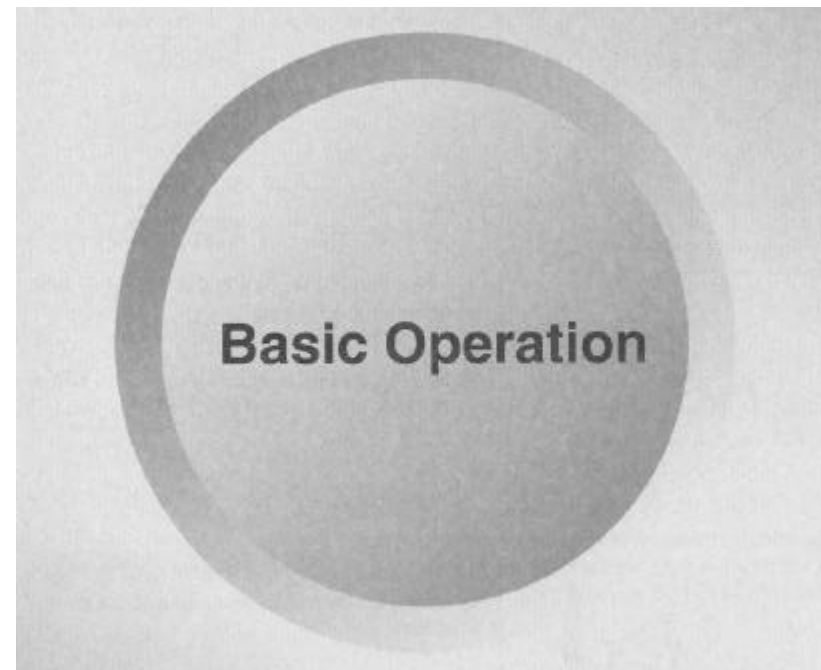

This section describes basic camera operations, how to load film and basic full automatic photography. When we refer to "left or right" we assume you are holding the camera in shooting position.

Inserting the Batteries (The camera will not operate without batteries)

Set the shutter release mode selector lever to "L" (to turn the power off).
Use six "AA" alkaline and lithium batteries.

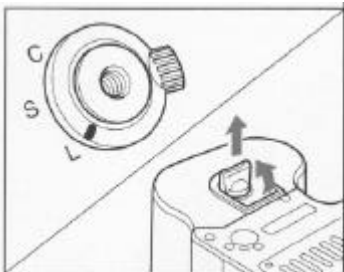

1. Lift the battery case lock lever, turn it counter clockwise and pull out the battery holder.

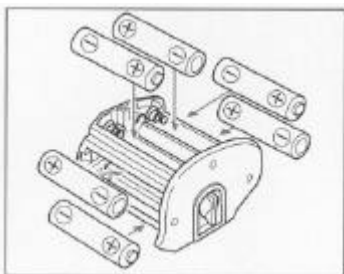

2. Insert fresh batteries with the + and - ends as shown in the drawing.

- **Be sure the batteries are placed with proper polarity**

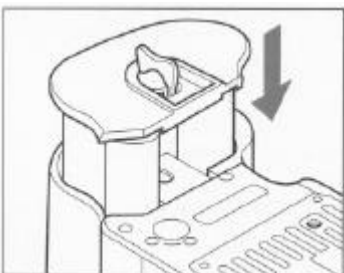

3. Return the battery holder to its case and lock it by turning the lever clockwise. Make sure it is firmly attached.

***After inserting the batteries, set the date and time. (See page 73.)**

Checking the Battery Power

Set the shutter release mode selector lever to "S" (to turn the power on).
Check the battery condition in the lower right corner of the main LCD.



The batteries are sufficiently charged.



There is little power remaining. Have new batteries on hand.
Camera will still operate.



There is very little power remaining. Camera will not operate.
***Set the shutter release mode selector lever to "L" (to turn the power off) and replace the batteries with new ones.**



***When the batteries are spent, "batt" flashes on the main LCD and the viewfinder's LCD when the shutter release button is pressed.**

- **When replacing the batteries, be sure to use six new batteries of the same type. Do not mix different types of batteries or old batteries with new ones.**

Amount of film that can be taken with one set of batteries

At normal temperature (20°C), using new batteries, 120 roll film and under normal usage.

Alkaline batteries	: 150 rolls
Lithium batteries	: 300 rolls

Diopter Adjustment

Look through the viewfinder and make sure that the focus frame (Rectangle with Circle) is in sharp focus. If it is not, turn the diopter adjustment dial in the "-" direction if you are nearsighted, in the "+" direction if you are farsighted. If this is not sufficient you may require an optional diopter corrected lens. See below.

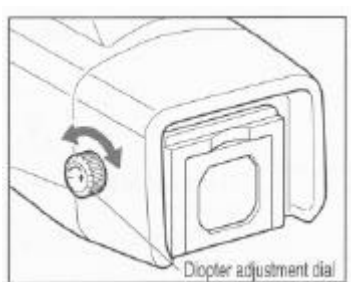

***Point the camera at a bright, plain object such as a white wall when making this adjustment.**

Range of adjustment of diopter corrected lenses (Optional accessory)

Diopter corrected lens	Range of adjustment
DE401 (standard)	-2.5 - +0.5
DE402 (for nearsighted users)	-5.0 - -2.0
DE403 (for farsighted users)	0 - +3.0

Replacing the diopter corrected lens

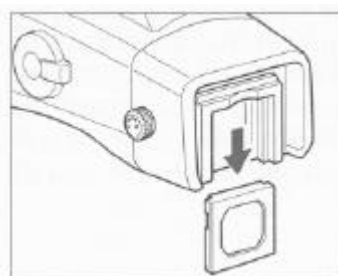

1. Remove the lens supplied with the finder by pulling it downward.

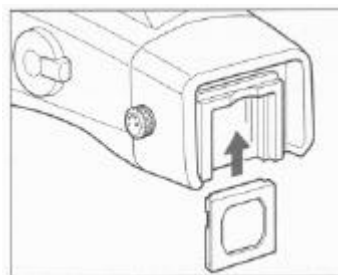

2. Push the replacement diopter corrected lens upward into the viewfinder's eyepiece frame until it clicks into place.

***If there is dirt or dust on the lens surface, remove it with a blower or sweep it off gently with a lens brush.**

***If there are fingerprints or dirt on the lens surface, wipe it off with a piece of clean, soft gauze.**

***Using solvents could discolor the diopter corrected lens frame.**

Attaching/Removing the Lens

Attaching

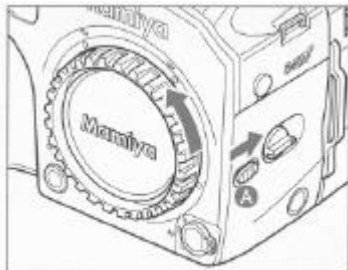

1. Remove the camera's lens opening cap, just like you would remove a lens, by pushing the lens release button "A" backward and then turn the lens cap or the lens itself counter clockwise and lift out.



To remove the front lens cap, squeeze the shiny sections together and lift out.



To remove rear lens cap turn it counter clockwise.

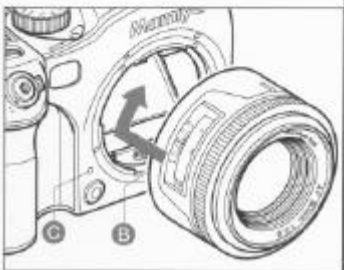

2. Attaching the lens

Align the red alignment dot of the lens (on the shiny flange) with the camera's red dot, fit the lens into the camera and rotate it clockwise until it clicks into place.

***Do not touch the distance ring or other rotating parts during the auto focus operation.**

Removing

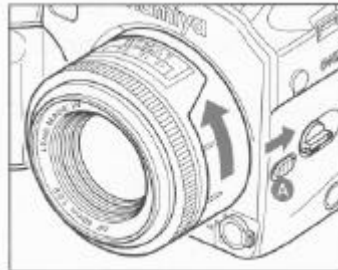

While pushing the lens release button "A", rotate the lens counter clockwise until it stops and lift it off.

***After removing the lens from the camera body, protect both ends by attaching the caps.**

***Oil, dust, fingerprints or water on the electronic contacts could result in malfunction or corrosion. Wipe such impurities off with a clean piece of cloth.**

Installing the Battery in the Magazine

The button battery supplies power to the magazine's LCD when it is detached from the camera. When it is attached the power is supplied by the camera's batteries.

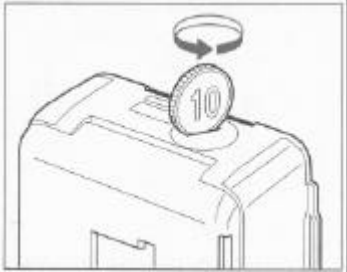

1. Remove the battery compartment cover screw.

Use a coin or suitable screw driver and turn it counter clockwise.

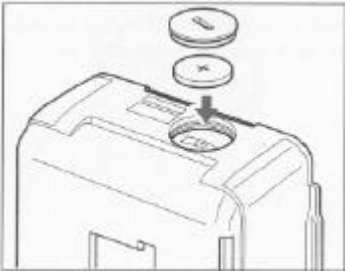

2. Insert a battery.

Insert the battery according to the polarity indication + in the battery compartment, and close the battery cover.

Battery used: Sony CR2032 or equivalent

•Be sure to watch correct polarity

*When the battery is exhausted, remove it immediately and replace with a new battery. Otherwise accidental battery fluid leakage may damage the contacts.

Setting the Film Speed

The film speed (ISO sensitivity value) is the reference for all exposure and must be set correctly. If the set value differs from the actual value of the film in use, under- or overexposure may occur.

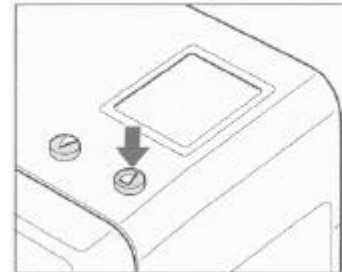

1. Press the ▲ (up) button.

When the LCD panel displays information, press and hold the ▲ (up) button on the bottom part of the LCD for more than 1 second. The ISO indicator will blink.

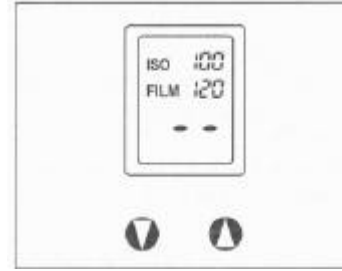

2. Set the film speed.

Set the film speed of the film by pressing the ▲ (up) or ▼ (down) button. To lock the speed setting, press and hold the two buttons simultaneously for more than one second; the film speed will be written in memory in 5 seconds.

*The setting is not complete while the ISO indicator is blinking.

*The information on the film in use, such as the type, ISO sensitivity value and number of exposures, is stored in the back-up memory. However, when the battery capacity has dropped during stand-alone use of the magazine, the information may not be shown by the LCD panel.

*The information on the film (type, ISO sensitivity and number of exposures) is stored in the memory, but when the battery power is low this information may be displayed erroneously. Be sure to replace the batteries with new ones.

Attaching/Detaching the Magazine

When there are no batteries in the camera, the shutter's "Safety Retraction" feature, keeps it in the open position and the magazine's dark slide cannot be pulled out, even when it is attached to the camera. Film winding and shutter release are also blocked in this case.

Attaching

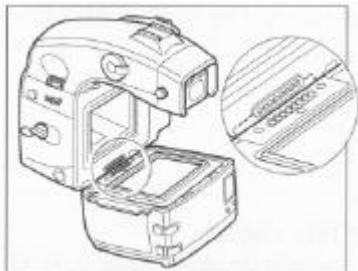

1. Remove the camera's rear body cap and the magazine's protection cap.

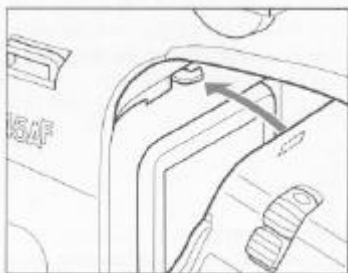

2. Fit the body coupler of the magazine into the bottom channel of the camera, properly centered.

3. Push the magazine against the camera body until it snaps into place. (You will instantly hear the shutter closing)

Detaching



1. Insert the dark slide into the magazine.

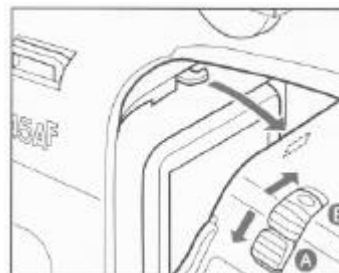

2. With your thumb first push button "A" down and then simultaneously button "B" in. The magazine will separate itself from the camera body.

***When the magazine is removed, the shutter will automatically open, as explained on the previous page, under "Shutter Safety Retraction" Film winding and shutter release are also locked.**

Shutter Safety Retraction

The precision shutter blades are made of very thin hyper-duraluminum and could be damaged if unprotected. Therefore the camera is designed to automatically retract the shutter into the open position when the magazine is removed. When it is reattached the shutter automatically closes and is ready for normal function. (Batteries must be in camera).

Automatic film advance to #1

There is no need to line up the film's paper leader start mark. The magazine automatically advances the film to the first frame (See page 22).

The magazine cannot be attached or detached unless the dark slide is in place.

Loading Film in the Magazine

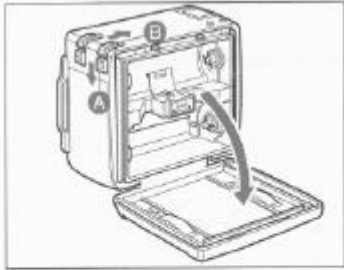

1. Open the back cover of the magazine.
By first pushing the button "A" down and then button "B" simultaneously.

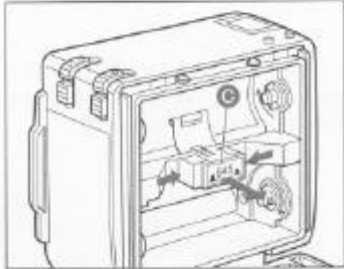

2. Take out the roll-film insert.
Squeeze the center block "645" "C" between your fingers and pull it out.

•When you load film for the first time, remove and discard the protective paper cover which is attached to the film rails in the magazine.

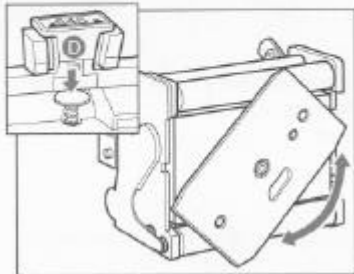

3. Set the film type (120 or 220).
Push and hold the pressure shaft "D" located under the 645 center block. This frees the pressure plate and permits it to be turned and set for either 120 or 220 film.

•Be sure to align the lock pins with the holes on the pressure plate. The film type should be displayed when the film is loaded on the LCD of the magazine.

When the pressure plate (120/220) is set erroneously:

Plate Setting	Loaded Film	Result
120	220 type	<ul style="list-style-type: none"> •Inaccurate focusing. •Film winding after 16 exposures.
220	120 type	<ul style="list-style-type: none"> •Inaccurate focusing. •After the 16th exposure has been made, the shutter can be released a few times until the film's leader paper has run out, but the shutter membrane may be damaged by the leader paper at the film end or by the film's sticker. <p>Insert the dark slide in the magazine and press the shutter button and the forced film advance button simultaneously.</p>

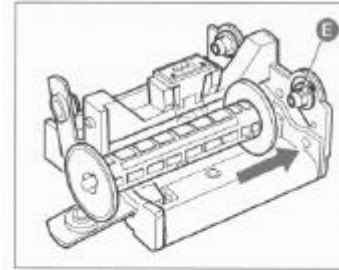

4. Attach an empty spool to the roll-film insert.

Flip the roll-film insert's lower spool clip "SPL" away from the spool, fit an empty spool between take-up spool studs "E", and return the spool clip "SPL" to the original position.

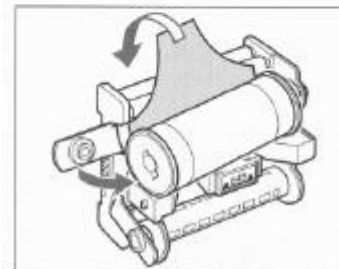

5. Set the film.

Flip the roll-film insert's upper spool clip "FILM" away from the spool, fit a roll of film as shown in the illustration, and return the spool clip "FILM" to the original position.

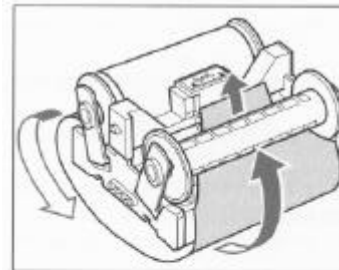
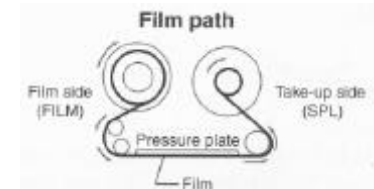

6. Attach the leader paper of the film to the empty spool.

Gently pull out some of the leader paper, insert the tip of the leader paper into the take-up slot of the empty spool, and rotate the spool a few times to wrap the leader tape around it.

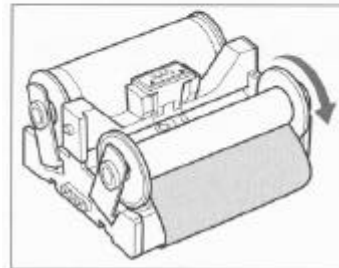

Shutter Release Button/Holding the Camera

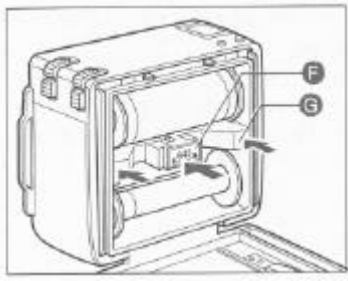

7. Insert the loaded film insert into the magazine.

While squeezing the center latches together, place the film insert, with the feed spool on top, in the magazine and with pressure on the left and right blocks "G" push it into proper position. (You will hear a click).

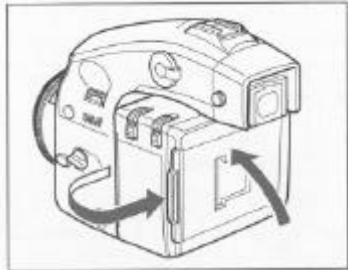

8. Close the back cover.

Push in the upper part of the back cover firmly to close it.

9. After attaching the magazine onto the camera body, pull out the dark slide and press the shutter button halfway; this will feed the film automatically to frame No. 1.

Place the dark slide in the magazine's rear storage pocket

***It is not required to align the film start mark, for the magazine will automatically detect film frame No. 1 from any position.**

***When the magazine is mounted on the camera body, the mirror and shutter which has been freed will be set in position.**

***Do not wrap too much leader paper around the empty spool. Otherwise the film section may be exposed to light.**

***When the magazine is separated from the camera, the power save mode is activated in 5 seconds after the start of stand-alone operation and the LCD panel turns off. To release the power save mode and turn on the LCD panel, press the ▲ (up) button.**

***To prevent accidental film fogging, do not pull out the leader paper too far or load/unload film under direct sunlight.**

***When the film is not wound properly, the counter display disappears and the "--" mark appears in the LCD.**

Shutter Release Button

The shutter release button has a two-step action, A half-press (light pressure) will activate the camera, heavier pressure will release the shutter. When pressed lightly it stops at a certain point. In this manual this position is called the "half-press" position. When half-pressed, the power turns on and the camera becomes functional.



Holding the Camera



Horizontal

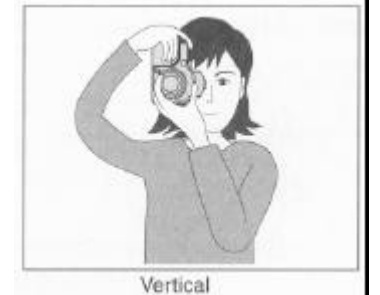

Vertical

Grasp the camera firmly when taking photos. If the camera moves during exposure, the picture will be out of focus.

***Grasp the grip firmly, tuck in both elbows and support the bottom of the camera with your left hand.**

***At slow shutter speeds, or when using the self timer, it is best to use a tripod and cable release or electromagnetic cable release (Optional accessories).**

Taking Photos in the Full Automatic Mode

1. Set the shutter release mode selector lever to "S" (single-frame advance mode).

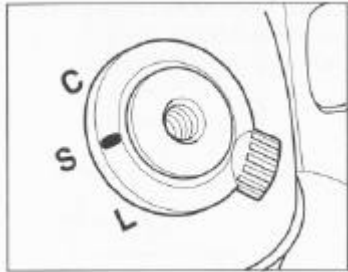

There are two shutter release modes: "S" (singleframe advance mode) and "C" (continuous advance mode). (See page 47.) When set to "L", the power is turned off.

2. Set the focus mode selector lever to "S" (single focus mode). (This control is located at the lower left front of the camera.)

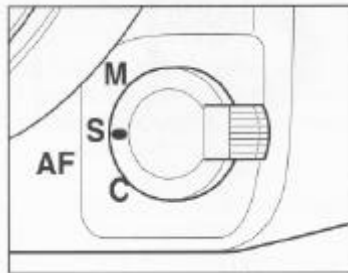

There are three focus modes: "S" (single focus mode), "C" (continuous focus mode) and "M" (manual focus mode).

Focus mode	Focusing
S Single focus mode	Half-press the shutter release button to focus. When the focus mark lights, the focus is fixed and the shutter can be released. (See page 31.)
C Continuous focus mode	Focusing is performed continuously while the shutter release button is half-pressed. The shutter can be released regardless of whether or not the focus mark is lit. (See page 31.)
M Manual focus mode	Focus manually. (See page 32.)

3. Set the exposure mode selector dial to "P" (program auto exposure).

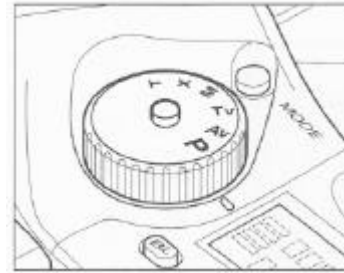

There are four exposure modes: "P" (program AE), "Av" (aperture priority AE), "Tv" (shutter priority AE) and "M" (manual mode).

Exposure mode	Features
P Program AE	The aperture and shutter speed are determined automatically according to the shooting conditions. This mode is best suited for general photography, since it allows you to concentrate on the shooting. The ± 1.0 EV shutter speed can be adjusted by shifting the program. (See page 39.)
Av Aperture priority AE	Set the desired aperture and the camera selects the correct shutter speed. Use this mode to control depth of field. (See page 40.)
Tv Shutter priority AE	Set the desired shutter speed and the camera selects the correct aperture. Use this mode to stop motion. (See page 41.)
M Manual mode	Set this mode when you want to use special combinations of the aperture and shutter speed. (See page 42.)

4. Set the exposure metering mode selector lever to "A-S" (average/spot auto switching).

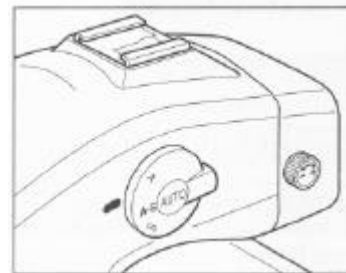

There are three exposure metering modes: "A" in which the average light of the entire picture is measured with emphasis on the center of the picture, "S" in which the light in a spot at the center of the picture is measured, and "A-S" which combines these two to automatically switch the mode according to the extent of difference between the brightness of the light metered in the two modes and sets the distribution ratio of the exposure metering modes within an intermediate range. (See page 45.)

5. Focus.

1. Aim the camera so that the subject is within the focus frame 



2. Half-press the shutter release button.
The focus is adjusted automatically.



When the focus mark ● lights.....The picture is focused.

3. When ● lights, press the shutter release button to make exposure(s).

Defocusing Marks



Flashing: The picture is not focused and the shutter cannot be released.

Either press the shutter release button again to adjust the focus or move the camera to change the position of the focus frame.

6. Unloading the exposed film.

When the fixed number of exposures have been taken, the camera automatically takes up the film till the end and stops. The LCD panel on the magazine should display End now.

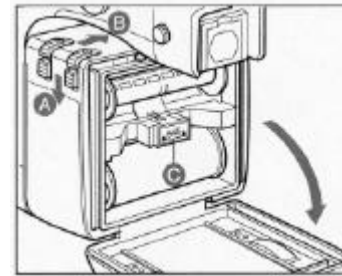

1. Open the back cover.

While holding down the magazine's back cover lock release button "A" push the back cover release button "B" to open the back cover.

2. Remove the roll-film insert.

Squeeze the release latches "C" of the roll-film insert in the film chamber with your fingers and take the roll-film insert out.

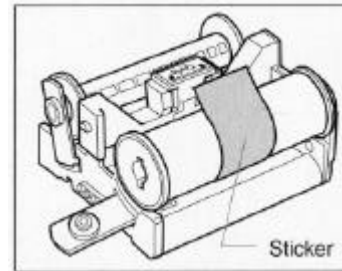

3. Remove the film.

Flip the roll-film clip's spool clip "SPL" away from the spool, and take out the film roll.

4. Fasten the film with a sticker.

After unloading the film roll, attach the provided sticker onto it to prevent unrolling.

*Move the empty spool from the top (FILM) to the lower take-up compartment (SPL), ready for loading the next film roll.

Precautions for Film Unloading

- Do not unload an exposed film in direct sunlight.
- The exposed film should promptly be put in a light tight bag or box and sent to the processing lab as soon as possible.
- Never try to remove the magazine from the camera body in the middle of film winding. Otherwise malfunction will result.

Removing a partially exposed film roll

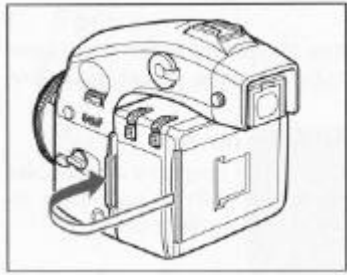

To remove partially exposed film roll, insert the dark slide in the magazine and press the shutter button and the forced film advance button "A" simultaneously. This causes the film to be taken up till the end and the magazine's LCD panel shows "End".

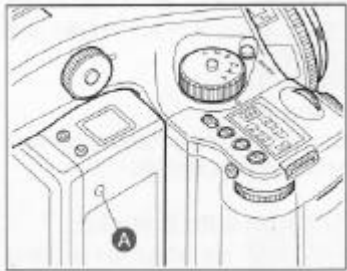

6-exposure film

If you continue photographing after the 8th exposure when using 6-exposure film, the shutter membrane may be damaged by the leader paper at the film end or by the film's sticker. Use the procedure described below.

Photograph in the same way as with 120 film. Eight exposures can be taken. After taking the 8th exposure, insert the dark slide in the magazine, then half-press the shutter release button while pressing in the forced film advance button to wind up the film.

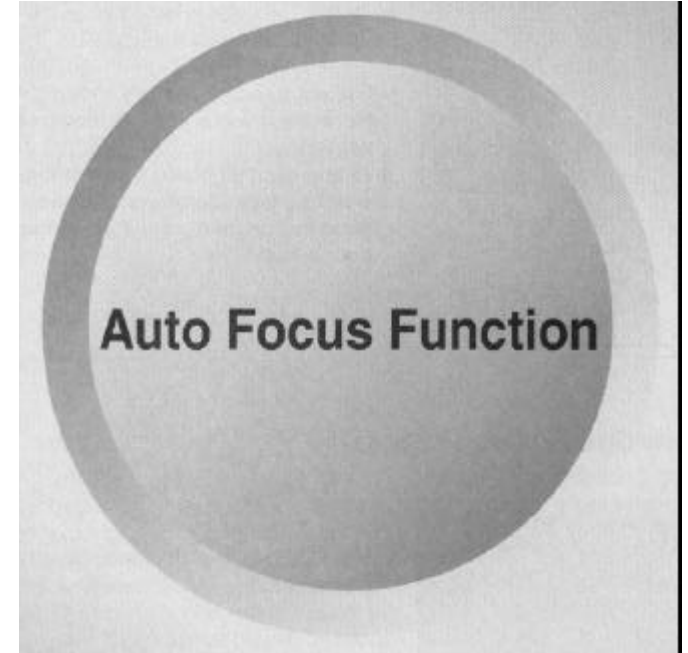

This camera is equipped with a TTL phase difference detection type auto focus function. When the brightness or contrast is low and it is difficult to focus, a supplemental infrared light is emitted automatically. Set the focus mode selector lever to "S" (single focus mode) or "C" (continuous focus mode).

Single Focus Mode (S)

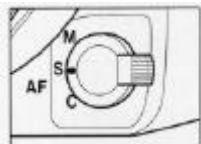

This mode uses the focus priority mechanism. The shutter can be released when the focus mark in the viewfinder is lit. This mode is suited for still subjects. The focus is locked when the ● focus mark lights in the viewfinder's LCD.

***The shutter cannot be released if the subject is not in focus (if the ● focus mark does not light).**

***To take another photo with a different composition, take your finger off the shutter release button then press the shutter release button again.**

Manual Focus Mode (M)

The auto focus function can be turned off so the focus can be adjusted manually.

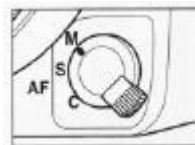
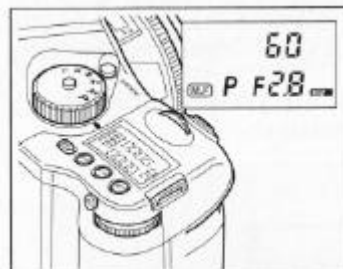

1. Set the focus mode selector lever to "M" (manual focus mode).

Turn the focus mode selector lever to "M" (manual focus mode). "M.F." appears on the main LCD panel liquid crystal display panel.

Continuous Focus Mode (C)

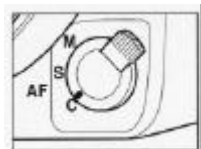

This mode uses the release priority mechanism. The shutter can be released regardless of whether the ● focus mark in the viewfinder's LCD is lit. The focus is adjusted continuously while the shutter release button is half-pressed. This mode is suited for moving subjects.

***The focus is not locked even if the ● focus mark is lit.**

***The shutter can be released even if the ● focus mark is not lit.**

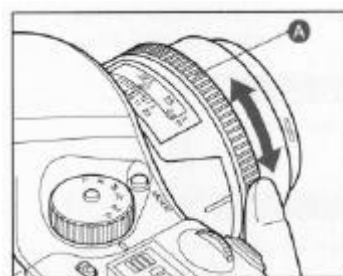

2. Adjust the focus.

Turn the lens focusing ring "A" and adjust the focus to the subject. When the subject is in focus, the ● focus mark lights on the viewfinder's LCD.

Manual focusing using the focus mark. (Focus confirmation method)

With this camera, a focus mark ● lights in the viewfinder's LCD when the picture is in focus. With the shutter release button half-pressed, turn the lens focusing ring to focus on the subject. When the subject is in focus, the ● focus mark lights in the viewfinder's LCD.

If ► is lit in the viewfinder's LCD, the camera is focused on a point behind the object. If ◀ is lit, the camera is focused on a point in front of the object.



In focus



Turn the focusing ring clockwise.

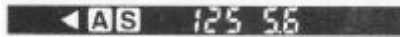

Turn the focusing ring counterclockwise.

*Use this method when shooting in the manual focus mode and when using the M645 lenses. This method can be used when the lens aperture is f/5.6 or larger.

Subjects With Which Auto Focusing May Not Work

The auto focus function requires subject contrast. Auto focusing may not be possible with the types of subjects described below. If this is the case, either switch to the manual focus mode and focus manually or point the camera at an object the same distance as the object you want to photograph, lock the focus using the focus lock mechanism, then take the picture. (See next page)

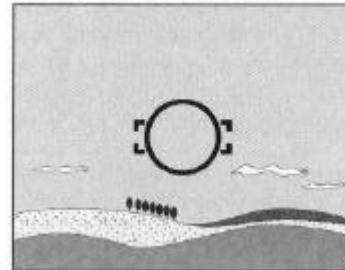

❶ When differences between light and shade are not clear (blue skies, white walls and other objects with no contrast)

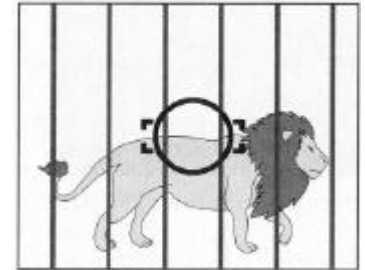

❷ When there are two or more objects at different distances within the focus frame (animals in cages, etc.)

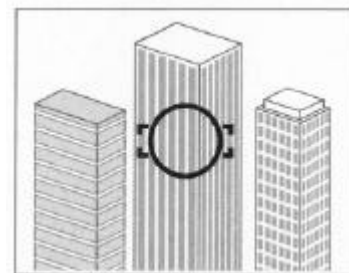

❸ Subjects with continuous repeated patterns (building exteriors, blinds, etc.)

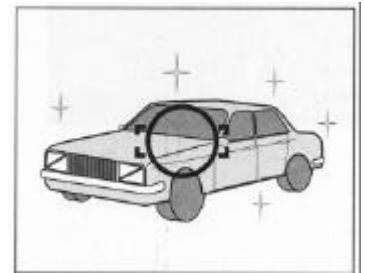

❹ Brightly shining subjects like the sun or light sources or objects in which these are reflected (car bodies, water surfaces, etc.)

❺ When the object on which you want to focus is far smaller than the focus frame

Using the Focus Lock Function

If the object on which you want to focus is not in the focus frame, the camera focuses on the background at the middle. In such cases use the focus lock mechanism to lock the focus before taking the picture.



1. Set the focus mode selector lever to "S".

Put the object on which you want to focus in the focus frame [] and half-press the shutter release button. The ● focus mark lights and the focus is locked.

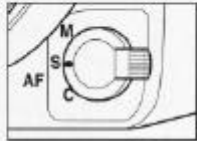

2. Change the composition.

With the shutter release button half-pressed, move the camera to achieve the desired composition, then release the shutter.

AF Supplemental Infrared Light

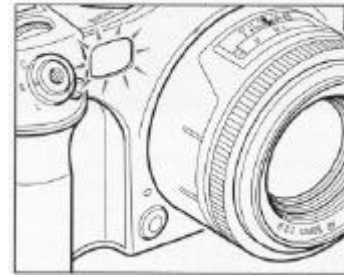

When the subject is dark or the contrast is low and the camera is having trouble focusing automatically, a red lamp may light on the front of the camera when the shutter release button is half-pressed. This is a supplemental light that assists the camera's auto focus function.

*The AF supplemental infrared light is only emitted when the focus mode is set to "S" (single focus mode).

*The AF supplemental infrared light's reach is limited. It does not reach distant subjects.

Range: 9 meters (when using an 80mm f/2.8 lens)

*When using a bellows lens hood (sold separately) with a diameter larger than that of the lens, focus before mounting the hood.

Camera Operation Test

This is a simple way to test the camera and autofocus without film.

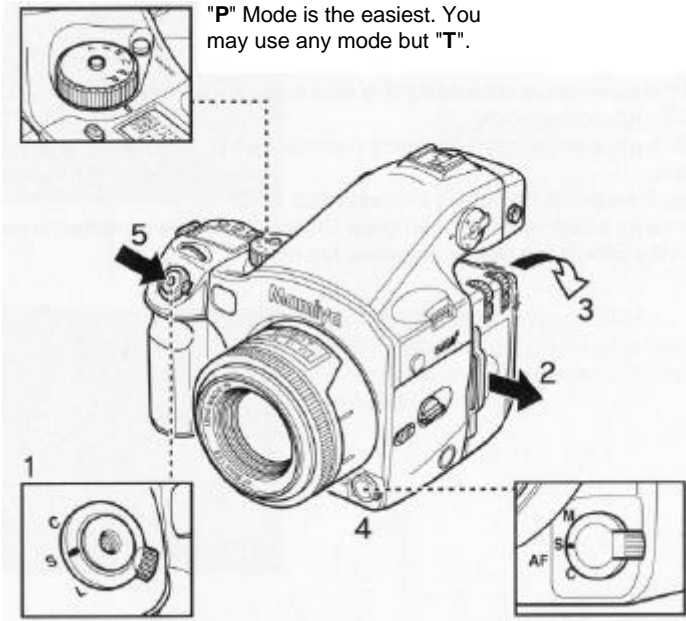

"P" Mode is the easiest. You may use any mode but "T".

1. Set the shutter release mode selector lever to "S" (to turn the power on).
2. Remove the Dark Slide from the magazine.
3. Open the back cover.
4. Set the autofocus modeselector lever to "S".
5. Release the shutter.

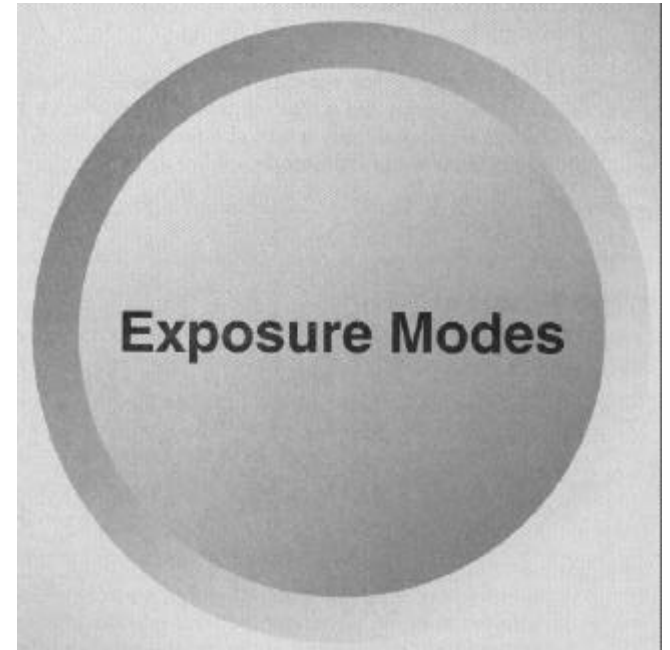

This camera offers you a selection of four exposure modes - program AE (automatic exposure), aperture priority AE, shutter priority AE and the manual mode.

Program AE (P)

The aperture and shutter speed are determined automatically for the optimum exposure, according to the existing ambient light. This mode is best suited for general photography, allowing the user freedom to concentrate on the subject.

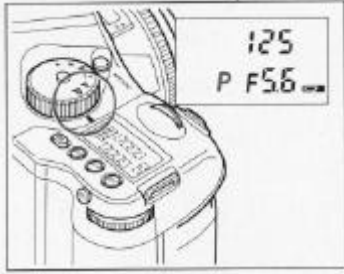

Turn the exposure mode setting dial and set it to "P" (program AE).

***In the "X" exposure mode the lock function is activated. Press the exposure mode dial lock release button while turning the exposure mode setting dial.**

Shifting the Program

Use "PL" to record subjects with depth using a smaller aperture (landscapes, etc.), "PH" to record moving subjects with a high shutter speed.

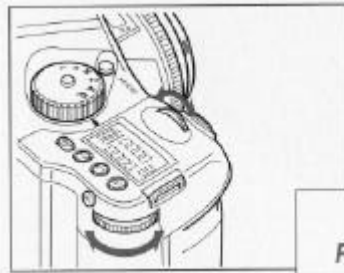

Turn the front or rear dial to shift the shutter speed between the +1.0 EV high speed side "PH" and -1.0 EV low speed side "PL".

PL = Program Low / slower (low) shutter speeds
PH = Program High / faster (high) shutter speeds

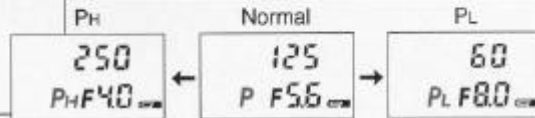

***If the aperture flashes on the main LCD and in the viewfinder display when the program is shifted, the proper exposure cannot be achieved. Please select a different Program mode.**

*** When the Program mode is shifted, the aperture changes along with the shutter speed to maintain the proper exposure.**

Aperture Priority AE

Set the desired aperture and the camera selects the optimum shutter speed accordingly. Use the Av mode to maintain specific control over depth of field, i.e. taking portraits or landscapes.

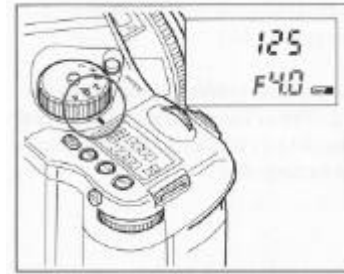

1. Turn the exposure mode setting dial and set it to "Av" (aperture priority AE).

*** In the "X" exposure mode the lock function is activated. Press the exposure mode dial lock release button while turning the exposure mode setting dial.**

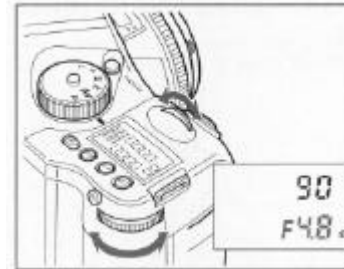

2. Turn the front or rear dial to set the desired aperture.

The aperture value is adjusted in 1/2 stop increments.

***The shutter speed value on the main LCD and in the viewfinder display will flash when photographing objects that are too bright or too dark for proper exposure. The proper exposure cannot be achieved at the present settings. Change the aperture value by turning the front or rear dial until the shutter speed value stops flashing and remains lit.**

Shutter Priority AE

Set the desired shutter speed and the camera selects the optimum aperture accordingly. Use the Tv mode to maintain specific control over action, i.e. shooting sporting events or deliberately blurring your subject.

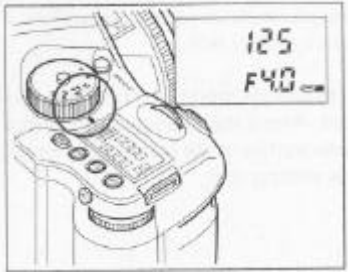

1. Turn the exposure mode setting dial and set it to "Tv" (shutter priority AE).

***In the "X" exposure mode the lock function is activated. Press the exposure mode dial lock release button while turning the exposure mode setting dial.**

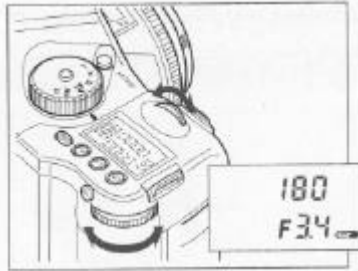

2. Turn the front or rear dial to set the desired shutter speed.

The shutter speed value is adjusted in 1/2 stop increments.

***The aperture value on the main LCD and in the viewfinder display will flash when photographing objects that are too bright or too dark for proper exposure. The proper exposure cannot be achieved at the present settings. Change the shutter speed value by turning the front or rear dial until the aperture value stops flashing and remains lit.**

Manual Mode (M)

Use the manual mode "M" when you desire to have complete control over shutter speed and aperture settings. This mode is also best utilized in combination with an independent hand-held exposure meter.

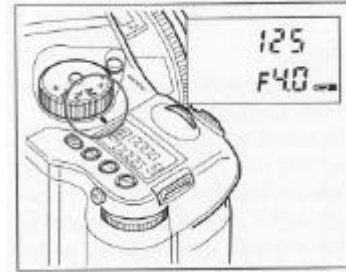

1. Turn the exposure mode setting dial and set it to "M" (manual mode).

***In the "X" exposure mode the lock function is activated. Press the exposure mode dial lock release button while turning the exposure mode setting dial.**

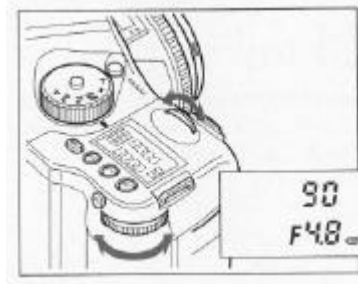

2. Turn the rear dial to set the desired aperture. The aperture value is adjusted in 1/2 stop increments.

3. Turn the front dial to set the desired shutter speed. The shutter speed value is adjusted in 1/2 stop increments.

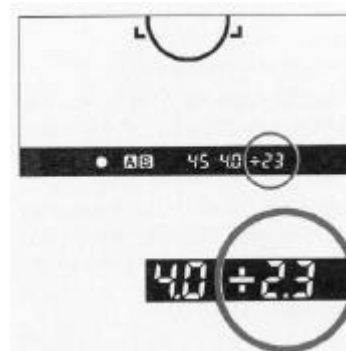

4. When the shutter release button is half-pressed, the difference between the manual settings and the metered value is displayed in the viewfinder's LCD panel. The value is displayed in 1/3 stop increments within a range of ± 6 EV.

***For example, "+2.3" indicates +21/3EV, "-5.7" indicates -5 2/3 EV.**

***If the manual settings and the metered value are the same, nothing is displayed as a difference in the viewfinder's LCD panel.**

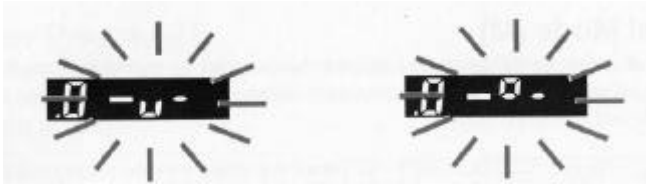

*If the difference between the manual setting and the metered value is greater than 6 EV, "-U-" (under) or "-O-" (over) flashes in the viewfinder's LCD panel.

*Exposure compensation cannot be used while in the manual mode.

*When the difference between the manual setting and the metered value is displayed in the viewfinder's LCD panel while in the manual mode and the exposure compensation dial is set to a position other than "0", the value displayed is the difference between the manual setting and the metered value plus the exposure compensation value. This has no effect on the exposure.

X Mode (X)

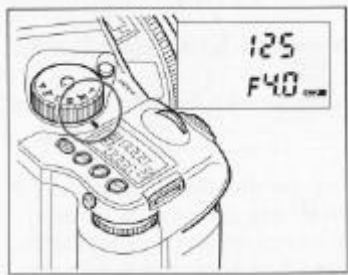

This mode fixes shutter speed at the sync speed of 1/125 sec. In this position, the dials lock and cannot be rotated. (See pages 63-65.)

Time Mode (T)

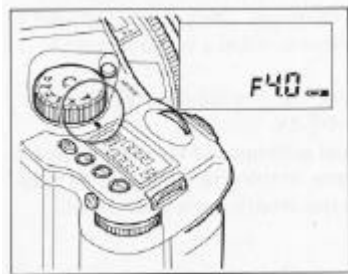

This is a mechanically controlled mode for long exposures. It consumes no battery power. (See pages 55-56.)

*In the "X" exposure mode the lock function is activated. Press the exposure mode dial lock release button while turning the exposure mode setting dial.

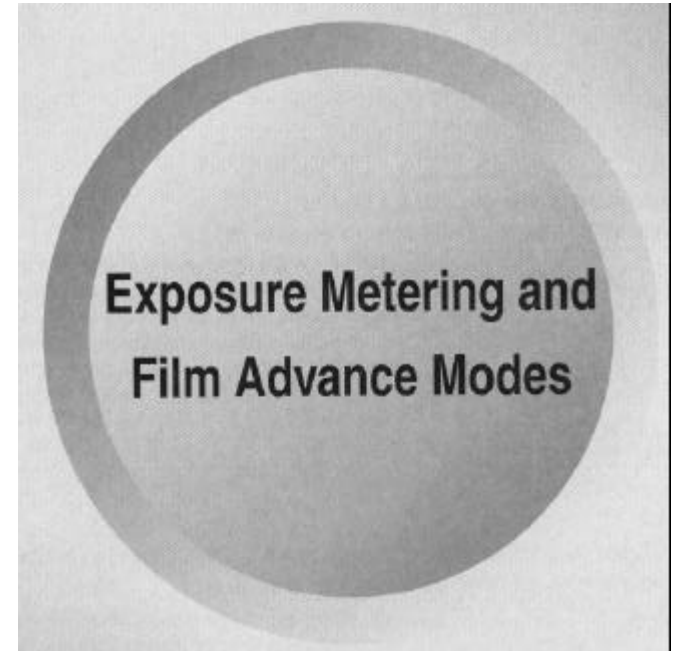

There are three exposure metering modes: "A" in which the average light of the entire picture area is measured with emphasis on the center, "S" in which the light in a spot at the center of the picture area is measured, and "A-S" which combines these two to automatically switch the mode according to the extent of difference between the brightness of the light metered in the two modes. The distribution ratio of the exposure metering modes is set within an intermediate range. See pages 45-46 for Exposure Metering modes. See page 47 for Film Advance modes.

Exposure Compensation

Average Exposure Metering Mode (A)

(Set the exposure metering mode selector lever to "A".)

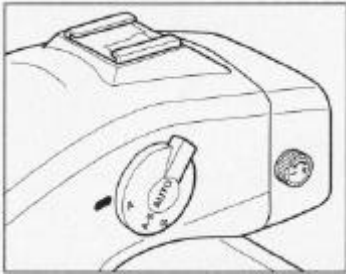

The average light of the entire picture area is measured, with emphasis on the center.

Spot Exposure Metering Mode (S)

(Set the exposure metering mode selector lever to "S".)

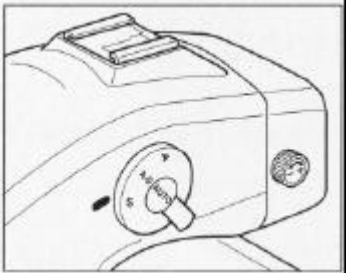

The light in the circle at the center of the picture area is measured to determine the exposure. This mode is best suited for strongly backlit subjects, or when you desire to measure a specific area. When the spot you want to measure is not at the center of the picture, use the AE lock function. (See pages 57-58 AE Lock Mode.)

Average/Spot Auto Switching Exposure Metering Mode (A-S AUTO)

(Set the exposure metering mode selector lever to "A-S".)

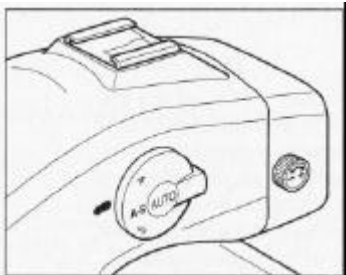

With the A-S metering mode, average or spot exposure metering is selected automatically and the appropriate exposure is set accordingly. The spot mode is selected automatically when the brightness within the spot metering area is lower than the brightness of the average metering area by about 1.5 EV or greater. The average mode is selected when the spot exposure metering value is the same or brighter than the average value. When the difference between the spot value and average value is between 0.75 and 1.5 EV, the appropriate exposure is achieved at an intermediate value.

In some situations, such as a great difference between the subject and background brightness or overall subject tones that will not meter correctly because they are all black or white, the resulting photograph may be under- or overexposed. When this occurs, use the exposure compensation function. Exposure compensation can also be used when you want to intentionally create overexposed or underexposed pictures.

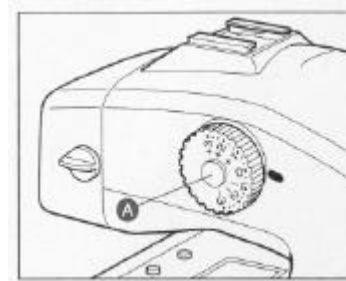

Turn the exposure compensation dial while pressing the exposure compensation dial lock release button "A" located on the right side of the viewfinder. The exposure can be adjusted within a range of ± 3 EV in 1/3 steps. Be sure to set the exposure compensation dial back to the "0" position once you are finished taking photos with exposure compensation.

Display of the exposure compensation in the viewfinder's LCD panel

Exposure mode	Exposure compensation display
P	Program AE
Av	Aperture priority AE
Tv	Shutter priority AE
M	Manual mode
X	Synchro mode
T	Time mode

The setting is displayed.

The difference between the metered value and the set exposure value is displayed. The exposure compensation function cannot be used.

Not displayed.

•If a polarizing filter is necessary, use a circular polarizing filter. A linear polarizing filter is not compatible with the Mamiya 645 AF and its operations.

Single-Frame Mode/Continuous Mode

Single-Frame Mode

The film is advanced one frame at a time each time the shutter release button is pressed.

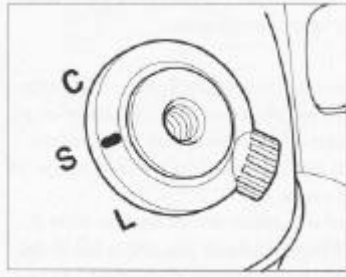

Set the shutter release mode selector lever to "S".

Continuous Mode

Photographs are taken continuously as long as the shutter release button is pressed.

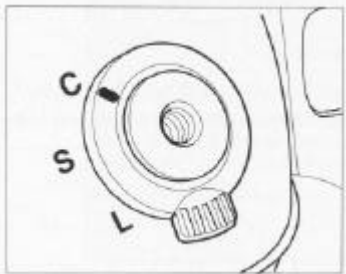

Set the shutter release mode selector lever to "C". Photographs are taken continuously at a rate of about 1.2 frames per second. If you reach the end of the film when shooting in the continuous mode, "End" flashes on the Magazine LCD panel.

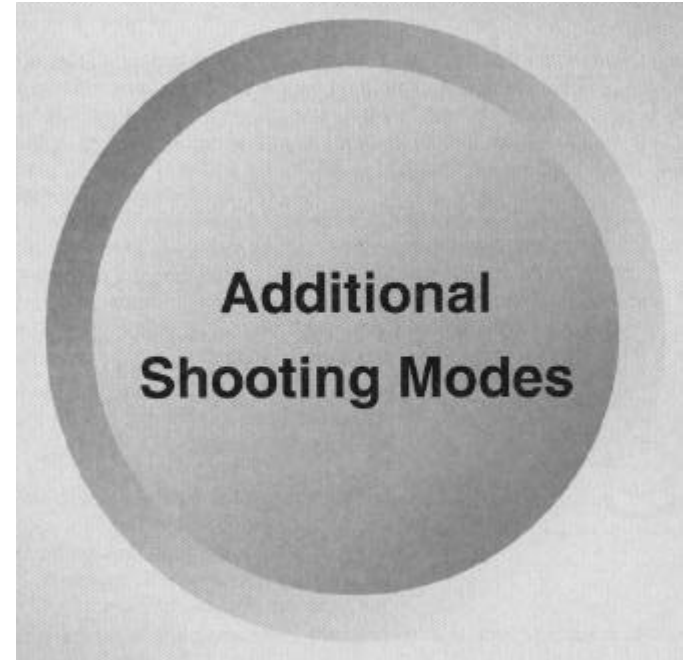

The mode setting button can be used to set three modes: the auto bracketing mode, the multiple exposure mode and the self timer mode.

NOTE: Each of these modes can be used independently. You cannot use these modes simultaneously.

Auto Bracketing Mode

In situations which are difficult to confidently meter for exposure, use the Auto Bracketing function. In this mode, three frames are taken successively with different exposures set automatically (overexposure, standard and underexposure).

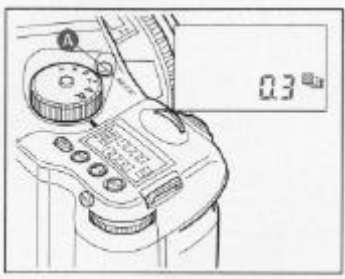

1. Turn the mode setting dial and select "P", "Av" or "Tv".

2. Press the mode setting button "A" once to set the auto bracketing mode.

The auto bracketing mark  and the initial setting 0.3 appear on the Main LCD panel.

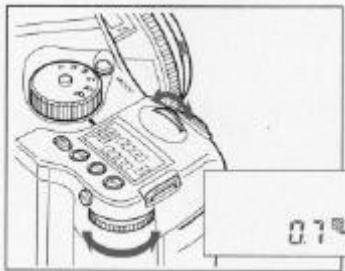

3. Turn the front or rear dial to set the exposure compensation steps.

When the dial is turned, the exposure compensation step switches between 1/3, 1/2, 2/3 and 1 (displayed 0.3, 0.5, 0.7 and 1.0). The setting is registered after 5 seconds or when the shutter release button is pressed.

4. Press the shutter release button once. Three photos are taken successively.

All exposures in the Auto Bracketing mode are made in the following order: overexposure, normal exposure and underexposure.

***The auto bracketing mode is automatically canceled once the three photos are taken.**

***When the shutter release mode selector lever is set to "L" (power off), all the settings aside from the selected mode are reset to the default values.**



Automatic exposure operation in the auto bracketing mode

Exposure mode		Operation
P	Program AE	The shutter speed changes.
Av	Aperture priority AE	The shutter speed changes.
Tv	Shutter priority AE	The aperture changes.

***In the auto bracketing mode, three photos are taken in succession. Be sure to fix the camera in place, for example by using a tripod.**

★If there are fewer than three frames left on the film when the auto bracketing is set and the shutter release button is pressed, the shutter is not released, "NO"  flashes on the main LCD panel and the auto bracketing is automatically canceled.

★When the shutter release mode is set to "C" (continuous advance mode), three bracketed photos are made in back-to-back succession as long as the shutter release button is pressed.

★To cancel the auto bracketing mode, press the mode setting button  three times. The auto bracketing mode is canceled and the camera is reset to the normal shooting mode. The "  " symbol will disappear from the main LCD panel.

Multiple Exposure Mode

With the multiple exposure mode, the same frame of film can be exposed multiple times.

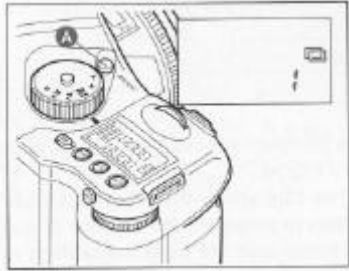

1. Press the mode setting button "A" twice to enter the multiple exposure mode.

The multiple exposure mode mark  and the number of additional exposures ("1" at first) appear on the main LCD panel.

2. Turn the front or rear dial to set the number of additional exposures.

The number of additional exposures can be set between 1 and 5. The setting is registered after 5 seconds or when the shutter release button is pressed.

***For example, when the number of additional exposures is set to "2", the same frame of film will be exposed three times, after which the film is advanced.**

3. Press the shutter release button. The current frame is exposed multiple times.

The multiple exposure mode is canceled automatically once the set number of additional exposures have been taken.

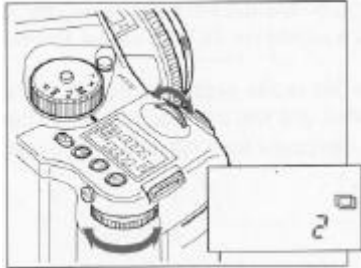

***The multiple exposure mode mark is displayed on the main LCD panel during the multiple exposure mode.**

***The same frame is exposed multiple times, so exposure compensation may be required .**

***To check the number of additional exposures remaining during the multiple exposure mode, press the mode setting button "A" once. The remaining number of additional exposures is displayed on the external liquid crystal display panel.**

***If you wish to make more than 5 additional exposures, the number of additional exposures can be incremented during the multiple exposure mode by pressing the mode setting button "A" and turning the front or rear dial.**

***When the shutter release mode is set to "C" (continuous advance mode), once the set number of additional exposures have been taken, the camera is reset to the normal shooting mode.**



***To cancel the multiple exposure mode, press the mode setting button "A" twice. The multiple exposure mode is canceled and the camera is reset to the normal shooting mode.**

***When the shutter release mode selector lever is set to "L" (power off), all the settings aside from the selected mode are reset to the default values.**

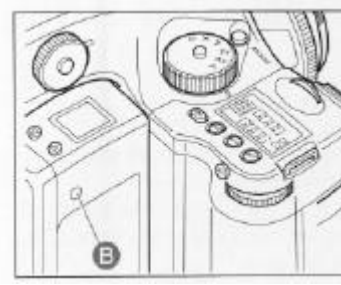
Canceling the Multiple Exposure Mode



To cancel the multiple exposure mode before all the additional exposures have been taken, with the dark slide removed, half-press the shutter release button while pressing the roll film holder's manual film advance button "B".

★When the roll film holder is removed while in the multiple exposure mode, "-no- flashes on the external liquid crystal display panel, the display returns to normal after 3 seconds and the multiple exposure mode is canceled, but the camera continues to be in the multi exposure mode for one more exposure when the magazine is reattached. (The multiple exposure continue mode mark " is displayed on the magazine LCD panel.)

Self Timer Mode

With this function, under the default setting the shutter is released 10 seconds after the shutter release button is pressed. The self timer lamp flashes slowly for the first 7 seconds, then flashes quickly for the last 3 seconds before the shutter is released. Use this function to take group photos or to photograph yourself.

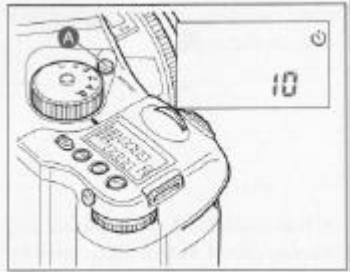

1. Fix the camera to a tripod.
2. Press the mode setting button "A" three times to set the self timer mode.

The self timer mark  and the initial setting (10 for 10 seconds) are displayed on the external liquid crystal display panel.

3. The number of seconds before the shutter is released can be changed by turning the front or rear dial. The number of seconds can be set between 3 and 60, in steps of 1 second from 3 to 10 seconds, in steps of 10 seconds from 10 to 60. The setting is registered after 5 seconds or when the shutter release button is pressed.

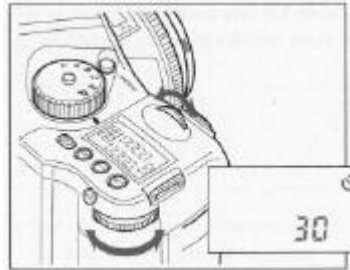

4. Looking through the viewfinder, determine the composition, check that the focus is set properly, then press the shutter release button. The shutter is released after the set number of seconds.

* To cancel the self timer mode after pressing the shutter release button, either press the mode setting button "A" or turn the exposure mode setting dial. Changing the exposure mode does not change the set self timer operating time.

*If there is a bright light source behind the camera or if the shutter release button is pressed without looking through the viewfinder, light enters the viewfinder's eyepiece, affecting exposure metering. Turn the eyepiece shutter open/close dial to close the eyepiece shutter.

*When the shutter release mode is set to "C" (continuous advance mode), the self timer mode can be used to take photos at intervals of 3 to 60 seconds while the shutter release button is pressed.

*To cancel the self timer mode, press the mode setting button "A" once. The self timer mode is canceled and the camera is reset to the normal shooting mode.

*When the shutter release mode selector lever is set to "L" (power off), all the settings aside from the selected mode are reset to the default values.

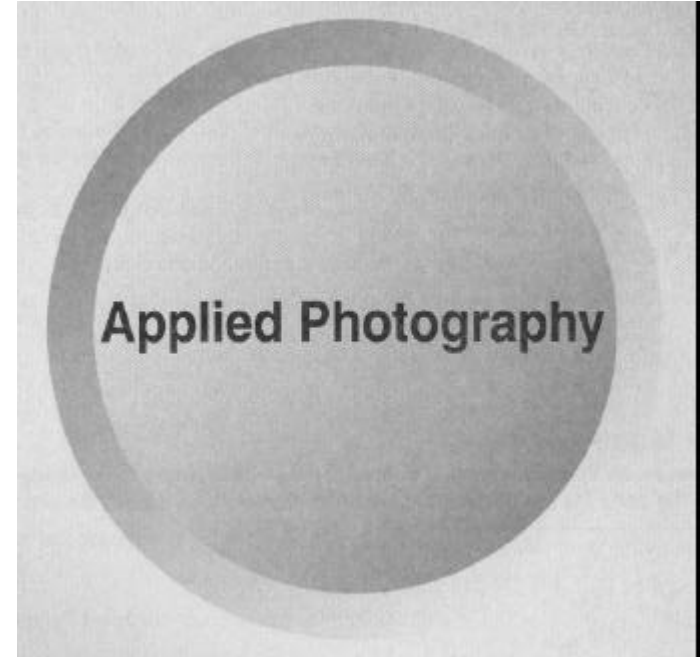

Extended Exposure Modes (Bulb and Time Modes)

To expose the film for extended times (over 30 seconds), set the shutter speed to bulb or set the exposure mode setting dial to "T" (Time Mode).

Bulb Mode

The bulb mode uses electronic control, so the batteries are in constant use during the entire exposure.

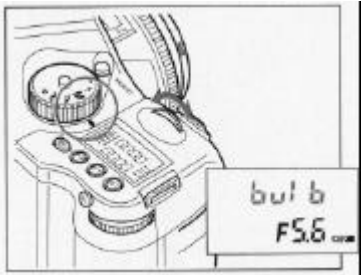

1. Turn the exposure mode setting dial and set it to "M" (manual mode).
2. Turn the front dial counterclockwise to select "bulb", then turn the rear dial to set the aperture.
3. Determine the composition, focus, then take the picture. The shutter remains open as long as the shutter release button is pressed.

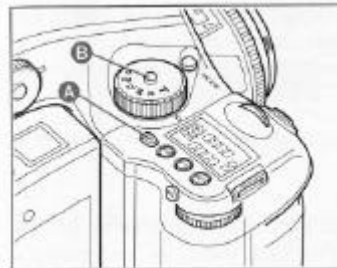

*To prevent the camera from moving, use both an electromagnetic cable release (sold separately) and a tripod.

*When the BL (Backlight) button "A" is pressed, the main LCD panel and the magazine LCD panel light for about 10 seconds. This makes the liquid crystal display panels easier to view in dark places, for example when photographing night views.

*In the "X" exposure mode the lock function is activated. To set a different mode, press the exposure mode dial lock release button "B" while turning the exposure mode setting dial.

Time Mode

The time mode uses mechanical control, so it is best suited for extended exposures. The batteries are not used to keep the shutter open during the exposure.

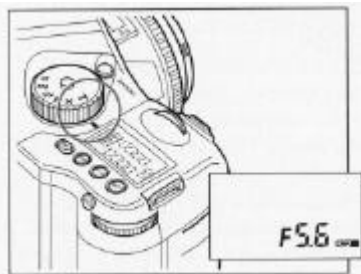

1. Turn the exposure mode setting dial and set it to "T" (time mode).
2. Turn the front or rear dial to set the aperture.
3. Press the shutter release button. Determine the composition, focus, then press the shutter release button. The shutter opens.

4. Once you have achieved the desired exposure, turn the exposure mode setting dial to "X". The time exposure mode is canceled and the shutter closes.

AE Lock Mode

When the AEL button "C" is pressed, the exposure is locked to the value metered at that time. Use this when the object you want to use for exposure metering and the object on which you want to focus are different or when you want to take continuous photographs without changing the exposure.

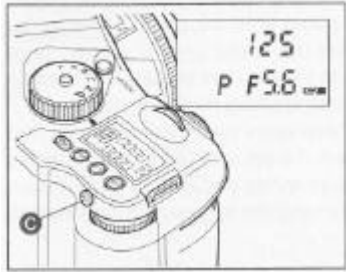

1. Set the shutter release mode selector lever to "S".

2. Turn the exposure mode setting dial and select "P", "Av" or "Tv".

3. Focus on the object you want to use for exposure metering, then with the shutter release button half-pressed Press the AEL button "C" once on the rear of the grip. [] appears on the viewfinder's liquid crystal display panel, indicating that the exposure is locked.



4. With the shutter release button still half-pressed, aim the camera to achieve the desired composition, then release the shutter.

***When the shutter release mode is set to "S" (single-frame advance mode), the AE lock mode is canceled when the shutter release button is pressed. If you wish to take a series of photos using the AE lock function, switch the shutter release mode to "C" (continuous advance mode).**

***To cancel the AE lock mode before taking a photo, press the AEL button "C" again.**

***The focus is locked in "S" mode when the shutter release button is half-pressed.**

***When the AEL button "C" is pressed in, the difference between the metered exposure and exposure with the new composition is displayed in the viewfinder's LCD panel.**

***The AE lock mode is canceled 5 seconds after the AEL button "C" was pressed.**

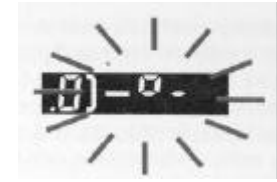
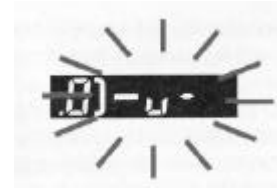

***If the difference between the set value and the metered value exceeds 6EV, "-u-" (under) or "-o-" (over) flashes on the viewfinder's liquid crystal display**

NOTE:

After setting the AE lock mode, the front or rear dial can be used to change the aperture and shutter speed without changing the exposure set with the AE lock function.

When the exposure mode is set to "P" (program AE), turning one of the dials shifts the program between PH and PL. When the exposure mode is set to "Av" (aperture priority AE) or "Tv" (shutter priority AE), turning one of the dials changes the shutter speed or aperture changes, respectively.

Use of the exposure compensation dial during AE lock will change the shutter speed in Av Mode and the aperture in Tv Mode. In the "P" Modes, exposure compensation during AE lock will affect aperture and/or shutter speed, dependant upon the conditions and the program shift mode selected. In all three situations, the exposure compensation will be displayed to the left of the exposure settings in the viewfinder's LCD panel.

How to meter and focus at two different distances

1. First point the camera at the object you want to use for exposure metering, half-press the shutter release button, then press and hold in the AEL button "C".

2. Point the camera to achieve the desired composition, half-press the shutter release button again to refocus, then release the shutter.

Taking Photos with the Mirror Up

Use this when you want to avoid even the slightest shocks, for example when taking photos with a slow shutter speed using a tripod, with a telescopic lens, for close-ups, reproductions, etc.

Neither the auto focus mechanism nor the exposure metering mechanism function when the mirror is raised. Set the focus and exposure compensation before raising the mirror. To prevent the camera from moving, use both an electromagnetic cable release (sold separately) and a tripod. Instructions for use of electromagnetic cable release on page 80.

Using auto focus and auto exposure

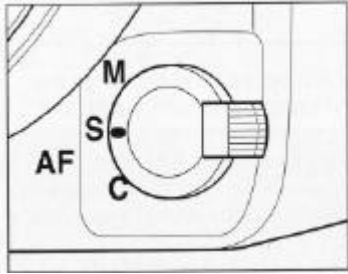

1. Turn the focus mode selector lever and set it to "S".

2. Turn the exposure mode setting dial and set it to "P", "Av" or "Tv".

Look through the viewfinder, determine the focus, composition and exposure, then half-press the shutter release button. (Use the electromagnetic cable release (sold separately) or cable release to maintain the half-pressed status.)



3. Press the AEL button.

When the AEL button is pressed, the AE lock mark [] appears in the viewfinder's LCD panel. Turn the body's mirror up lever towards "M.UP" until it stops to raise the mirror.

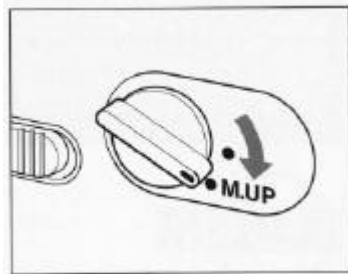

4. Press the shutter release button to take the photo.

*After taking a photograph with the mirror up, when the shutter release button is pressed "-no-RE" flashes on the main LCD panel and the shutter is locked.

*To cancel the AE lock mode, press the AEL button again.

*Leaving the mirror up for long periods of time can result in film fogging. After taking a photograph with the mirror up, be sure to set the mirror up lever back to its original position.

*As a safety precaution, the mirror up lever does not work when no lens is mounted on the body.

*The lens cannot be removed when the mirror is up.

In the manual mode

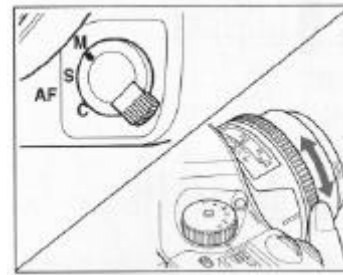

1. Turn the focus mode selector lever, select "M", then turn the lens focusing ring to focus.

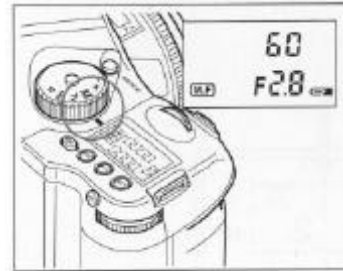

2. Set the exposure mode setting dial to "M", then use the front and rear dials to set the measured shutter speed and aperture.

3. Turn the body's mirror up lever towards "M.UP" until it stops to raise the mirror, then press the shutter release button to take the photo.

•If the lens is pointed at the sun with the mirror turned up and left like this, the sunlight entering from the lens may focus on the shutter blades and damage them. In this situation, put the mirror up right before the moment of exposure and return the mirror to the down position directly after the exposure.

Depth of field

Depth of field (D.O.F) is defined as the zone of sharpness before and behind the plane of focus. It depends on camera subject/distance, focal length of lens, aperture setting and distance the lens is focused at.

In addition to visual observation via the depth of field preview button (See page 66.), the D.O.F can be determined by using the depth of field scale on each lens. f/stop numbers appear on both the right and left side of the white index mark in the center of the scale. Simply read the figures which appear above the f/stop numbers on the distance scale of the lens. (see illustration below)

When the aperture is large
(the subject depth is small)

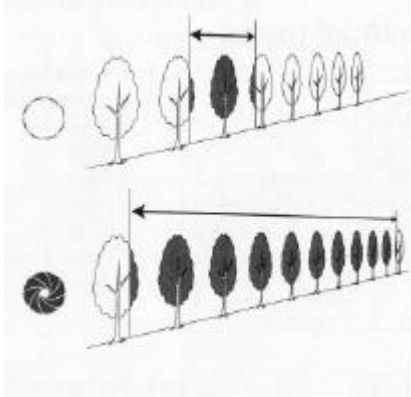

When the aperture is small
(the subject depth is large)

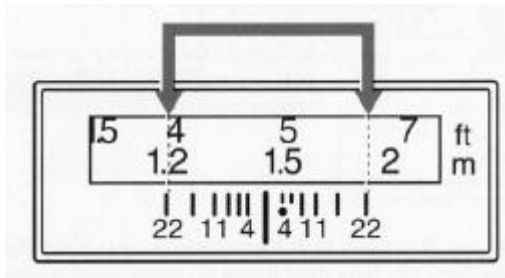

Infrared Photography

When taking photos using infrared film, the position at which the subject is in focus is slightly different from during normal photography. This is because the infrared rays have a longer wavelength and the image converges further back than normal. Use the procedure described below when taking photos using infrared film.

1. Set the focus as usual. Find the point on the distance scale matching the subject depth scale's central index.
2. Set the focus mode selector lever to "M" (manual focus mode). Turn the focusing ring clockwise and set the distance scale to the above infrared index.

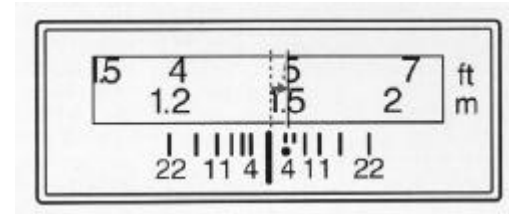

- *Use a red filter when taking photos using infrared film.
- *Be sure to read the infrared film's usage instructions.

Flash Photography

In addition to its standard flash sync system, the Mamiya 645 AF features TTL (through the lens), off the film (OTF), electronic flash exposure automation. A flash sensor located inside the camera body reads the flash reflected off the film surface at the moment of exposure. The sensor is connected via the Mamiya 645 AF's dedicated hot-shoe to a shoe- or handle-mount style Metz flash unit via the Metz SCA 3951 TTL Adapter. Maximum flash sync speed is 1/125 sec., making daytime synchronization possible.

The ISO of the flash is automatically set through the TTL connection from the camera's Film Magazine; any adjustment to this is instantly recognized after the setting is locked and the shutter release is half-pressed. Also, when Film Magazines with different ISO settings are switched on the camera body, the TTL flash connection instantly recognizes the change. To utilize the TTL flash feature with all TTL-operable Metz flash units, a Metz SCA 3951 Module is required. Please see chart below for compatibility and/or additional adapters that may be necessary.

Metz Flash Unit	Adapter	Type of Flash	SCA 3951 Module	SCA 3000C Converter	SCA 3807A Connecting Cable
Metz 32 MZ-3 and -2		Shoe-mount	x		
Metz 40 MZ-3i and -li		Shoe-mount	x		
Metz 45 CL-3 and -4		Handle-mount	x	x	
Metz 50 MZ-5		Handle-mount	x		
Metz 60 CT-4		Handle-mount	x	x	

* Necessary for off-camera and flash bracket use.

The resulting flash exposure automation determines correct flash exposure and automatically adjusts the output of the flash. It also automatically corrects for exposure compensation normally required when using filters, close-up bellows or extension tubes. However as

with all TTL systems, it requires manual compensation for differences in film surface reflection characteristics. The amount of compensation is determined by experimentation and is performed on the Mamiya 645 AF's Film Magazine ISO setting.

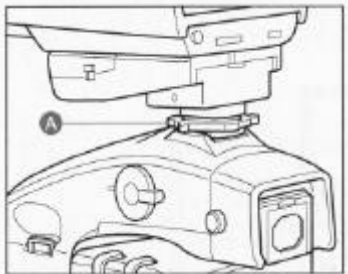

1. Mount the SCA3951 adapter onto the Metz flash, insert fully into the camera's hot shoe, then tighten with the fixing knob "A"
2. Set the exposure mode, then check the shutter speed and aperture.

Exposure mode	Shutter speed	Aperture
P Program AE	Automatically set by camera at 1/125 sec. or less	Automatically set by camera
Av Aperture priority AE	Automatically set by camera at 1/125 sec. or less	Any aperture
Tv Shutter priority AE	1/125 to 30 sec. (Be sure to set at 1/125 sec. or slower)	Automatically set by camera
M Manual mode	1/125 to 30 sec. - bulb (Be sure to set at 1/125 sec. or slower)	Any aperture
X Synchro mode	1/125 sec.	Any aperture

***With TTL flash photography, the reflection of the flash is metered and the intensity of the flash is adjusted automatically, so TTL flash photography is not necessarily suited to all conditions. In the cases described below, we recommend that you use a flash meter to check the intensity of the flash or to use a manual flash setting.**

For example:

- (1) When the size of the subject you want to light with the flash is relatively small within the picture
- (2) When the background behind the subject is extremely bright or when there is a strongly reflective object in the background
- (3) When the background behind the subject is extremely dark (outdoors at night, etc.)
- (4) For flash photography with a narrow latitude film

Metz Flash SCA3951 System Functions

Charging completed indicator in viewfinder	When charging of the flash is completed, a charging completed mark lights on the viewfinder's liquid crystal display panel.
Automatic setting of flash synchronizing speed	When the exposure mode is set to "Av" (aperture priority AE) or "P" (program AE), the shutter speed is set to 1/125 sec. or less when charging of the flash is completed.
Automatic viewfinder (functions when the flash mode is set to the TTL mode/external auto mode)	The flash charge mark $\frac{1}{2}$ flashes after the shutter is released to indicate that the flash was emitted properly.
Auto zoom control	The power zoom reflector is linked to the lens focal length. (Excluding the 32Z-2)
Emission of AF supplemental light	When the focus mode is set to "S", the supplemental light is emitted automatically when the brightness is low. (Excluding the 32Z-2)
Display of flash range (distance)	Displayed on the flash's liquid crystal display panel. (Excluding the 32MZ-3 and 32Z-2)
Others	The film sensitivity data, exposure compensation data and aperture data is sent from the camera to the flash.

***The shutter cannot be released if the flash's OK lamp is lit.**

***When using an SCA300 system flash (Metz 60CT-4, 45CL-4, etc.), also use the SCA3000C converter (sold separately).**

***For details, refer to the operating instructions of the flash and the adapter.**

***To use the guide number indicated on the flash fully, emit the flash several seconds after the charging completed indicator lights.**

***Cautions on using instant film**

Instant film (Polaroid 100-600 series and Fuji FP series), has a lower reflection rate than regular film. Exposure compensation is necessary when using the flash in the TTL mode.

In general, set the exposure compensation to about 1 or 1 1/3 EV on the minus side.

Depth of Field Preview/Eyepiece Shutter

Flash Photography with Flashes other than Metz Flashes

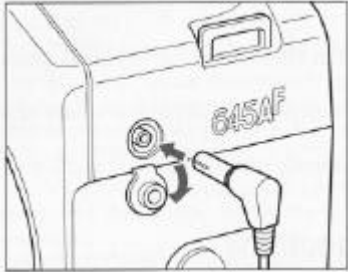

1. Mount the flash onto a flash bracket or if it is a handle-mount style flash attach to the bottom of the camera.

Do not attach a dedicated flash unit to the camera's hot shoe that is not designed specifically for the Mamiya 645AF. To use this type of flash, use a flash bracket or other means, and connect the synchro cord to the camera's synchro terminal.

(See note below about flashes designed exclusively for other camera makes.)

***Remove the rubber cover when connecting the synchro cord.**

After shooting, be sure to attach the rubber cover in order to protect the synchro terminal's contacts.

2. Turn the exposure mode setting dial and set it to "X" (1/125 sec.) or "M" (manual). When "M" (manual) is selected, turn the front dial and set the shutter speed to 1/125 sec. or less.
3. Turn the rear dial to set the aperture, then take the picture.

***This camera's synchro contact is an X contact.**

***When using MF or M grade flash bulbs, set the shutter speed to 1/30 sec. or less for MF grade flash bulbs, 1/15 sec. or less for M grade flash bulbs.**

WARNING

- Using flashes designed exclusively for other makes of cameras may damage the camera's internal mechanisms if connected to the camera's hotshoe. In this situation, use an off-camera flash bracket and connect a PC cord to the camera's synchro terminal.
- *When using flashes with a flash duration of 1/500 sec. or longer, set the shutter speed to 1/30 sec. or less.**

Depth of Field Preview Button

When the preview button is pressed in, the depth of field for the aperture set on the camera can be checked by looking through the viewfinder.

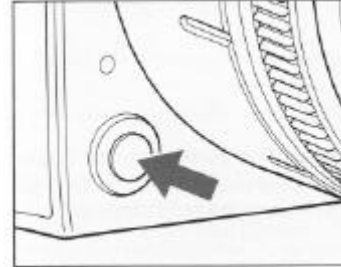

After focusing, press in the preview button.

When using auto focus, the aperture is set to the displayed aperture while the button is pressed and the focus is locked.

Eyepiece Shutter

Use this when there is a strong light source behind the camera or when pressing the shutter release button without looking through the viewfinder. (This prevents exposure error due to light entering from the viewfinder.)

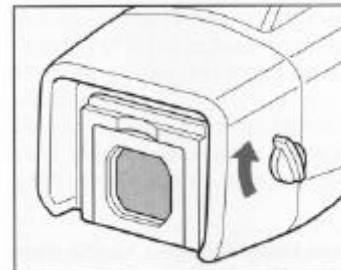

Turn the eyepiece shutter lever in the direction of the arrow.

Changing The Focusing Screen

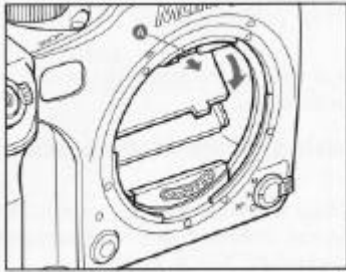

1. Remove the lens.
2. Slide the Focusing Screen Release lever "A" forward, as illustrated, to the left with the tweezers to let be Focusing Screen down.

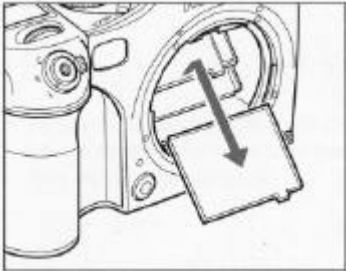

3. Remove the Focusing Screen from the Focusing Screen Frame by grasping the tab on the edge of the screen with tweezers as illustrated.

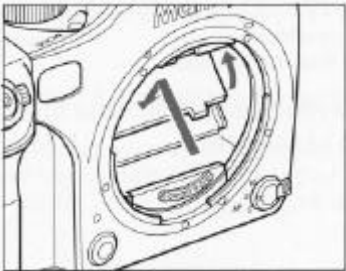

4. In case of attaching, insert your desired Focusing Screen to the Focusing Screen Frame properly and then raise the frame until it clicks.

Caution

- *Since the Focusing Screens' surfaces are soft and easily damaged, handle them carefully.
- *Never touch the surface with bare fingers. Should dust settle on it, merely blow away by using a blower.
- *If the Focusing Screen needs cleaning, send it to the nearest authorized Mamiya service center. Do not attempt to clean the surface of the Focusing Screen, as it is very delicate.

Using the M645 Manual Focus Lenses

When using the M645 manual focus lenses, mount the exclusive viewfinder screen #314474 (sold separately) and set the focus mode to "M" (manual) to enable shooting with stop down metering.

1. Mount the M645 lens to the body, set the focus, then set the lens' A/M lever to "M". Focus confirmation is given in the viewfinder's LCD panel.
2. Select the exposure mode and set the desired lens aperture. (See chart below).
3. Half-press the shutter release button. The shutter speed is displayed.

	Focus mode			Exposure metering mode			Exposure mode				
	Auto focus	Focus aid	Manual	A	S	A-S	P	Av	Tv	M	X
M645 lens	-	○	○	-	○	-	-	○	-	○	○

- = not an available function
○ = available function

*With the M645 lens, adjust the exposure by using stop down metering in the Av exposure mode. The proper exposure cannot be achieved in the "P" (program AE) or "Tv" (shutter priority AE) exposure mode.

*When the M645 lens is mounted, the exposure metering mode is automatically set to "S" (spot exposure metering).

*Focusing using the focus mark is possible when the lens brightness is F5.6 or brighter.

★Note that when the lens' A/M lever is set to "M" after the focus mark ● lights and the aperture is stopped down beyond f/5.6, the defocus direction marks ► and ◀ flash. This is normal, and requires no adjustments.

External Power Supply

When using an external battery case for cold weather operation (sold separately), connect it to the external power socket.

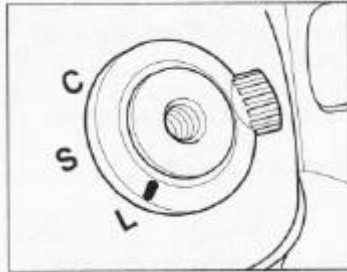

1. Set the shutter mode selector lever to "L".

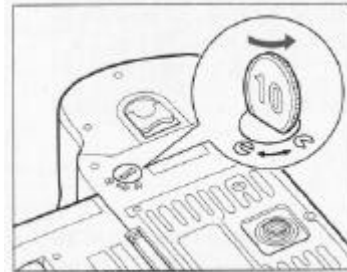

2. Remove the cap.
Use a coin, etc., to remove the external power socket's cap.

3. Remove the batteries from the camera's battery case.
Turn the battery case detach lever, remove the battery case, remove the batteries, then re-insert the battery case into the body and lock the battery case lever again.

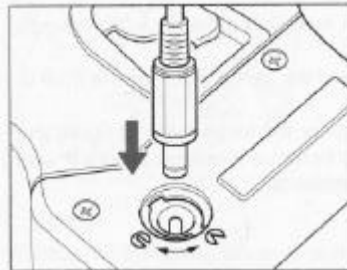

4. Connect the power cord from the external battery case to the external power socket.

***Be sure to attach the battery case to the body.**

***The camera will operate even if the batteries are not removed from the battery case, but remove them for the safety of the camera's body.**

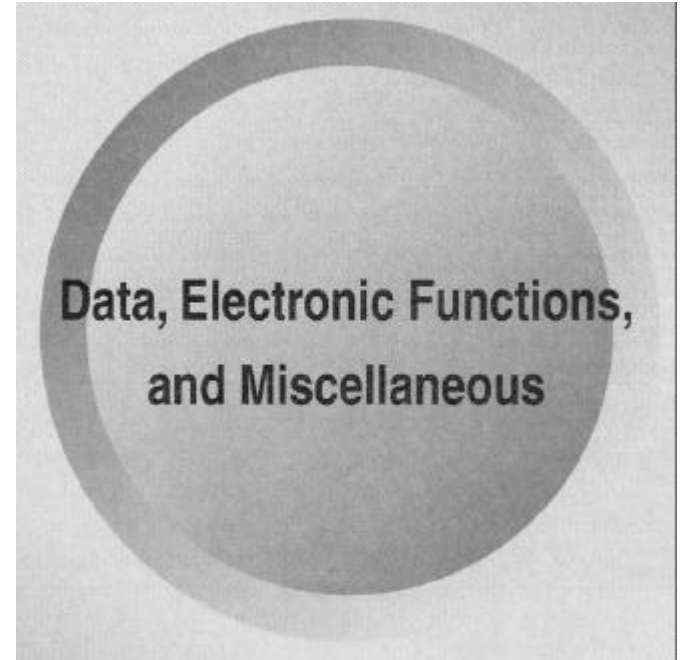

Electronic Dial Operations

	Position	Front dial	Rear dial
Exposure mode	P	Program shifting (P _H ⇄ P ⇄ P _L)	
	Av	Aperture adjustment	
	Tv	Shutter speed adjustment	
	M	Shutter speed adjustment	Aperture adjustment
	X	Aperture adjustment	
	T	Aperture adjustment	
Mode setting button	Auto bracketing	Exposure offset (1/3 to 1 EV)	
	Multiple exposure	No. additional exposures (1 to 5)	
	Self timer	Self timer operating time (3 to 60 sec.)	
F1 key	When Func displayed	Func ⇄ Fd ⇄ dLoc	
	When Func selected	DATA ⇄ DAY ⇄ DF	
	When Fd selected	On ⇄ DF	
	When dLoc selected	On ⇄ DF	
F2 key	When SEt 1 displayed	SEt 1 ⇄ SEt 2	
	SEt 1 selected DAY YEAR	Place shift	Numeric adjustment
	SEt 2 displayed	SEt 1 ⇄ SEt 2	
	SEt 2 selected YEAR	Place shift	Numeric adjustment

Front/Rear Dial Lock Mechanisms (select "dLoc")

When the Electronic Dial Lock is "On", all currently set values in "Av" (Aperture Priority AE), "Tv" (Shutter Priority AE) and "M" (Manual mode) cannot be adjusted with the front or rear dials. This prevents accidental adjustment of shutter speed or aperture values.

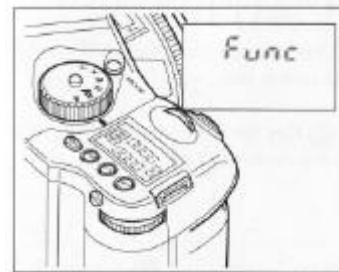

1. Set the shutter release mode selector lever to "S" (to turn the power on).

2. Press the **F1** Key for about 2 seconds. "Func" appears on the external liquid crystal display panel.

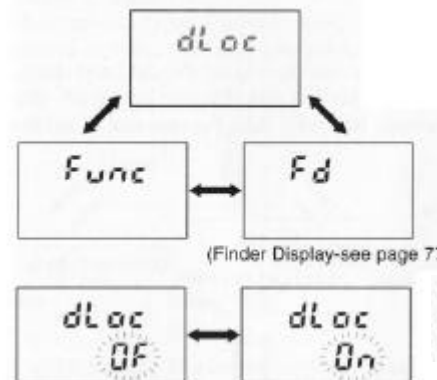

3. Turn the front or rear dial and select "dLoc".

4. Press the **F1** Key again. "DF" or "On" flashes. Turn the front or rear dial to select "On".

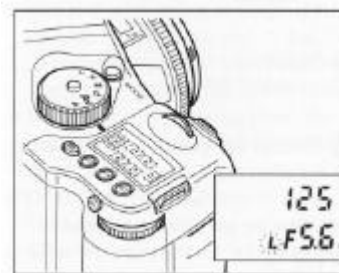

5. Press the **SET** Button for about 2 seconds to register the setting. When the dial lock is turned on, "L" is displayed on the external liquid crystal display panel.

*When a dial is turned while the electronic dial lock is on, L flashes for 3 seconds as a warning.

Turning the electronic dial lock off

★ Perform steps 1 to 4 above, turn the front or rear dial to select "DF", then press the **SET** Button for about 2 seconds.

Superimposing Data (the data is superimposed on the film outside of the image area)

This function allows you to superimpose exposure or date information on the film outside the image area. When selected, the superimposing mode is displayed on the main LCD.

Setting the Date and Time (select "SEt 1")

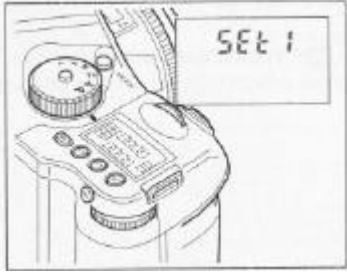

1. Set the shutter release mode selector lever to "S" (to turn the power on).
2. Press the "F2" Key for about 2 seconds. "SEt 1" appears on the main LCD panel.

3. Press the "F2" Key again, then use the front and rear dials to set the date and time. When the front dial is turned clockwise, the position switches between the month, day, year, hours and minutes (the selected position flashes). Turn the rear dial to set the value.

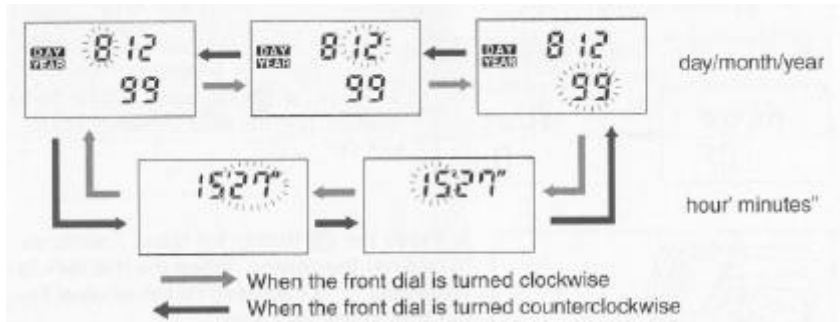

4. After setting the date and time, press the "SET" Button for about 2 seconds to register the setting.

*Check the date and time after replacing the batteries or using an external power supply, and adjust as necessary.

Setting the Index Number (select "SEt 2")

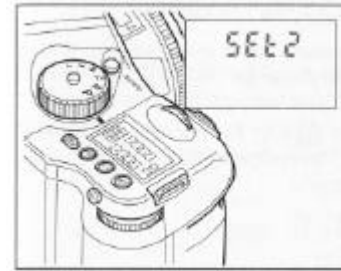

1. Set the shutter release mode selector lever to "S" (to turn the power on).
2. Press the "F2" Key for about 2 seconds, then turn the front or rear dial to display "SEt 2" on the main LCD panel.

3. Press the "F2" Key again, then use the front and rear dials to set the desired index number (3 digits).

When the front dial is turned clockwise, the position switches between the first digit, second digit and third digit (the selected position flashes). Turn the rear dial to set the value.

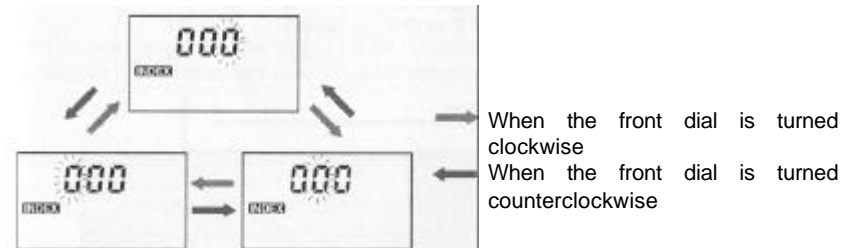

4. After setting the index number, press the "SET" Button for about 2 seconds to register the setting.

*The index number is displayed as a 3-digit number. Data on the number of photos taken is stored in the camera, so the numbers of the photos continue to increment when the magazine is removed and replaced with a different magazine. This function is convenient for managing large amounts of film.

*The starting index number can be set at will. For example, when shooting in different places or for different purposes, you can classify the photos by changing the starting number any of the digits.

*Once the total number of photos taken reaches 999, counting starts over from 001. 000 can also be set using the index number setting procedure.

*After 60 seconds or when another priority button is pressed, the index number setting mode is canceled and the setting is not registered in memory.

* Custom settings remain in the memory even when the shutter release mode selector lever is set to "L" (turning the power off).

Selecting the Data to be Superimposed (select "Func")

There are two data modes which will superimpose information onto the film. If you do not desire to superimpose any information, this function may also be switched off.



1. Set the shutter release mode selector lever to "S" (to turn the power on).

2. Press the "F1" Key for about 2 seconds to display "Func" on the main LCD panel, then press the "F1" Key again.

3. Use the front and rear dials to select the data to be superimposed (**DATA** or **DAY**). The mode of data to be superimposed changes when the front or rear dial is turned clockwise.

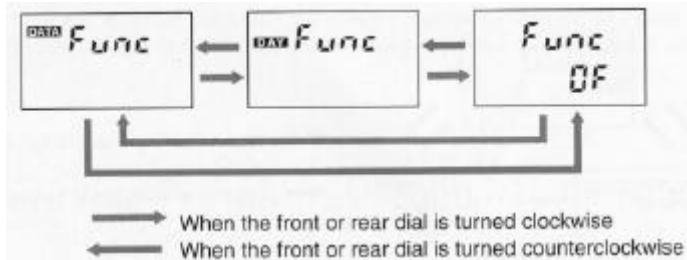

Data superimpose modes

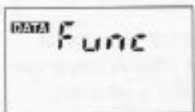

DATA:

The exposure mode, aperture, shutter speed, exposure compensation value, exposure metering mode and index number are superimposed.

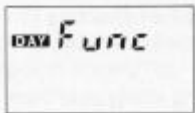

DAY:

The date (year, month and day), time and index number are superimposed.

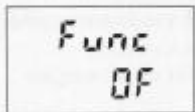

OFF:

The data superimpose function is turned off.

4. Display the desired data superimpose mode on the external liquid crystal display panel, **then press the "SET" Button for about 2 seconds.** The setting is registered and the desired data superimpose mode is displayed on the main LCD panel.

Checking the data to be superimposed

The data to be superimposed switches in the following order each time the "SET" Button is pressed:

Date (year, month and day) - Time - Index number

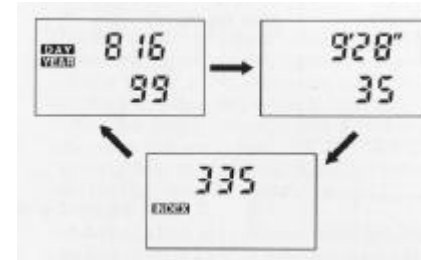

*The display on the main LCD panel returns to normal when the shutter release button is half-pressed or when another priority button is pressed.

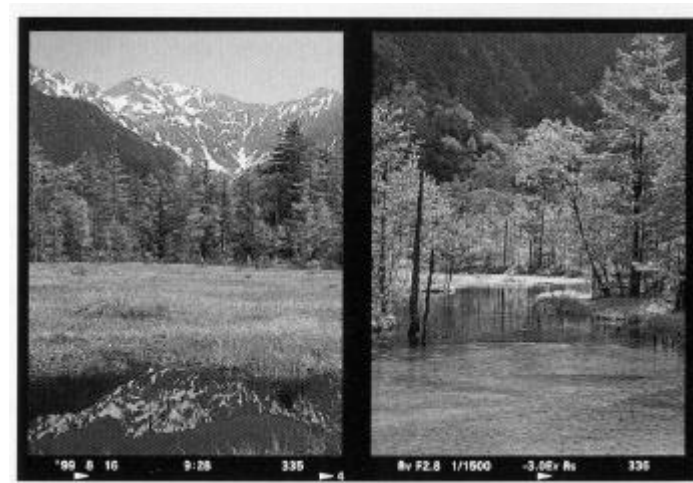

This illustration is for explanatory purposes. The actual display may differ.

Changing the Viewfinder Display in the Manual Mode "M" (select "Fd")

When the exposure mode setting dial is set to "M", it is possible to display only the focus marks and flash charge mark in the viewfinder's LCD panel. This is useful when exposure settings will not change, and this information in the viewfinder could be otherwise distracting.

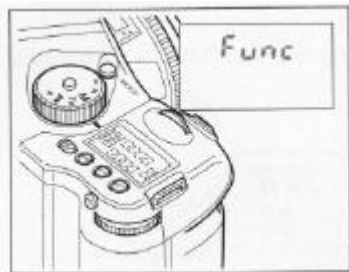

1. Set the shutter release mode selector lever to "S" (to turn the power on).

2. Press the "F1" Key for about 2 seconds to display "Func" on the external liquid crystal display panel.

3. Turn the front or rear dial to select "Fd".

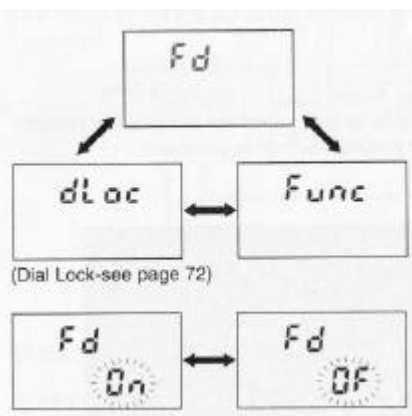

4. Press the "F1" Key again to display "OF" or "On" (flashing). Turn the front or rear dial to select "OF".

5. Press the Button for about 2 seconds to register the setting.

Only the focus marks (▶, ● and ◀) and the flash charge mark (indicating that flash charging is completed) are displayed on the viewfinder's liquid crystal display panel.

Returning to the normal display

*Repeat steps 1 to 4 about, turn the front or rear dial to select "On", then press the "SET" Button for 2 seconds.

Error Messages

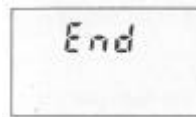

This is displayed for 3 seconds when the end of the film is reached while shooting in the "C" (continuous advance) shutter release mode.

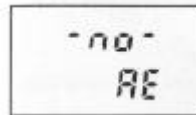

This is displayed when the shutter release button is pressed while the mirror is up when the exposure mode is set to "P" (program AE), "Av" (aperture priority AE) or "Tv" (shutter priority AE).

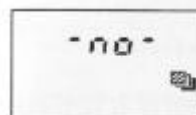

This is displayed when auto bracketing does not function, as follows:

- When the shutter release button is pressed while the exposure mode is set to "M", "X" or "T", this is displayed, the shutter is not released and the auto bracketing mode is canceled.
- When the shutter release button is pressed while shooting with the exposure mode set to "Av", "Tv" or "P" and there are fewer than three frames of film left, this is displayed, the shutter is not released and the auto bracketing mode is canceled.

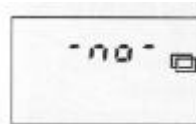

If the magazine is removed while the multiple exposure mode is set, this is displayed and the multiple exposure mode is canceled after the magazine is replaced on the camera.

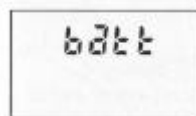

This is displayed when the batteries are discharged and the camera cannot operate. Please replace batteries with a fresh set.

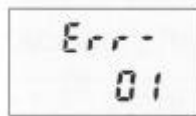

These are displayed when a problem is detected during shooting.

If the error display is not canceled when the shutter release button is pressed again, insert the Dark slide, half-press the shutter release button while pressing the roll film holder's manual film advance button to wind up the film, then contact your nearest Mamiya agent or service center.

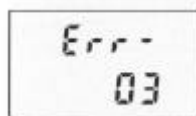
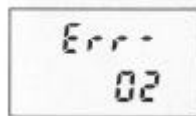

If the shutter cannot be released

- The shutter cannot be released when the batteries are discharged or no batteries are loaded.
- The shutter cannot be released while the film is being advanced.
- The shutter cannot be released while the flash is charging (while the flash mark is flashing) when the shutter release mode is set to "C" (continuous shooting) with a Metz flash mounted with the SCA 3951 adapter. The shutter can be released once flash charging is completed.
- The shutter cannot be released when the magazine is not mounted.
- The shutter cannot be released while the ISO sensitivity is being set after mounting the magazine.
- The shutter cannot be released when the magazine is mounted and the dark slide is inserted.
- The shutter cannot be released when the magazine is mounted and the rear lid is closed with the film wound up.
- When the mode setting button is pressed while the self timer is operating, the self timer is canceled and the shutter will not be released.
- When the exposure mode setting dial is turned while the self timer is operating, the self timer is canceled and the shutter will not be released.
- When the shutter release mode selector lever is operated while the self timer is operating, the self timer is canceled and the shutter will not be released.
- When the focus mode selector lever is operated while the self timer is operating, the self timer is canceled and the shutter will not be released.
- When the exposure mode selector lever is operated while the self timer is operating, the self timer is canceled and the shutter will not be released.
- The shutter cannot be released when one of the error messages is displayed.
- When the shutter release mode selector lever is set to "L" during long exposures of over 1 second, the shutter closes and the long exposure mode is canceled.

Strap/Using a Tripod/Auxiliary Release Contact

Strap

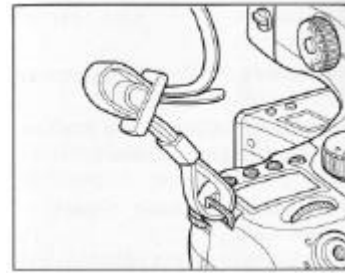

Put the neck strap through the camera's strap mount as shown on the diagram and tighten it. For safety, check that the strap is securely fastened to the strap mount.

Using a Tripod

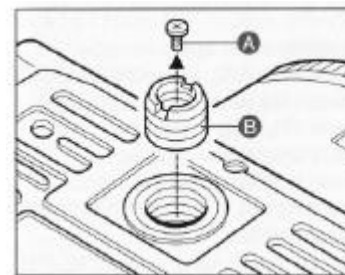

When using a tripod with 3/8 inch screw thread (instead of 1/4 inch screw thread) remove the small screw "A" from the tripod screw hole on the bottom of the body using a Phillips screwdriver, then use a coin to remove the tripod screw adapter bushing "B".

Auxiliary Release Contact

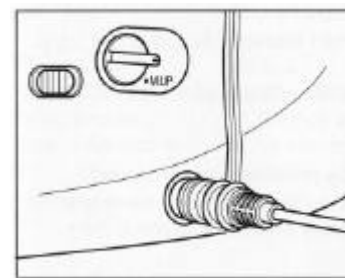

This is the Port for connecting a Mamiya electromagnetic cable release (sold separately) when taking photos with the mirror up, with long exposures or with slow shutter speeds.

#804821 1m (3')
#8048225m (15')

Specifications of 645AF

Camera Type	: 6x4.5cm format, electronically controlled focal-plane shutter, TTL multiple mode AE, AF single lens reflex	Shutter	: Electronically controlled vertical metal focal-plane shutter. (vertical travel)
Actual Image Size	: 56x41.5 mm	Shutter speed	: AE 30 to 1/4000 sec. (1/8 step), manual 30 to 1/4000 sec. (1/2 step), X, B (Bulb, electronically controlled), T (time, mechanically controlled), emergency shutter curtain open mechanism (open when magazine is removed, automatically closed when magazine is attached)
Film Type	: 120 roll film (16 exposures); 220 roll film (32 exposures); Polaroid Land Pack Film (requires special HP402 magazine)	Auto-Bracketing	: Enabled with Mode button, 1/3, 1/2, 2/3, 1-step units
Lens Mount	: Mamiya 645 AF Mount, compatible with M645 Mount (manual focus confirmation, focus aid, stopped-down exposure metering)	Flash Synchronization	: 1/125 sec., automatically sets to 1/125 at faster speeds, synchronized to displayed speed at slower speeds (when Metz flash unit is used)
Viewfinder	: Fixed prism viewfinder magnification x0.71; built-in diopter adjustment (-2.5 to +0.5, separate diopter correction lenses provide adjustment ranges of -5 to -2 diopter and 0 to +3 diopter); built-in eye-piece shutter	Flash control	: TTL direct metering, supports Metz SCA3000 system (SCA3951 Adapter)
Focusing Screen	: Interchangeable between Matte (standard) and Checker and Microprism Type C for Non-AF M645 lenses.	Film transport	: Automatic via built-in motor, single or continuous exposures
Field of View	: 94%* of actual image	Film loading	: Automatic advance to first frame when shutter release button is pressed once (Easy Loading)
Viewfinder Information	: Focus mark, out-of-focus direction mark, aperture value, shutter speed, metering mode (A, S, A/S), exposure compensation value (difference between set value and actual value) and flash ready / OK lamp with TTL Metz connection.	Multiple Exposure	: Enabled with Mode button (1 to 5 exposures); can be cancelled
AF sub-beam	: activates automatically under low light, low contrast. Range: 9m, Automatic switching to flash unit's built-in sub-beam when Metz flash unit is attached.	Main LCD panel	: On camera body; shows aperture value, shutter speed value, self-timer, BL (Backlight), battery check, multiple exposure, programmed AE or programmed AE shift value, data imprinting Interchangeable Film Magazine: ISO speed, type of film (120/220), exposure number
AF Lock	: Half-press on shutter release in S Mode	Data Imprinting	: 7 segment dot matrix; DATA mode: exposure mode, aperture value, shutter speed value, exposure compensation, metering mode, ID number; DAY mode; year, month, date, time, ID number Switchable between enabled and disabled
Exposure Control Modes	: Aperture-priority AE, shutter-priority AE, programmed AE (PH, PL setting possible)	Sync terminal	: X contact (sync speed 1/125 sec.)
Metering method	: Center-weighted average (AV), spot (S) and variable ratio (1.5-step A-S auto change by program shift setting), manual	Cable release socket	: On shutter button
Setting Steps	: Shutter speed and aperture both can be set in half-stop increments; electronic dial lock	Remote-control terminal:	: On side of body; electromagnetic cable release
Light Metering	: TTL metering; center-weighted average (AV), spot (SP), and auto A-S variable ratio	Self-Timer	: 3 to 60 sec. (standard: 10 sec., can be set in 1 sec. steps between 3 and 10 sec., and in 10 sec. steps between 10 and 60 sec.)
Metering Range	: EV 2 to EV 19 (with ISO 100 film, f/2.8 lens)	Depth-of-field confirmation	: Preview Button on body
Exposure compensation	: ±3 EV (1/3 step)	Tripod Socket	: U 1/4 inch and U 3/8 included
Film speed	: ISO 25 to 6400	Power Requirements	: 6 AA-size batteries (alkaline-magnesium, lithium)
AE lock	: With AEL button; released by pressing twice or shutter operation; light metering value differentiation in viewfinder exposure compensation display when ELS button is held down; ±6EV (1/3 step)	Size	: 153(W)X128(H)X184(D)mm
		Weight	: 1,730g(w/o battery)

* This information is based on a linear (horizontal/vertical) measurement.
Specifications and features are subject to change without notice.

Common Sense Camera Care and Practice

The Mamiya 645 AF is a precision optical/mechanical instrument, built for heavy professional use and a long service life, if properly treated and maintained. Please observe these basic caveats:

- Read instructions before using camera.
- Protect camera against shocks and falls. Use the neck strap supplied with it, whenever possible.
- Check the battery frequently and always carry spares. The sealed battery supplied with the camera may have been subject to storage conditions which have reduced its service life.
- Be sure to wipe battery contacts before installation and watch correct polarity.
- Battery life differs, depending on frequency of use, type, age, storage condition, ambient temperature (use External Battery Case in very cold weather), etc.
- Always remove the battery (and film) when camera is not used for a period of time.
- Always keep covers on lenses and camera body.
- Do not store the camera at temperatures exceeding 40°C (105°F) and -10°C (15°F). Also avoid humid or sea air environment.
- Prolonged disuse shortens camera life. Periodically exercise the shutter (at different speeds, lens diaphragms and focusing mounts).
- Protect camera against rain and moisture.
- Do not touch lens surfaces. Use blower or lens tissue to remove dust particles.
- Always test your equipment before going on important assignments.

The Importance of Proper Maintenance

Your camera has mechanisms like film transport, shutter and diaphragm blades etc. They are controlled by gears, levers, springs, and so on. All require special lubrication from time to time. Ambient conditions can also affect these mechanisms, as well as the electronic components and the optical glass of your lenses. We therefore suggest that you have your camera and lenses checked, and if necessary serviced, periodically.

Batteries Care

1. The sealed, new battery which is supplied with this camera may have been subject to storage conditions which have reduced its service life. Therefore it is desirable to replace it with a fresh battery as soon as possible.
2. Carefully wipe the battery contacts before inserting into the chamber. Failure to do so may result in poor electrical contact and consequent malfunctioning of the camera.
3. Always remove battery when camera is not used for a while. Always carry spare batteries.
4. Battery life differs, depending on type, age, storage condition, ambient temperature, frequency of use etc.
5. Be sure to match the poles of the battery with those shown in the diagram in the chamber.
6. Always keep batteries out of the reach of children and never throw used batteries into a fire or expose to excessive heat.
7. When going on trips be sure to carry spare batteries to ensure that the camera will function. Also, as batteries tend to temporarily malfunction at temperatures below freezing, when photographing in extremely cold climates, carry the External Battery Case.
8. When you carry spare batteries, leave them in the original factory packaging. If they are "unpacked", be sure to wrap them carefully in order to prevent them touching each other or any metal objects which can cause them to short circuit and become useless.

After-Sale Servicing

*Be sure to read the terms and conditions in the warranty card.

1. For inquiries, opinions or questions concerning the product, please contact your nearest Mamiya agent or service center.
2. Servicing after the expiration of the period specified in the warranty card (one year after the date of purchase) will be charged to the user. The freight and transport costs should always be paid by the user.
3. The servicing parts for use in repair of the product will be retained at the factory for ten years from the date of discontinuation of production.

O The servicing is available for the same period as the servicing part retention period. As the product may be serviceable even after this period, please consult your dealer or nearest Mamiya service center for the serviceability.

*Servicing of malfunction or damage due to dropping, impact, fire, flood, etc.

- 1) The degree of such a malfunction or damage will be judged by the Mamiya service department.
- 2) Such a malfunction or damage will be classified either non-serviceable or serviceable. When the product is classified to be serviceable, it will be repaired at the expense of the user, even if the malfunction or damage occurred within the warranty period.

Liquid Crystal Display

All displays on the liquid crystal display consist of "8" and the number of places is limited. For this reason, some letters and words are abbreviated.

SEt	→	SET
Func	→	Function
batt	→	Battery
End	→	END
dlac	→	Dial Lock
Fd	→	Finder Display
Err	→	Error
OFF	→	OFF
On	→	On
+	→	+