

SONY®

Cyber-shot

Digital Still Camera

Cyber-shot Handbook

DSC-T2

Before operating the unit, please read this Handbook thoroughly together with the “*Instruction Manual*” and the “*Cyber-shot Step-up Guide*”, and retain them for future reference.

▼CLICK!



Table of contents



Basic Operations



Using the shooting functions



Using the viewing functions



Customizing the settings



Viewing images on a TV



Using your computer



Printing still images



Troubleshooting



Others



Index

Notes on using the camera

Notes on the types of “Memory Stick” that can be used (not supplied)

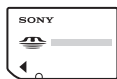

“Memory Stick Duo”:
you can use a “Memory Stick Duo” with your camera.



“Memory Stick”:
you cannot use a “Memory Stick” with your camera.

Other memory cards cannot be used.

- For details on “Memory Stick Duo”, see page 121.

When using a “Memory Stick Duo” with “Memory Stick” compatible equipment

You can use the “Memory Stick Duo” by inserting it into the Memory Stick Duo Adaptor (not supplied).



Memory Stick Duo Adaptor

Notes on the battery pack

- Charge the battery pack (supplied) before using the camera for the first time.
- You can charge the battery pack even if it is not completely discharged. In addition, even if the battery pack is not fully charged, you can use the partially charged capacity of the battery pack as is.
- If you do not intend to use the battery pack for a long time, use up the existing charge and remove it from your camera, then store it in a cool, dry place. This is to maintain the battery pack functions.
- For details on the usable battery pack, see page 123.

Carl Zeiss lens

The camera is equipped with a Carl Zeiss lens which is capable of reproducing sharp images with excellent contrast.

The lens for the camera has been produced under a quality assurance system certified by Carl Zeiss in accordance with the quality standards of Carl Zeiss in Germany.

Notes on the LCD screen and lens

- The LCD screen is manufactured using extremely high-precision technology so over 99.99% of the pixels are operational for effective use. However, some tiny black and/or bright dots (white, red, blue or green) may appear on the LCD screen. These dots are a normal result of the manufacturing process, and do not affect the recording.

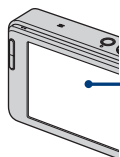

Black, white, red, blue or green points

- If water droplets or other liquids splash on the LCD screen and make it wet, immediately wipe off the screen with a soft cloth. Leaving liquids on the LCD screen surface can harm the quality and cause a malfunction.
- Exposing the LCD screen or the lens to direct sunlight for long periods may cause malfunctions. Be careful when placing the camera near a window or outdoors.
- Do not press against the LCD screen. The screen may be discolored and that may cause a malfunction.
- Images may trail across on the LCD screen in a cold location. This is not a malfunction.
- Be careful not to bump the lens, and be careful not to apply force to it.

The images used in this Handbook

The images used as examples in this Handbook are reproduced images, and are not actual images shot using the camera.

Table of contents

Notes on using the camera	2
Features of the camera	7
Storing – Storing images in the internal memory.....	7
Shooting – Automatic image management	8
Viewing – Viewing images in various ways	8
Sharing – Sharemark function	9
Basic techniques for better images	10
Focus – Focusing on a subject successfully.....	10
Exposure – Adjusting the light intensity	12
Color – On the effects of lighting.....	13
Quality – On “image quality” and “image size”	14
Flash – On using the flash	16
Identifying parts	17
Indicators on the screen	18
Operate the touch panel.....	23
Changing the screen display	24

Basic Operations

Shooting images easily	26
Setting Image size/Self-timer/Flash mode/Macro recording	28
Setting Focus/Metering Mode/ISO/EV	30
Viewing images	35
Selecting how to play back images	36
Using the SCRAPBOOK	39
Deleting images.....	41
Learning the various functions – HOME/Menu.....	43
Menu items.....	46

Using the shooting functions

Switching the shooting mode	47
Shooting images using Scene Selection	48
Shooting menu	51
REC Mode: Selecting the continuous shooting method	
EV: Adjusting the light intensity	
Focus: Changing the focus method	
Metering Mode: Selecting the metering mode	
White Balance: Adjusting the color tones	
Color Mode: Changing the vividness of the image or adding special effects	
Flash Level: Adjusting the amount of flash light	





















Red Eye Reduction: Reducing the red-eye phenomenon

Face Detection: Detecting the face of subject

SteadyShot: Selecting the anti-blur mode

Setup: Selecting the shooting settings

Using the viewing functions

<i>Playing back images from the HOME screen</i>	58
 (Album List): Display the list of image groups	
 (Calendar): Display images on a calendar	
 (Slideshow): Playing back a series of images	
 (Memory Stick): Display images in Memory Stick	
<i>Viewing menu</i>	61
 (Add/Remove Favorites): Adding/Removing Favorites	
 (Add/Remove Sharemark): Adding/Removing the reservation to upload images on the Web	
 (Remove Favorites): Removing Favorites	
 (Remove Sharemark): Removing sharemark to cancel the reservation to upload images on the Web	
 (Retouch): Retouching still images	
 (Paint): Painting on still images	
 (Slideshow): Playing back a series of images	
 (Delete): Deleting images	
 (Protect): Preventing accidental erasure	
 (Album View): Return to Album screen	
 (Print): Printing images using a printer	
 (Rotate): Rotating a still image	
 (Import): Importing images	
 (Export): Exporting images	
 (Select Folder): Selecting the folder for viewing images	
 (Volume Settings): Adjusting the volume	
 (Background): Changing the background	
<i>Painting or putting stamps on still images (Paint)</i>	72

Customizing the settings





<i>Customizing the Manage Memory feature and the Settings</i>	74
 <i>Manage Memory</i>	75
 <i>Memory Tool — Memory Stick Tool</i>	75
Format	Change REC.Folder
Create REC.Folder	Mass Storage

Table of contents

 Memory Tool — Internal Memory Tool	77
Format	
 Settings	78
⚙ Main Settings — Main Settings 1	78
Beep	Initialize
Function Guide	Calibration
⚙ Main Settings — Main Settings 2	80
USB Connect	Video Out
COMPONENT	
📷 Shooting Settings — Shooting Settings 1	81
AF Illuminator	AF Mode
Grid Line	Digital Zoom
📷 Shooting Settings — Shooting Settings 2	83
Auto Orientation	Smile Level
Auto Review	
🕒 Clock Settings	84
🗣 Language Setting	85

Viewing images on a TV

Viewing images on a TV	86
Viewing images by connecting the camera to a TV with the cable for multi-use terminal (not supplied)	86
Viewing an image by connecting the camera to an HD TV	88

Using your computer

Enjoying your Windows computer	90
Installing the software (supplied)	93
On the “Picture Motion Browser” (supplied)	95
Connecting to computers	96
Using the “Music Transfer” (supplied)	99
Viewing “Cyber-shot Step-up Guide”	100

Printing still images

How to print still images	101
Printing images directly using a PictBridge compliant printer	102

Troubleshooting

Troubleshooting	105
Warning indicators and messages	116

Others

Using the camera abroad — Power sources	120
On the “Memory Stick Duo”	121
On the battery pack	123
On the battery charger	124
On “Cyber-shot Station”	125

Index

Index	127
-------------	-----

Features of the camera

Storing images in the internal memory

The camera has approximately 4 GB of internal memory and can store plenty of images. You can load images from computers and play them back on the camera at anytime.

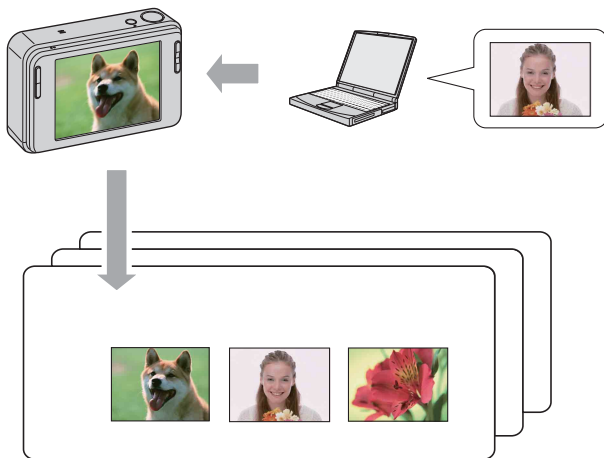

Let's bring images stored in your computer outside with you!

- Use the supplied software "Picture Motion Browser". For details, refer to "Picture Motion Browser Guide".
- Even if "Memory Stick Duo" is inserted in the camera, images will not be saved in "Memory Stick Duo" until the capacity of the internal memory is full. To save images in "Memory Stick Duo", copy (export) the images in the internal memory to "Memory Stick Duo" (page 70).

Shooting *Automatic image management*

This camera automatically classifies images into albums depending on the shooting intervals and frequency.

You can search the images by albums for your convenience.

<Example>

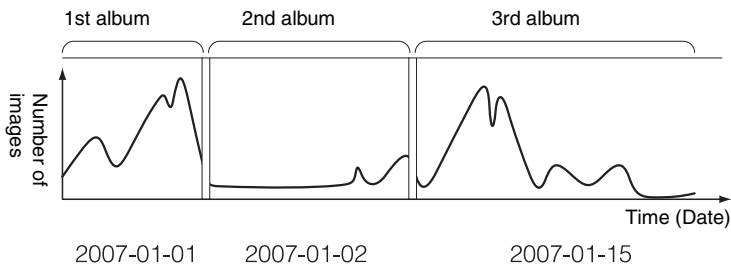

Viewing *Viewing images in various ways*

Favorites

You can choose your favorite images from the album and save them as your favorites (page 61).

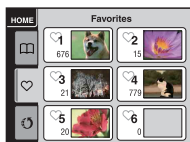

Scrapbook

When you press the SCRAPBOOK button, the images stored in the internal memory will be played back with backgrounds. You can also change backgrounds and enjoy the playback (page 40).

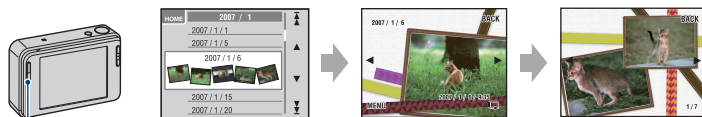

SCRAPBOOK button

Sharing *Sharemark function*

The camera has the application “PMB Portable” embedded within. By saving images stored in the camera as sharemarks, you can easily upload them on the Web using computers. When you connect the camera and a computer with USB cable, “PMB Portable” will automatically start up.

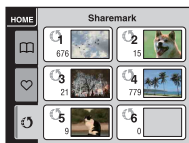
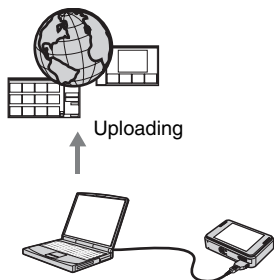

To save images as sharemarks, see page 62.

Basic techniques for better images

Focus

Exposure

Color

Quality

Flash



This section describes the basics so you can enjoy the camera. It tells you how to use various camera functions such as the HOME screen (page 43), the menus (page 45).

Focus

Focusing on a subject successfully

When you press the shutter button halfway down, the camera adjusts the focus automatically (Auto Focus). Remember to press the shutter button only halfway down.

Do not fully press the shutter button straight away.

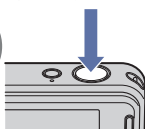

Press the shutter button halfway down.

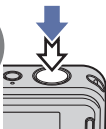

AE/AF lock indicator flashing → lit/beeps



Then press the shutter button fully down.

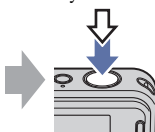

When focusing is difficult → [Focus] (page 31)

If the image looks blurred even after focusing, it may be because of camera shake. → See "Hints for preventing blur" below.

Hints for preventing blur

The camera moved accidentally when you took the image. This is called “Camera shake”. On the other hand, if the subject moved when you took the image, it is called “subject blur”.

Camera shake



Cause

Your hands or body shake while you hold the camera and press the shutter button, and the entire screen is blurred.

What you can do to reduce the blurring

- Use a tripod or place the camera on a flat, stable surface to hold the camera steady.
- Shoot with a 2-second delay self-timer and stabilize your camera by holding your arms firmly at your side after pressing the shutter button.

Subject blur



Cause

Even though the camera is steady, the subject moves during the exposure so the subject looks blurred when the shutter button is pressed.

What you can do to reduce the blurring

- Select **ISO** (High Sensitivity) mode in Scene Selection.
- Select a higher ISO sensitivity to make the shutter speed faster, and press the shutter button before the subject moves.

Notes

- The anti-blur function is enabled in the factory default settings so that the camera shake is reduced automatically. However, this is not effective for subject blur.
- Besides, camera shake and subject blur occur frequently under low-light or slow shutter speed conditions, such as those encountered in 🌙 (Twilight) or 📷 (Twilight Portrait) mode. In that case, shoot with the above tips in mind.

Exposure *Adjusting the light intensity*

You can create various images by adjusting the exposure and the ISO sensitivity. Exposure is the amount of light that the camera will receive when you release the shutter.

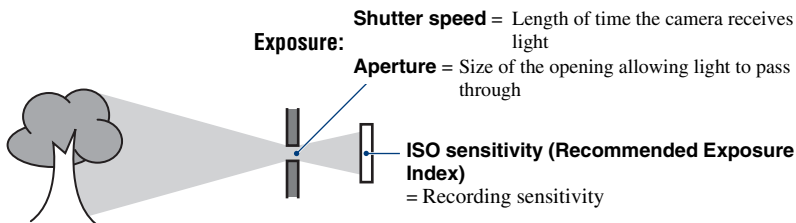

Overexposure
= too much light
Whitish image



Correct exposure



Underexposure
= too little light
Darker image

The exposure is automatically set to the proper value in the auto adjustment mode. However, you can adjust it manually using the functions below.

Adjusting EV:

Allows you to adjust the exposure determined by the camera (pages 25, 34).

Metering Mode:

Allows you to change the part of the subject to be measured to determine the exposure (page 33).

Adjusting ISO Sensitivity (Recommended Exposure Index)

ISO sensitivity is a speed rating for recording media that incorporates an image sensor that receives light. Even when the exposure is the same, images differ depending on the ISO sensitivity.

To adjust the ISO sensitivity, see page 34.



High ISO sensitivity

Records a bright image even in dark locations while increasing shutter speed to reduce blur.

However, the image tends to become noisy.



Low ISO sensitivity

Records a smoother image.





However, when the exposure is insufficient, the image may become darker.

Color

On the effects of lighting

The apparent color of the subject is affected by the lighting conditions.

Example: The color of an image affected by light sources

Weather/lighting	Daylight	Cloudy	Fluorescent	Incandescent
Characteristics of light	White (standard) 	Bluish 	Green-tinged 	Reddish 

The color tones are adjusted automatically in the auto adjustment mode.

However, you can adjust color tones manually with [White Balance] (page 53).

Quality On “image quality” and “image size”

A digital image is made up of a collection of small dots called pixels. If it contains a large number of pixels, the image becomes large, it takes up more memory, and the image is displayed in fine detail. “Image size” is shown by the number of pixels. Although you cannot see the differences on the screen of the camera, the fine detail and data processing time differ when the image is printed or displayed on a computer screen.

Description of the pixels and the image size

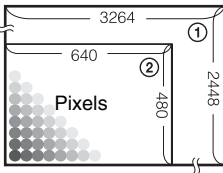

- ① Image size: 8M
 $3264 \text{ pixels} \times 2448 \text{ pixels} = 7,990,272 \text{ pixels}$
- ② Image size: VGA
 $640 \text{ pixels} \times 480 \text{ pixels} = 307,200 \text{ pixels}$











Selecting the image size for use (page 15)

Many pixels (Fine image quality and large file size) → Example: Printing in up to A3 size

Few pixels (Rough image quality but small file size) → Example: An attached image to be sent by e-mail



Basic techniques for better images

The default settings are marked with ✓.

	Image size	Usage guidelines	No. of images	Printing
✓	 8M (3264×2448)	For prints up to A3(11×17")	  More	Fine 
	 3:2*1 (3264×2176)	Shoot in 3:2 aspect ratio		 Rough 
	 5M (2592×1944)	For prints up to A4(8.5×11")		
	 3M (2048×1536)	For prints up to 10×15 cm (4×6") or 13×18 cm(5×7")		
	 VGA (640×480)	Shoot at small image size for e-mail attachments		
	 16:9*2 (1920×1080)	Shoot in HDTV aspect ratio		

*1 Images are recorded in 3:2 aspect ratio, same as photograph printing paper or postcards, etc.

*2 Both edges of the image may be cut off when printing (page 113).

	Movie image size	Frame/Second	Usage guidelines
	 640(Fine) (640×480)	Approx. 30	Shoot high quality movie for display on TV
✓	 640(Standard) (640×480)	Approx. 17	Shoot standard quality movie for display on TV
	 320 (320×240)	Approx. 8	Shoot at small image size for e-mail attachments

• The larger the image size, the higher the image quality.

• The higher the number of frames per second, the smoother the playback image.

Flash *On using the flash*

The eyes of the subject may come out red, or fuzzy white circular spots may appear when using the flash. These phenomena can be reduced by taking the following steps.

The “Red-eye phenomenon”

Pupils become dilated in dark environments. Flash light is reflected off the blood vessels at the back of the eye (retina), causing the “red-eye” phenomenon.

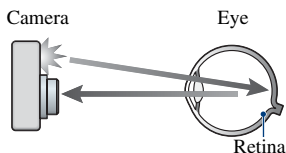

How can the “Red-eye phenomenon” be reduced?

- Set [Red Eye Reduction] to [On] (page 56).
- Select **iSO** (High Sensitivity)* mode in Scene Selection (page 48). (The flash is turned off automatically.)
- When the eyes of the subject turn out red, correct the image with [Retouch] on the viewing menu (page 64) or with the supplied software “Picture Motion Browser”.

The “White circular spots”

This is caused by particles (dust, pollen, etc.) floating close to the lens. When they are accentuated by the camera’s flash, they appear as white circular spots.

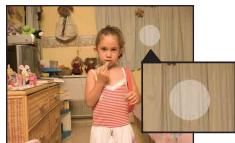
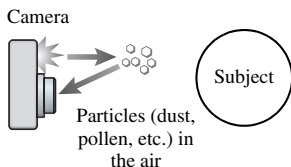

How can the “White circular spots” be reduced?

- Light the room and shoot the subject without a flash.
- Select **iSO** (High Sensitivity)* mode in Scene Selection. (The flash is turned off automatically.)

* Even though you selected **iSO** (High Sensitivity) mode in Scene Selection, the shutter speed might be slower under low-light conditions, or in a dark place. In that case, use a tripod or hold your shooting arms firmly at your side after pressing the shutter button.

Identifying parts

See the pages in parentheses for details of operation.

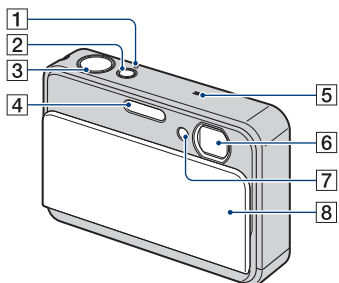

- 1 POWER lamp
- 2 POWER button
- 3 Shutter button (27)
- 4 Flash (29)
- 5 Microphone
- 6 Lens
- 7 Self-timer lamp (28)/Smile shutter lamp (50)/AF illuminator (81)
- 8 Lens cover

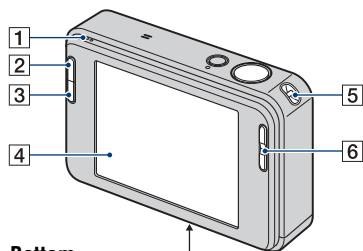

Bottom

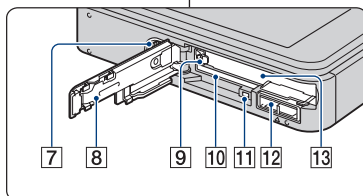

- 1 Speaker
- 2 (Play) button (35)
- 3 SCRAPBOOK button (39)
- 4 LCD screen/Touch panel (23, 24)
- 5 Hook for wrist strap
- 6 T/W (Zoom) button (28)
- 7 Tripod receptacle
 - When a tripod has screws longer than 5.5 mm (7/32 inch), you cannot firmly secure the camera. Forcing the screws to secure may damage the camera.
- 8 Battery/"Memory Stick Duo" cover
- 9 Battery eject lever
- 10 "Memory Stick Duo" slot
- 11 Access lamp
- 12 Multi connector
 - Used in the following situations:
 - Making a USB connection between the camera and the computer.
 - Making a connection to audio/video input jacks on a TV.
 - Making a connection to a PictBridge compliant printer.
- 13 Battery insertion slot

Indicators on the screen

Touch [DISP] on the screen to change to the display selection screen (page 24). See the pages in parentheses for details of operation.

When shooting still images

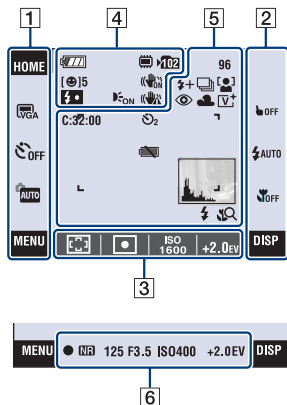

When shooting movies

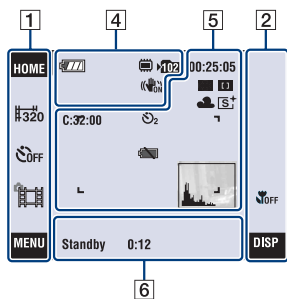

Screen operation

You can change the settings by touching the following: 1, 2, 3.

- Touching an icon displays the guide about the touched item. To hide this guide, touch [?] (page 23).



1

Display	Indication
HOME	Displays the HOME screen.
	Image size settings (15)
	Self-timer settings (28)
	Shooting mode settings (47)
	Shooting mode (Scene Selection) settings (48) <ul style="list-style-type: none"> Touch SCN in the shooting mode settings to select the Scene Selection mode.
MENU	Displays the MENU screen.

2

Display	Indication
BACK	Backs to the previous screen.
	This cancels the focusing on the subject selected by the touch operation.
	Flash mode settings (29)
	Macro/Close focus settings (30)
DISP	Changes the screen display.







3

Display	Indication
 0.5m 1.0m 3.0m 7.0m ∞	AF mode/focus preset settings (31, 32)
	Metering mode settings (33)
ISO 1600	ISO number settings (34)
+2.0EV	Exposure Value settings (34)

Screen indicators











Screen indicators 4 to 6 show the current setting status.

4



Display	Indication
	Battery remaining
[😊]5	Smile shutter (number of still images)
 x1.3 S Q P Q	Zoom scaling (28, 82)
	Flash charging
	SteadyShot (57) <ul style="list-style-type: none"> Displayed when the shutter button is pressed halfway down in the default settings.
	Recording Media (internal memory, “Memory Stick Duo”)
	Recording folder (75) <ul style="list-style-type: none"> This does not appear when using internal memory.
	AF illuminator (81)

Display	Indication
	Vibration warning <ul style="list-style-type: none"> Indicates vibration may prevent you from shooting clear images due to insufficient lighting. Even if the vibration warning appears, you can still shoot images. However, we recommend that you turn on the anti-blur function, using the flash for better lighting or using a tripod or other means to stabilize the camera (page 11).



5

Display	Indication
C:32:00	Self-diagnosis display (116)
	Self-timer (28)
96	Number of recordable images
00:25:05	Recordable time (h:m:s)
	Red-eye reduction (56)
	Flash level (55)
	Recording mode (51)
	Face Detection (56)
	Touch AF indicator (26)
	White balance (53)
	Color mode (54)
	AF range finder frame (31)
	Low battery warning (116)

Indicators on the screen

Display	Indication
	Histogram (24)
	Flash mode (29) <ul style="list-style-type: none"> When [Display Setup] is set to [Image Only], the current settings are displayed.
	Macro/Close focus (30) <ul style="list-style-type: none"> When [Display Setup] is set to [Image Only], the current settings are displayed.

6

Display	Indication
	AE/AF lock (27)
	NR slow shutter <ul style="list-style-type: none"> When the shutter speed becomes slower than a certain speed in low light conditions, the NR (Noise Reduction) slow shutter function is activated automatically to reduce the image noise.
125	Shutter speed
F3.5	Aperture value
ISO400	ISO number (34)
+2.0EV	Exposure Value (34)
Standby REC	Standby a movie/Recording a movie
0:12	Recording time (m:s)

When playing back still images

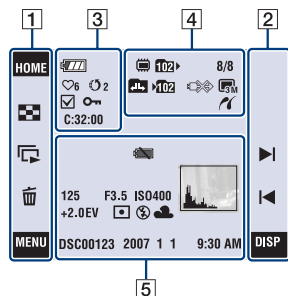

When playing back movies

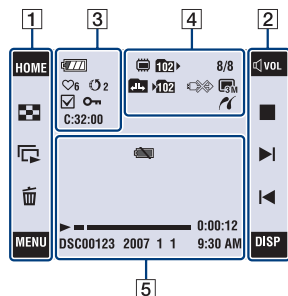

Screen operation

You can change the settings by touching the following: **1**, **2**.

1

Display	Indication
HOME	Displays the HOME screen.
	Changes to index mode.
	Plays back the slide show.
	Deletes the image.
MENU	Displays the MENU screen.
	Selects the playback folder.
	Returns to the single image screen from the index screen.

2

Display	Indication
	Adjusts the volume (35)
	Playback zoom (36)
	Turns ▲/▼/◀/▶ on/off
	Playback
	Stop
	Displays the previous/next image.
DISP	Changes the screen display.









Screen indicators

Screen indicators **3** to **5** show the current setting status.







3

Display	Indication
	Battery remaining
	Favorites
	Sharemark
	Check mark
	Protect (67)
	Playback zoom (36)
C:32:00	Self-diagnosis display (116)

4

Display	Indication
	Playback Media (internal memory, "Memory Stick Duo")
	Playback folder (71) <ul style="list-style-type: none"> This does not appear when using internal memory.
	Image number/Number of images recorded in selected folder
	Changing folder (71) <ul style="list-style-type: none"> This does not appear when using internal memory.
	Recording folder (75) <ul style="list-style-type: none"> This does not appear when using internal memory.
	PictBridge connecting (104) <ul style="list-style-type: none"> Do not disconnect the USB cable while the icon is displayed.
	Image size (15)
	PictBridge connecting (102)

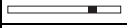
5

Display	Indication
	Low battery warning (116)
125	Shutter speed
F3.5	Aperture value
ISO400	ISO number (34)
+2.0EV	Exposure Value (34)
	Metering mode (33)
	Flash
	White balance (53)
	Playback (35)
	Playback bar
0:00:12	Counter
DSC00123	File number (internal memory)
101-0012	Folder-file number (71) ("Memory Stick Duo")
2007 1 1 9:30 AM	Recorded date/time of the playback image
	Histogram (24) <ul style="list-style-type: none">  appears when histogram display is disabled.

Operate the touch panel

This LCD screen also displays the buttons for operating the camera (touch panel).

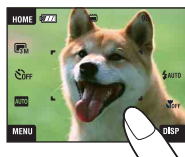
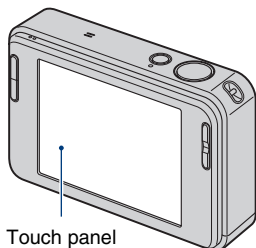

1 Lower the lens cover to turn on the power.
The buttons appear on the screen.

2 Touch the buttons on the screen lightly with your finger.

On the touch panel buttons

- When the item you want to set is not on the screen, touch ▲/▼ to change the page.
- You can return to the previous screen by touching [BACK].
- Touching [?] displays the guide about the touched item. To hide this guide, touch [?] again.

[?]



- To operate the touch panel, press it lightly with your finger or the supplied paint pen.
- Do not press the touch panel with any pointed object other than the supplied paint pen.
- Do not press against the LCD screen more than necessary.
- When the top right of the screen is touched while shooting, the icons will momentarily disappear. Taking your finger off the screen will make the icons reappear.

Changing the screen display

Touch [DISP] on the screen to change to the display selection screen.

- In index mode, you can set the number of images displayed.
- Settings other than [LCD Brightness] can be made separately for shooting and playback.



DISP

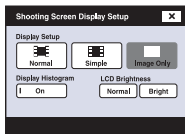

[Display Setup]

This sets if the icons are displayed on the screen.

Normal



Simple



Image Only

- [DISP] is displayed on the screen only when shooting.
- During playback, touch the right or left side of the screen to display the next/previous image, and press the center to display the guide.



[LCD Brightness]

This sets the LCD brightness.

- When viewing images in bright outside light if [LCD Brightness] is set to [Normal], reset to [Bright].
However, the battery power may decrease faster under such condition.

[Display Histogram]

This sets if a histogram is displayed on the screen.

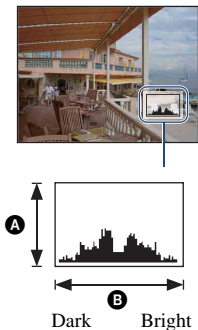

A histogram is a graph showing the brightness of an image. The graph display indicates a bright image when skewed to the right side, and a dark image when skewed to the left side.

- A** Number of pixels
- B** Brightness

- The histogram also appears when playing back a single image, but you cannot adjust the exposure.
- The histogram does not appear in the following situations:
 - While shooting
 - When the menu is displayed.
 - When recording movies
 - During playback
 - When the menu is displayed.
 - In index mode
 - When you are using playback zoom.
 - When you are rotating still images.
 - During playback of movies
 - When you are viewing by Album List.
 - When you are viewing by Favorites list.
 - When you are viewing by Sharemark list.
 - When you are viewing by Calendar.
 - When you are viewing by Scrapbook.
- A large difference in the histogram displayed during shooting and playback may occur when:
 - The flash strobes.
 - The shutter speed is slow or fast.
- The histogram may not appear for images recorded using other cameras.

Shooting images easily

The following steps show you how to shoot images by using basic functions of the camera.

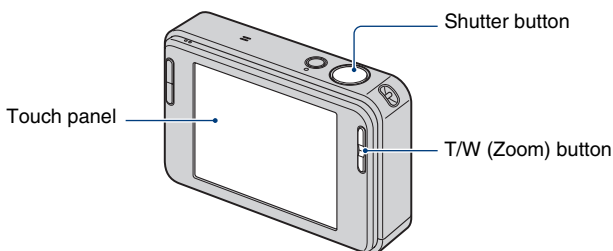

1 Open the lens cover.

2 Hold the camera steady, keeping your arms at your side.

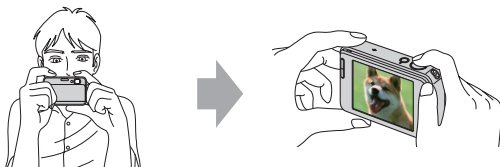

Position the subject in the center of the focus frame or touch the point for focusing.

💡 You can touch the screen to select the point to bring into focus.

Touching the subject on the touch panel displays a frame, and then pressing the shutter button halfway down brings the frame into focus. If there is a face in the frame, in addition to the focus, the brightness and hue are also automatically optimized.

- is displayed if a face is detected in the touched position or is displayed if an object other than a person's face is detected. Touch OFF to cancel this function.
- You cannot use this function when using the digital zoom and Close focus mode.
- This function can be used only in **AUTO** (Auto Adjustment) mode or (Soft Snap) mode.
- If you touch outside the selectable focus range, the selectable range is displayed.



3 Shoot with the shutter button.

- Press and hold the shutter button halfway down to focus.
The ● (AE/AF lock) indicator (green) flashes, a beep sounds, the indicator stops flashing and remains lit.
- Press the shutter button fully down.



AE/AF lock indicator

Shooting movies

Touch [HOME], then touch (Shooting) → (Movie Mode) (page 43).
Or, touch the shooting mode setting icon, then touch (Movie Mode).



Shooting mode setting icon

If you shoot a still image of a subject that is difficult to focus on

- The shortest shooting distance is approx. 50 cm (19 3/4 inches). Shoot in the close-up (Macro) mode or Close focus mode when you shoot a subject closer than the shooting distance (page 30).
- When the camera cannot focus on the subject automatically, the AE/AF lock indicator changes to flash slowly and the beep does not sound. In addition, the AF range finder frame disappears. Recompose the shot and focus again.

Focusing may be difficult in the following situations:

- It is dark and the subject is distant.
- The contrast between the subject and the background is poor.
- The subject is seen through glass.
- The subject is moving quickly.
- There is reflective light or shiny surfaces.
- The subject is backlit or there is a flashing light.

T/W Using the zoom

Press T to zoom, press W to undo the zoom.

- When the zoom scale exceeds 3x, the camera uses the Digital Zoom function.
For details on the [Digital Zoom] settings and the image quality, see page 82.
- The camera zooms slowly while shooting a movie.
- When the Face Detect function is activated, you cannot use the Digital Zoom function.
- While using the Digital Zoom, you cannot focus by touching the screen.

Setting Image size/Self-timer/Flash mode/Macro recording



- ① Changing the image size
- ② Using the self-timer
- ③ Selecting a flash mode for still images
- ④ Shooting close-up

Changing the image size

Touch the image size setting icon on the screen. Touch the desired item, then [BACK].
For details on the image size, see page 14.



Image size setting icon

Using the self-timer

Touch the self-timer setting icon on the screen. Touch the desired item, then [BACK].



Self-timer setting icon

Self-Timer Off (OFF): Not using the self-timer

Self-Timer 10sec (10): Setting the 10-second delay self-timer

Self-Timer 2sec (2): Setting the 2-second delay self-timer

When you press the shutter button, the self-timer lamp flashes and a beep sounds until the shutter operates.

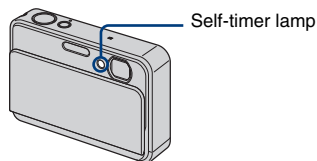

To cancel, touch .

- Use the 2-second delay self-timer to prevent blur of an image. The shutter is released 2 seconds after you press the shutter button, which reduces camera shake when the shutter button is pressed.

Flash (Selecting a flash mode for still images)

Touch the flash mode setting icon on the screen. Touch the desired item, then [BACK].



Flash Auto ( AUTO): Flashes when there is insufficient light or backlight (default setting)

Flash On ()

Slow Synchro (Flash forced on) ( SL): The shutter speed is slow in a dark place to clearly shoot the background that is out of flash light.

Flash Off ()

- The flash strobos twice. The first flash adjusts the light quantity.
- While charging the flash,  is displayed.

Macro/Close focus (Shooting close-up)

Touch the Macro/Close focus mode setting icon on the screen. Touch the desired item, then [BACK].



Macro/Close focus mode setting icon

Macro Off (OFF)

Macro On (M): W side: Approx. 8 cm or farther (3 1/4 inches or farther), T side: Approx. 25 cm or farther (9 7/8 inches or farther)

Close focus enabled (C): Locked to the W side: Approx. 1 to 20 cm (13/32 to 7 7/8 inches)

Macro

- Setting the zoom all the way to the W side is recommended.
- The in-focus range becomes narrow, and the subject may not be entirely in focus.
- The Auto Focus speed drops.

Close focus

- Use this mode to shoot at even closer distances than (Macro On) recording.
- The optical zoom is locked to the W side and cannot be used.
- You cannot shoot images in the Burst or Bracket mode (page 51).
- You cannot use the Face Detection feature when you shoot images in the Close focus mode.
- This mode is cancelled if you turn off the power or switch the mode to another one.

Setting Focus/Metering Mode/ISO/EV

The Focus, Metering Mode, ISO and EV icons appear only when the shooting mode is set to PGM (Program Auto).







- ① Changing the focus method
- ② Selecting the metering mode
- ③ Selecting a luminous sensitivity
- ④ Adjusting the light intensity

Focus: Changing the focus method

You can change the focus method. Use the menu when it is difficult to get the proper focus in auto focus mode.

- When the shooting mode is set to , [Focus] appears in [MENU].

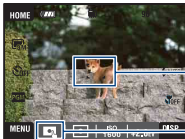
<p>✓  (Multi AF)</p>		<p>Focuses on a subject in all ranges of the finder frame automatically.</p> <ul style="list-style-type: none"> This mode is useful when the subject is not in the center of the frame.  <p>AF range finder frame (Only for still image)</p> <p>AF range finder frame indicator</p>
<p> (Center AF) (Only for still image)</p>		<p>Focuses on a subject in the center of the finder frame automatically.</p> <ul style="list-style-type: none"> By using together the AF lock function, you can compose the image the way you want.  <p>AF range finder frame</p> <p>AF range finder frame indicator</p>
<p> (Spot AF) (Flexible Spot AF) (Only for still image)</p>		<p>By moving the AF range finder frame to wherever you like on the screen, you can focus on an extremely small subject or a narrow area.</p> <ul style="list-style-type: none"> To set the Flexible Spot AF, see page 32. This is useful when you shoot using a tripod and the subject is out of the center area. When shooting a moving subject, take care to hold the camera steady so that the subject does not deviate from the range finder frame.  <p>AF range finder frame</p> <p>AF range finder frame indicator</p>

0.5 m	Focuses on the subject using a previously set distance to the subject. (Focus preset) • Use “Focus preset” when it is difficult to get sharp focus with automatic focusing, such as when shooting a subject through a net or window.
1.0 m	
3.0 m	
7.0 m	
∞ (unlimited distance)	

- AF stands for Auto Focus.
- Allow a margin of error in distance in the setting of “Focus preset”. Setting the zoom to the T side or pointing the lens up or down will increase error.
- When you use Digital Zoom or AF illuminator, the AF range finder frame is disabled and appears in a dotted line. In this case, the camera works to focus on the subjects at the center of the screen.

How to use the [Spot AF]

- ① Set the shooting mode setting icon to **PGM** (Program Auto), then touch [BACK].
- ② Touch the focus mode setting icon →  (Spot AF).
- ③ Touch [BACK] to turn off the menu.



- ④ Touch where you want to focus the shot.







- If you touch outside the selectable focus range, the selectable range is displayed.

Metering Mode: Selecting the metering mode

Selects the metering mode that sets which part of the subject to measure to determine the exposure.

- When the shooting mode is set to , [Metering Mode] appears in [MENU].

✓	 (Multi)	Divides into multiple regions and measures each region. The camera determines a well-balanced exposure (Multi-pattern metering).
	 (Center)	Measures the center of the image, and determines the exposure based on the brightness of the subject there (Center-weighted metering).
	 (Spot) (Only for still image)	<p>Measures only a part of the subject (Spot metering).</p> <ul style="list-style-type: none"> This function is useful when the subject is backlit or when there is strong contrast between the subject and the background. <div data-bbox="412 550 603 695" style="border: 1px solid black; padding: 5px;">  </div> <p style="margin-left: 20px;">Spot metering cross hairs Positions on the subject</p>

- For details on the Exposure, see page 12.
- When using spot metering or center-weighted metering, setting [Focus] to [Center AF] is recommended to focus on the metering position (page 31).

ISO: Selecting a luminous sensitivity



Low ISO sensitivity



High ISO sensitivity

Sets the ISO sensitivity.

✓	ISO AUTO (Auto)	You can reduce image blurring in dark locations or moving subjects by increasing ISO sensitivity (select a larger number). However, images tend to become noisier as the ISO sensitivity number increases. Select an ISO sensitivity number according to shooting conditions.
	ISO 80	
	ISO 100	
	ISO 200	
	ISO 400	
	ISO 800	
	ISO 1600	
	ISO 3200	

- For details on the ISO sensitivity, see page 13.
- You can select only from [ISO AUTO], [ISO 80] to [ISO 400] when set to Burst or Exposure Bracket.
- When shooting under bright conditions, the camera automatically enhances tones to prevent images appearing pale (excluding when [ISO] is set to [ISO 80]).

EV: Adjusting the light intensity

Manually adjusts the exposure.

- When the shooting mode is set to **AUTO**, **SCN** or , [EV] appears in [MENU].

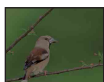

Toward -



Toward +



	-2.0EV	Toward -: Darkens an image.
✓	0EV	The exposure is determined automatically by the camera.
	+2.0EV	Toward +: Brightens an image.

- For details on the Exposure, see page 12.
- The compensation value can be set in 1/3EV increments.
- If you shoot a subject in extremely bright or dark conditions, or when you use the flash, the exposure adjustment may not be effective.

Viewing images

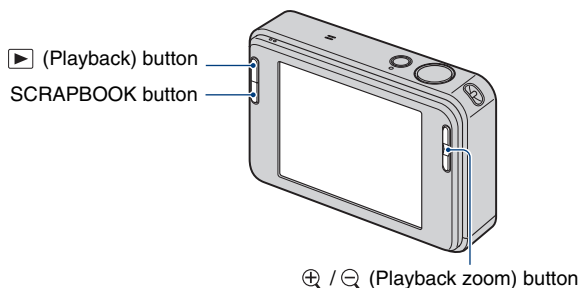

The following steps explain how to view images stored in the internal memory.



To view images in “Memory Stick Duo”, touch  (Memory Stick) in  (View Images) in HOME screen (page 60).

Viewing a single image

1 Press (Playback) button.

- If you press  (Playback) when the camera is powered off, the camera is turned on automatically and set to playback mode. To switch to the shooting mode, press  (Playback) again.

2 Touch (previous)/ (next) to select an image.

Movie:

Touch  to play back a movie.

Rewind/Fast forward: /  (Touch  or  to return to normal playback.)

Volume control: Touch , then adjust the volume with / .

Touch  again. The volume control bar disappears.





Stop: Touch .

- Movies of image size [320] are displayed in a smaller size.

Viewing an enlarged image (playback zoom)

Touch a still image while it is displayed to enlarge the corresponding area.

Touch  to zoom out.

   : Adjusts the position.

BACK: Cancels playback zoom.

: Turns     on/off.

• To store enlarged images, see [Trimming] (page 64).

You can also enlarge the image with the T/W (Zoom) button.

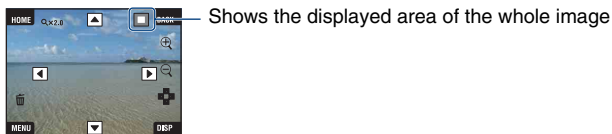

Selecting how to play back images

Images stored in the camera are separated into groups by events and played back as albums. You can change how to play back images in the album to make the images easier to search.

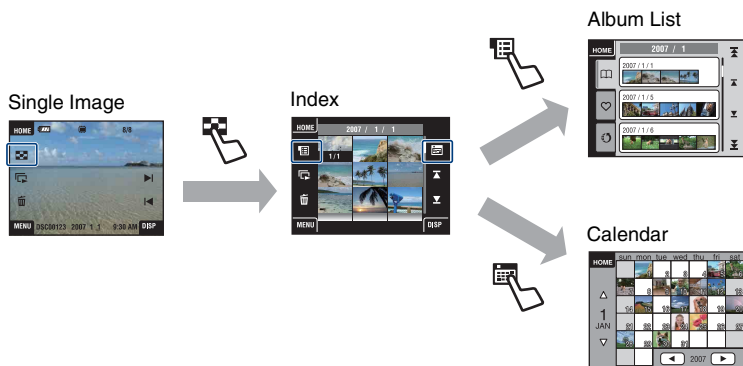

- You can move from the Album List screen to Favorites list or Sharemark list.
- You can name albums by using "Picture Motion Browser". For details, refer to "Picture Motion Browser Guide".

Viewing an index screen

When you touch  (Index) while viewing the image in single image screen, the image will be displayed by each album in index mode.



Touch  to display the previous/next page. To return to the single image screen, touch the thumbnail image.



- If you touch [DISP] in index mode, you can set the number of images displayed in the index screen.
- You can switch the display from index screen to Calendar or Album Lists.

Viewing by Album List

Touch the  (Album List) in the index screen to view images by the album list.

Move on/back the month with  and move on/back the album with .

Touch the album to return to the index screen.

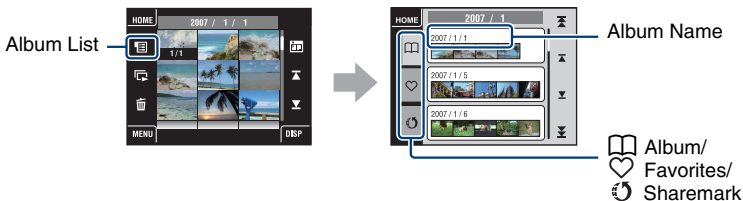

Touch the following icons to switch the image group to display.

 (Favorites) list

You can view images saved as Favorites.

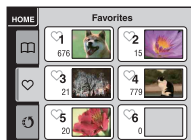

Viewing images

🔖 (Sharemark) list

You can load images saved as sharemarks to computers.

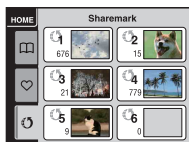





For details on how to make the settings, see pages 61 and 62.

- You can also view the album lists by selecting [Album List] in  (View Images) in HOME screen.

Viewing by Calendar

Touch the  (Calendar) in the index screen to view images by the calendar.

Move on/back the year with /  and move on/back the month with / .

Touch the thumbnail image to return to the index screen of the album, which includes the touched image.

Calendar

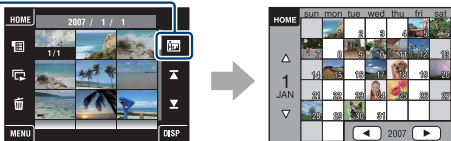

- You can also view the calendar by selecting [Calendar] in  (View Images) in HOME screen.

Using the SCRAPBOOK

When an album is created in the camera, a scrapbook with the images in the album laid out on a background is automatically created. Scrapbooks created in the camera can be only viewed with the camera.

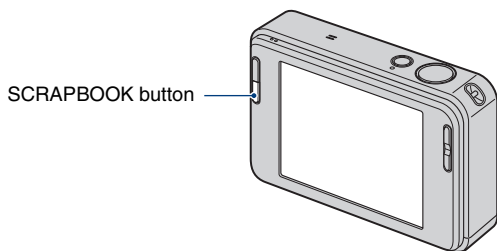

- Images saved in “Memory Stick Duo” cannot be viewed as scrapbooks.

1 Press SCRAPBOOK button.

Scrapbook list is displayed.

- Whether the power of the camera is off, the power will turn on when you press the SCRAPBOOK button, and images will be played back in scrapbook mode.



▲/▼: Move on/back the album list.

⏪/⏩: Move on/back the month.

2 Touch ▲/▼, then touch the album you want to play back.

- Album name and date will be displayed on the cover (1st page) of scrapbook.
- You can change the background of scrapbook in the MENU screen when you select the cover.
- Cover image will not be shown in single image screen even if you touch it.

3 Touch ◀▶ to turn the page.

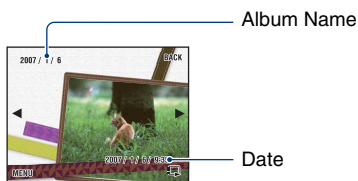

BACK: Return to scrapbook list.

◀▶: Move to the page before or after.

🔄: Turn the page automatically. Touch the image to stop turning the page.

- The camera will automatically decide the position of the image to be displayed.
- Touch the image to view in single image screen.

To change backgrounds

- ① Touch [MENU].
- ② Touch [Background] → [Background].
Screen to change the theme will be displayed.



- ③ Touch ◀▶ to turn the page, and touch the desired background.

Deleting images

▶ (Playback) button

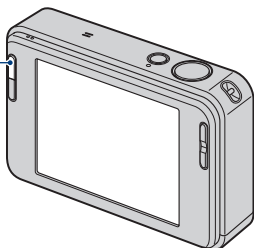





1 Press ▶ (Playback) button.

2 Display the image you want to delete, then touch  (Delete).



3 Touch [OK].

When you delete images from the MENU screen

- ① Touch [MENU] while displaying in single-image mode or in index mode.
- ② Touch  (Delete).
- ③ Touch to select the desired deletion method among  (This Image),  (Multiple Images),  (Whole Album),  (All In This Folder).

When you select [This Image]

You can delete the selected image.

Touch [OK].

When you select [Multiple Images]

You can select and delete multiple images simultaneously.



- ① Touch the center of the image to put a check mark on the image you want to delete. The ✓ mark is checked in the check box of the image. To cancel the deletion, touch the image again to deselect the mark.

Single Image

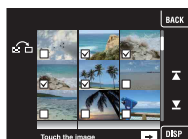

Index Display



- Touching  displays the index screen. At this screen, touch the thumbnail images to add a check mark to the images you want to delete.
 - Touching  at the index screen returns to single-image mode.
- ② Touch , and then touch [OK].

When you select [Whole Album] or [All In This Folder]

You can delete all the images in the selected album or folder. Touch [OK].

Learning the various functions – HOME/Menu

Using the HOME screen

The HOME screen is the gateway screen for all the functions of your camera, and can be called up regardless of the mode setting (shooting/viewing).

1 Touch [HOME] to display the HOME screen.

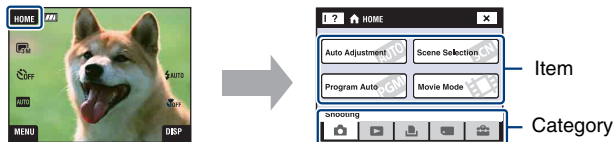





2 Touch the category you want to set.

3 Touch the item in the category you want to set.

- You cannot display the HOME screen when a PictBridge connection or a USB connection is made.
- The camera is set to the shooting mode by pressing the shutter button halfway down.
- Touch [X] or [BACK] to return to the previous screen.

HOME items

Touching [HOME] displays the following items. Details on the items are displayed on the screen by the guide.

Categories	Items
 Shooting	Auto Adjustment (page 47) Scene Selection (page 47) Program Auto (page 47) Movie Mode (page 47)
 View Images	Album List (page 58) Calendar (page 58) Slideshow (page 58) Memory Stick (page 60)
 Printing, Other	Print (page 102) Music Tool (page 99) Download Music Format Music
 Manage Memory	Memory Tool Memory Stick Tool (page 75) Format Create REC. Folder Change REC. Folder Mass Storage Internal Memory Tool (page 77) Format
 Settings	Main Settings Main Settings 1 (page 78) Beep Function Guide Initialize Calibration Main Settings 2 (page 80) USB Connect COMPONENT Video Out
	Shooting Settings Shooting Settings 1 (page 81) AF Illuminator Grid Line AF Mode Digital Zoom Shooting Settings 2 (page 83) Auto Orientation Auto Review Smile Level
	Clock Settings (page 84)
	Language Setting (page 85)

Using the menu items

1 Touch [MENU] to display the MENU screen.

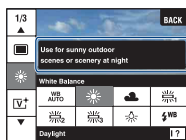

Touch [?] to hide the function guide when shooting (page 23).

- Different items will become visible depending on the selected mode.

2 Touch the desired menu item.

- If the desired item is hidden, keep touching ▲/▼ until the item appears on the screen.

3 Touch the desired setting item.

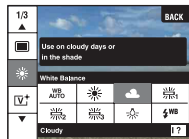

- When **OK** is displayed on the function guide during playback, touch **OK** to confirm.

4 Touch [BACK] to turn off the menu.

Menu items

The menu items available to set by touching [MENU] vary depending on the mode setting (shooting/viewing).

Only items available to set will be displayed on the screen.

(✓ : available)

Selected mode:	Auto Adjustment	Scene Selection	Program Auto	Movie Mode
----------------	-----------------	-----------------	--------------	------------

Shooting menu (page 51)

REC Mode	✓	✓ ^{*2}	✓	—
EV ^{*1}	✓	✓	—	✓
Focus ^{*1}	—	—	—	✓
Metering Mode ^{*1}	—	—	—	✓
White Balance	—	✓ ^{*2}	✓	✓
Color Mode	—	—	✓	✓
Flash Level	—	—	✓	—
Red Eye Reduction	✓	✓ ^{*2}	✓	—
Face Detection	✓	✓ ^{*2}	—	—
SteadyShot	—	✓	✓	✓
Setup	✓	✓	✓	✓

^{*1} These icons will be displayed on the bottom of the screen when the shooting mode is set to **PGM** (Program Auto).

^{*2} The operation is limited according to the selected Scene Selection mode (page 48).

Viewing menu (page 61)

(Add/Remove Favorites)	(Add/Remove Sharemark)
(Remove Favorites)	(Remove Sharemark)
(Retouch)	(Paint)
(Slideshow)	(Delete)
(Protect)	(Album View)
(Print)	(Rotate)
(Import)	(Export)
(Select Folder)	(Volume Settings)
(Background)	



Switching the shooting mode

You can switch the shooting mode on the HOME screen.

Shooting modes:

There are three shooting modes available for still images: Auto Adjustment, Scene Selection, Program Auto; and there is one recording mode for movies. The default setting is Auto Adjustment.

To switch the shooting mode to other than Auto Adjustment, follow the procedure described below.

① Touch [HOME] to display HOME screen.

② Touch (Shooting).

③ Touch the desired mode.

- You can also change the shooting mode by touching the shooting mode setting icon (page 18).



AUTO: Auto Adjustment

Allows you to shoot still images with the setting adjusted automatically.

SCN: Scene Selection

Allows you to shoot with preset settings according to the scene (page 48).

PGM: Program Auto

Allows you to shoot with the exposure adjusted automatically (both the shutter speed and the aperture value). Also you can select various settings using the menu. (For details on the functions available, see page 46.)

M: Movie Mode

Allows you to record movies with audio.

Shooting images using Scene Selection

Scene Selection modes

The following modes are preset to match the scene conditions.



High Sensitivity

Allows you to shoot images without a flash under low light conditions, reducing blur.



Landscape

Focuses only on a distant subject to shoot landscapes, etc.



Hi-Speed Shutter

Allows you to shoot moving subjects outdoors or in other bright places.

- The shutter speed becomes faster, so images shot in dark places become darker.



Smile Shutter

When the camera detects a smile, the shutter is released automatically. For details, see page 50.



Soft Snap

Allows you to shoot images with a softer atmosphere for portraits and flowers, etc.



Twilight Portrait*

Allows you to shoot sharp images of people with the night view in the background without compromising the atmosphere.



Twilight*

Allows you to shoot night scenes at far distance without losing the dark atmosphere of the surroundings.



Beach

Allows you to record the blue of the water clearly when shooting seaside or lakeside scenes.





Snow

Allows you to record clear images preventing sunken colors in snowy scenes or other places where the whole screen appears white.



Fireworks*



















Allows you to record fireworks in all their splendor.

*When you shoot images using  (Twilight Portrait),  (Twilight) or  (Fireworks) mode, the shutter speed is slower and the images tend to blur. To prevent blurring, the use of a tripod is recommended.

Functions you can use in Scene Selection

For shooting an image appropriately according to the scene condition, a combination of functions is determined by the camera. Some functions are not available, depending on the Scene Selection mode.

(✓: you can select the desired setting)

	Macro/ Close Focus	Flash	Face Detection	Burst/ Bracket	EV	White Balance	Red Eye Reduction	SteadyShot
	✓/—		—	—	✓	✓*	—	✓
	✓/—	✓	—	—	✓	—	—	✓
	✓/—	✓	✓	✓	✓	—	✓	✓
	✓/—		—	—	✓	—	✓	✓
	—/—		—	—	✓	—	—	✓
	—/—		—	✓	✓	—	✓	✓
	✓/—		—	✓	✓	—	✓	✓
	✓/—		—	✓	✓	—	✓	✓
	✓/—		—	✓	✓	—	✓	✓
	—/—		—	—	✓	—	—	✓

* [Flash] cannot be selected in [White Balance].

Shooting in Smile Shutter mode

① Press the shutter button all the way down.

The [😊] is displayed to indicate that the camera is at the capturing smile screen. When a smile is detected, the shutter is released automatically. The smile shutter lamp will light after shooting (page 17).

② Holding down the shutter button again exits the capturing smile screen.

- A maximum of six images can be taken. Shooting ends automatically when either the recording medium/internal memory becomes full or six images is reached.
- If a smile is not detected, set the [Smile Level] (page 83).
- A smile cannot be detected unless a face is detected.
- Depending on the shooting environment, faces cannot be detected and the shutter may not function.
- A smile can be detected for only one person displayed in the face detection frame after pressing the shutter button all the way down.
- If multiple faces are detected, the face touched before pressing the shutter button halfway down is given priority. If no face is touched, the camera will select the primary subject for deciding which face is given priority.
- The image may not be in focus if the distance between the camera and the subject is changed after pressing the shutter button all the way down. The suitable exposure may not be obtained if the surrounding brightness changes.
- Depending on the shooting situation, the camera may judge that the face is smiling and make the shutter function, even if the face is not smiling.

💡 Hints for better capturing of smiles

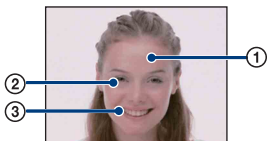



① Do not cover the eyes with the bangs.

② Try to orient the face in front of the camera and be as level as possible. The eyes are easier to detect when narrowed.

③ Give a clear smile with an open mouth. The smile is easier to detect when the teeth are showing.

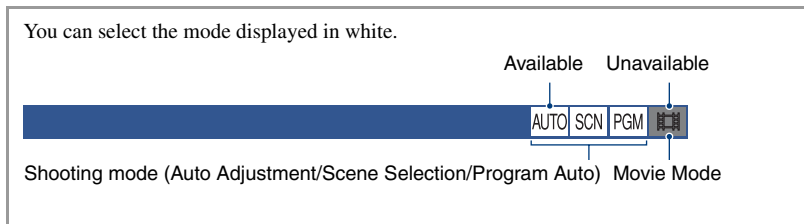
The available modes are indicated as shown below. For details on how to operate the menu, see page 45.









The default settings are marked with .

REC Mode: Selecting the continuous shooting method



Selects whether the camera performs continuous shooting or not when you press the shutter button.

	 (Normal)	Does not shoot continuously.
	 (Burst)	<p>Records up to 100 images in succession when you press and hold down the shutter button.</p>  <ul style="list-style-type: none"> The flash is set to  (Flash Off).
	BRK ±0.3EV	<p>Records a series of three images with the exposure values automatically shifted (Exposure Bracket). The larger the bracket step value, the larger the shift of the exposure value.</p> <ul style="list-style-type: none"> When you cannot decide the correct exposure, shoot in the Exposure Bracket mode, shifting the exposure value. You can select the image with the best exposure afterward.  <ul style="list-style-type: none"> You cannot shoot in the Exposure Bracket mode, when the shooting mode is set to AUTO (Auto Adjustment). The flash is set to  (Flash Off).
	BRK ±0.7EV	
	BRK ±1.0EV	

On the Burst

- When recording with the self timer, a series of a maximum of five images is recorded.
- The recording interval is approx. 0.51 seconds. The recording interval becomes longer, depending on the setting for the image size.
- When the battery level is low, or when the internal memory or “Memory Stick Duo” is full, the Burst stops.
- You may not be able to shoot images in the Burst mode depending on the Scene Selection mode (page 49).

On the Exposure Bracket

- The focus and white balance are adjusted for the first image, and these settings are also used for the other images.
- When you adjust the exposure manually (page 34), the exposure is shifted based on the adjusted brightness.
- The recording interval is approx. 0.51 seconds.
- If the subject is too bright or too dark, you may not be able to shoot properly with the selected bracket step value.
- You may not be able to shoot images in the Exposure Bracket mode depending on the Scene Selection mode (page 49).

EV: Adjusting the light intensity



Manually adjusts the exposure. This menu is the same as the item that you set by touching the EV setting icon in **PGM** mode. See page 34.

Focus: Changing the focus method



You can change the focus method. Use the menu when it is difficult to get the proper focus in auto focus mode. This menu is the same as the item that you set by touching the Focus setting icon in **PGM** mode. See page 31.

Metering Mode: Selecting the metering mode













Selects the metering mode that sets which part of the subject to measure to determine the exposure. This menu is the same as the item that you set by touching the Metering Mode setting icon in **PGM** mode. See page 33.

White Balance: Adjusting the color tones





Adjusts color tones according to the surrounding light conditions. Use this function if image color appears unnatural.

✓	 (Auto)	Adjusts the White Balance automatically.
	 (Daylight)	Adjusts for outdoors conditions on a fine day, evening views, night scenes, neon signs, fireworks, etc. 
	 (Cloudy)	Adjusts for a cloudy sky or a shady location. 
	 (Fluorescent Light 1)/  (Fluorescent Light 2)/  (Fluorescent Light 3)	Fluorescent Light 1: Adjusts for white fluorescent lighting. Fluorescent Light 2: Adjusts for natural white fluorescent lighting. Fluorescent Light 3: Adjusts for day white fluorescent lighting. 
	 (Incandescent)	Adjusts for places under incandescent lamp, or under bright lighting, such as in a photo studio. 







	 WB (Flash) (Only for still image)	Adjusts for the flash conditions. <ul style="list-style-type: none"> You cannot select this item when shooting movies. 
--	--	---

- For details on the white balance, see page 13.
- Under fluorescent lights that flicker, the white balance function may not work correctly even though you select [Fluorescent Light 1], [Fluorescent Light 2] or [Fluorescent Light 3].
- Except in [Flash] mode, [White Balance] is set to [Auto] when you shoot images using the flash.
- Some options are not available depending on the Scene Selection mode (page 49).

Color Mode: Changing the vividness of the image or adding special effects

 AUTO SCN PGM 

You can change the brightness of the image, accompanied by effects.

<input checked="" type="checkbox"/>	 (Normal)	Sets the image to standard color. 
	 (Vivid)	Sets the image to bright and deep color. 
	 (Natural)	Sets the image to quiet color. 



	 (Sepia)	Sets the image to sepia color. 
	 (B & W)	Sets the image to black and white. 

- You can select only [Normal], [Sepia] or [B & W] when shooting movies.

Flash Level: Adjusting the amount of flash light



Adjusts the amount of flash light.

	 (-)	Toward -: Makes the flash level lower.
✓	 (Normal)	
	 (+)	Toward +: Makes the flash level higher.

- To change flash mode, see page 29.



Red Eye Reduction: Reducing the red-eye phenomenon



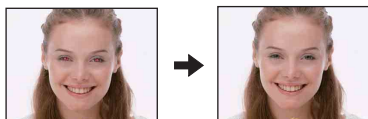



The flash strobos two or more times before shooting to reduce the red-eye phenomenon when using the flash.

<input checked="" type="checkbox"/>	 (Auto)	When the Face Detect function is activated, the flash strobos automatically to reduce the red-eye phenomenon.
<input type="checkbox"/>	 (On)	The flash always strobos to reduce the red-eye phenomenon.
<input type="checkbox"/>	 (Off)	Does not use Red Eye Reduction.



- To avoid blurring of images, hold the camera firmly until the shutter is released. It usually takes a second after you press the shutter button. Be also sure not to allow the subject to move during this period.
- Red-eye reduction may not produce the desired effects. It depends on individual differences and conditions, such as distance to the subject, or if the subject looked away from the pre-strobe. In such a case, you can correct the red-eye using [Retouch] in the viewing menu after shooting (page 64).
- If you do not use the Face Detect function, Red Eye Reduction does not work, even when you select [Auto].
- This setting is not available depending on the Scene Selection mode (page 49).





Face Detection: Detecting the face of subject

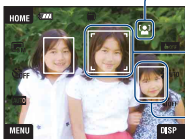



Selects whether to use the Face Detect function continuously or when the touch panel is touched.



<input type="checkbox"/>	 (Continuous)	<p>Detects the faces of your subjects and adjusts the focus, flash, exposure, white balance and red-eye reduction settings automatically.</p>  <p>Touching the face changes the Face Detection frame to the Face Priority frame. If the subject area you touch is not a face, the section near the touched area is brought into focus.</p>
<input checked="" type="checkbox"/>	 (When touched)	Touch the screen, and if a face is detected, operation is the same as [Continuous].





- When the Face Detect function is activated
 - You cannot use the AF illuminator.
 - You cannot use the Digital Zoom function.
- In  (Soft Snap) mode, the default setting is [Continuous].
- In the  (Smile Shutter) mode, the Face Detect function activates continuously.
- Up to 8 faces of your subjects can be detected. However, only up to 4 faces of your subjects can be detected when you shoot images with  (Soft Snap).
- When the camera detects more than one subject, the camera will judge which is the main subject and set focus by priority.
- The frame for which the focus is set will turn green by pressing the shutter button halfway down. All the subjects at equal distance to the focused one are also focused, even if the frames do not turn green.
- Face Detection may fail, depending on the conditions.
- When the shooting mode is a mode other than **AUTO** (Auto Adjustment),  (Smile Shutter) mode, and  (Soft Snap) mode, the Face Detect function is always off.

SteadyShot: Selecting the anti-blur mode

AUTO **SCN** **PGM** 



Selects the anti-blur mode.

<input checked="" type="checkbox"/>  (Shooting)	Activates the anti-blur function when pressing the shutter button halfway down.
 (Continuous)	Always activates the anti-blur function. You can stabilize images even when zooming up a far subject. <ul style="list-style-type: none"> • Battery consumption is faster than in [Shooting] mode.
 (Off)	Does not use anti-blur mode.

- In Auto Adjustment mode, [SteadyShot] is set to  (Shooting).
- For movies, you can set  (Continuous) or  (Off) only. The default setting is set to  (Continuous).
- The anti-blur function may not work properly in the following cases.
 - When camera shake is too strong
 - When the shutter speed is slow, for example, shooting night scenes

Setup: Selecting the shooting settings

AUTO **SCN** **PGM** 

Selects the settings for the shooting function. The items appearing in this menu are same ones as those in  (Shooting Settings) in  (Settings) on the HOME screen. See page 44.



Playing back images from the HOME screen

You can select the ways to playback images.

- ① Touch [HOME].
- ② Touch (View Images).
- ③ Touch the desired viewing method.

(Album List): Display the list of image groups

Separates the images stored in the internal memory in a list.
The images are separated by albums, favorites, or sharemarks.

(Calendar): Display images on a calendar

Separates images stored in the internal memory by the date and displays the thumbnail image on a calendar.

(Slideshow): Playing back a series of images

- ① Touch [Slideshow] on the HOME screen.

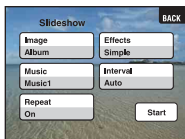

- ② Touch [Start] to start playback.
 - You cannot view images in “Memory Stick Duo” by slide show.

To adjust the volume of the music

Touch the panel to display the volume control screen, and then adjust the volume with \llcorner/\lrcorner .
Or adjust from the (Volume Settings) on the MENU screen, before the playback starts.



- Touch [X] to turn off the volume control screen.

To end the slide show

Touch the panel, and then touch [Exit].

To change the setup

You can change the slide show settings.

- ① Touch [MENU] →  (Slideshow) →  (Slideshow).
 - ② Touch the desired menu item.
 - ③ Touch the desired setting, then touch [Start].
- You can change the settings by touching  on the volume control screen.

The following items can be set.





The default settings are marked with .

Image		
	Album/Favorites/Sharemark	Plays back the images in the selected Album, Favorites or Sharemark.
	All	Plays back all the images in Album, Favorites or Sharemark in order.

Effects		
	Simple	A simple slide show suitable for a wide range of scenes.
	Nostalgic	A moody slide show reproducing the atmosphere of a movie scene.
	Stylish	A stylish slide show proceeding at a middle tempo.
	Active	A high-tempo slide show suitable for active scenes.
	Normal	A basic slide show switching images at a predetermined interval.

- Only still images are displayed when [Simple], [Nostalgic], [Stylish] or [Active] is selected.
- When [Normal] is selected, [Music] is fixed to [Off]. However, you can hear the sound of movies.

Music		
The preset-Music differs depending on the effect you select. The music played is determined by default according to the effect you select. You can custom set any music with any effect as desired.		
	Music1	The default setting for a [Simple] slide show.
	Music2	The default setting for a [Nostalgic] slide show.
	Music3	The default setting for a [Stylish] slide show.
	Music4	The default setting for a [Active] slide show.
	Off	Setting for a [Normal] slide show. No Music available.

Playing back images from the HOME screen

Interval		
<input type="checkbox"/>	3 sec	Sets the display interval of images for a [Normal] slide show.
<input type="checkbox"/>	5 sec	
<input type="checkbox"/>	10 sec	
<input type="checkbox"/>	30 sec	
<input type="checkbox"/>	1 min	
<input checked="" type="checkbox"/>	Auto	The interval is set to suit the selected [Effects] item. The setting is fixed to [Auto] when [Normal] is not selected as the [Effects].

Repeat		
<input checked="" type="checkbox"/>	On	Plays back images in a continuous loop.
<input type="checkbox"/>	Off	After all the images have been played back, the slide show ends.

💡 To add /change Music files

You can transfer a desired music file from your CDs or MP3 files to the camera to play back during Slide show. You can transfer music using [Music Tool] in  (Printing, Other) on the HOME screen and the "Music Transfer" software (supplied) installed on a computer. For details, see page 99.

- You can record up to four pieces of music on the camera (The four preset pieces (Music1 – Music4) can be replaced with the ones you transferred).
- A maximum length of each music file for music play back of the camera is about 3 minutes.
- If you cannot play back a Music file due to damage or other malfunctions to the file, execute [Format Music] (page 99) and transfer the music again.

(Memory Stick): Display images in Memory Stick

Displays the images saved in "Memory Stick Duo" in single image screen or index screen.
When playing back images in HOME screen, the image will first be displayed in index screen.

Single Image



Index Display



- If you touch [DISP] in index mode, you can set the number of images displayed in the index screen.
- To return to the single image screen, touch the thumbnail image.

This section explains the menu items available when you touch [MENU] in playback mode. For details on how to use the menu, see page 45.

You can select the mode displayed in white.

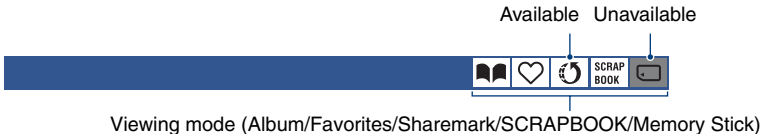







Viewing mode (Album/Favorites/Sharemark/SCRAPBOOK/Memory Stick)

(Add/Remove Favorites): Adding/Removing Favorites



Select your favorite image and add/remove from groups as favorites.







 (This Image)	Add or remove the image you selected as favorites.
 (Multiple Images)	Select multiple images and add or remove them as favorites.
 (Whole Album)	Select all the images in the album and add or remove them as favorites.

- ① Touch [MENU] while the image is displayed in single image screen or index screen.
- ② Touch  (Add/Remove Favorites).
- ③ Touch  (This Image).
The screen to select where to add the image as favorites is displayed.
- ④ Touch the folder of the group you want to add the image as favorites.
- ⑤ Touch , then [OK].



To add multiple images as favorites

- ③ Touch  (Multiple Images).
The screen to select where to add the images as favorites is displayed.
- ④ Touch the folder of the group you want to add the images as favorites.



In single image screen:

- ⑤ Display the desired image to add as favorites with   and touch the center of the image.
The  mark will be displayed on the selected image.
- ⑥ Continue to display the desired image to add as favorites with   and touch the center of the image.
- ⑦ Touch , then [OK].

In index screen:

- ⑤ Touch the thumbnail image of the desired image to add as favorites.
The  mark will be displayed on the selected image.
- ⑥ Repeat step ⑤ if you want to add other images as favorites too.
- ⑦ Touch , then [OK].

To add all images in album as favorites

- ① Touch [MENU] while the image is displayed in index screen.
- ② Touch  (Add/Remove Favorites).
- ③ Touch  (Whole Album).



To remove Favorites



Touch the image you want to remove the Favorites by taking the same steps as in “To add multiple images as favorites”.
The  will disappear.

(Add/Remove Sharemark): Adding/Removing the reservation

to upload images on the Web

You can add/remove the reservation to upload images on the Web (Sharemark).







 (This Image)	The reservation to upload the image selected on the Web will be added/removed.
 (Multiple Images)	The reservation to upload the multiple images selected on the Web will be added/removed.
 (Whole Album)	The reservation to upload all the images in the album on the Web will be added/removed.

- ① Touch [MENU] while the image is displayed in single image screen or index screen.
- ② Touch  (Add/Remove Sharemark).
- ③ Touch  (This Image).
The screen to select where to add the image as sharemark is displayed.
- ④ Touch the folder of the group you want to add the image as sharemark.
- ⑤ Touch , then [OK].



To add the reservation to upload multiple images on the Web

- ③ Touch  (Multiple Images).
The screen to select where to add the images as sharemark is displayed.
- ④ Touch the folder of the group you want to add the images as sharemark.



In single image screen:

- ⑤ Display the desired image to add as sharemark with   and touch the center of the image.
The  mark will be displayed on the selected image.
- ⑥ Continue to display the desired image to add as sharemark with   and touch the center of the image.
- ⑦ Touch , then [OK].

In index screen:

- ⑤ Touch the thumbnail image of the desired image to add as sharemark.
The  mark will be displayed on the selected image.
- ⑥ Repeat step ⑤ if you want to add other images as sharemark too.
- ⑦ Touch , then [OK].

To add all images in album as sharemark

- ① Touch [MENU] while the image is displayed in index screen.
- ② Touch  (Add/Remove Sharemark).
- ③ Touch  (Whole Album).

To remove Sharemark



Touch the image you want to cancel the sharemark by taking the same steps as in “To add the reservation to upload multiple images on the Web”.

The  will disappear.

(Remove Favorites): Removing Favorites





You can remove the images saved as favorites from the favorites list.

 (This Image)	Remove the image you selected from the favorites list.
 (Multiple Images)	Select multiple images and remove them from the favorites list.
 ALL (All In Favorites)	Remove all images within the selected favorites list.

(Remove Sharemark): Removing sharemark to cancel the reservation to upload images on the Web



You can cancel the reservation to upload images on the Web (Sharemark).



 (This Image)	Remove sharemark from the image you selected.
 (Multiple Images)	Select multiple images and remove sharemark.
 ALL (All In Sharemark)	Remove sharemark from all of the images within the selected sharemark list.









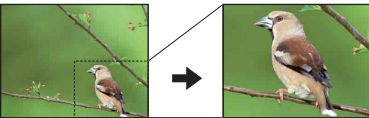

 (Retouch): Retouching still images









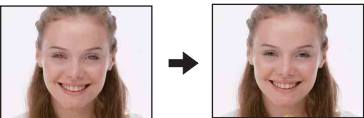

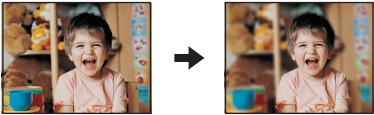









Adds effects or makes corrections to a recorded image and records it as a new file.
The original image is retained.





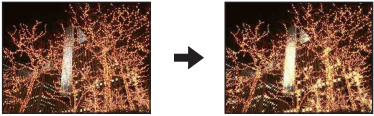









To retouch the still images

- ① Select the images you want to retouch while displaying in single-image or index mode.
- ② Touch [MENU].
- ③ Touch  (Retouch), then touch the desired mode.
- ④ Retouch the images by following the instructions for each retouching mode below.

- Touching **OK** in the Retouch screen enables checking of the effects that are currently set (except for  (Trimming) and  (Red Eye Correction)).
- Images cannot be retouched while the camera is connected to a TV.

 (Trimming)	<p>Records the zoomed playback image.</p>  <ol style="list-style-type: none"> ① Touch the image or press the T/W (Zoom) button to zoom in on the trimming range. ② Set the point with ///, then touch . ③ Select an image size with /, then touch . ④ Touch [Save]. <ul style="list-style-type: none"> • The quality of trimmed images may deteriorate. • The image size that you can trim may vary depending on the image.
 (Red Eye Correction)	<p>Corrects the red-eye phenomenon caused by flash.</p>  <p>After red eye correction is completed, touch [Save].</p> <ul style="list-style-type: none"> • You may not be able to correct the red-eye phenomenon depending on the image.

 (Soft Focus)	<p>Blurs the periphery around a chosen point to signalize a subject.</p>  <ol style="list-style-type: none"> ① Touch the center point of the desired image to retouch, then touch . ② Adjust the desired range to retouch with , then touch . ③ Select level of retouch with , then touch . ④ Touch [Save].
 (Partial Color)	<p>Surrounds a chosen point in monochrome to signalize a subject.</p>  <ol style="list-style-type: none"> ① Touch the center point of the desired image to retouch, then touch . ② Adjust the desired range to retouch with , then touch . ③ Touch [Save].
 (Fisheye Lens)	<p>Applies a fisheye effect around a chosen point.</p>  <ol style="list-style-type: none"> ① Touch the center point of the desired image to retouch, then touch . ② Select level of retouch with , then touch . ③ Touch [Save].
 (Cross Filter)	<p>Adds starburst effects to light sources.</p>  <ol style="list-style-type: none"> ① Adjust the desired length to retouch with , then touch . ② Select level of retouch with , then touch . ③ Touch [Save].

 (Radial Blur)	<p>Decides the center point for expressing movement in the still image.</p>  <ol style="list-style-type: none"> ① Touch the center point of the desired image to retouch, then touch . ② Adjust the desired range to retouch with / , then touch . ③ Touch [Save].
 (Retro)	<p>This softens the image by blurring the focus and lowering the surrounding light so that it appears as if it was taken by an old camera.</p>  <ol style="list-style-type: none"> ① Adjust the desired range to retouch with / , then touch . ② Select the level of retouch with / , then touch . ③ Touch [Save].



(Paint): Painting on still images



Paints characters or graphics on the still images, then saves them as new image.
See page 72.

(Slideshow): Playing back a series of images



Touch [MENU] →  (Slideshow) → .





See page 58.

To play back a slide show from the index screen

Touch  (Slideshow) and then touch the image from which you want to start the slide show.

 (Delete): Deleting images





Selects and deletes images on the single-image screen or the index screen, see page 41.

 (This Image)	Deletes the image that is now selected.
 (Multiple Images)	Selects and deletes multiple images.
 (Whole Album)	Deletes all the images in the selected album.
 (All In This Folder)	Deletes all the images in the selected folder in “Memory Stick Duo”.





 (Protect): Preventing accidental erasure

Protects images against accidental erasure.





The  (Protect) indicator appears on the protected image.

 (This Image)	Protects/unlocks the currently selected image.
 (Multiple Images)	Selects and protects/unlocks multiple images.
 (Select All in Album)	Protects all the images in the selected album.
 (Remove All in Album)	Unlocks all the images in the selected album.

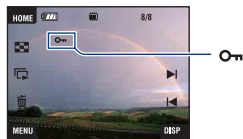





To protect an image

- 1 Display the image you want to protect.
- 2 Touch [MENU] to display the menu.
- 3 Display  (Protect) by touching /, then touch it.
- 4 Touch  (This Image).





**To select and protect images**

- 1 Touch [MENU] in single-image mode or in index mode.
- 2 Display  (Protect) by touching /, then touch it.
- 3 Touch  (Multiple Images).





In single-image mode:

- ④ Use   to display the image to be protected, and then touch the center of that image.
The  is attached to the selected image.
- ⑤ Touch   to display other images you want to protect, then touch the center of that image.
- ⑥ Touch  → [OK].

In index mode:

- ④ Touch the thumbnail image you want to protect.
The  is attached to the selected image.
 - ⑤ To protect other images, repeat step ④.
 - ⑥ Touch  → [OK].
- Touch   on the index screen to return to the single-image screen.



To select all the images in the album

- ① Touch [MENU] in index mode.
- ② Display  (Protect) by touching  , then touch it.
- ③ Touch  (Select All in Album).
All the images in the selected album are protected.

- Protection cannot be set when there are more than 100 files in an album. In this case, set the protection from [Multiple Images].

To cancel the protection

Select the image for which you want to cancel protection, and unlock it by performing the same procedure to protect it.

-  (Protect) indicator disappears.
- Touch  (Remove All in Album) to unlock all the images in the album.
- Note that the formatting erases all the data stored in the internal memory or “Memory Stick Duo”, even if the images are protected, and these images cannot be restored.
- It may take some time to protect an image.



 (Album View): Return to Album screen



Return from either Favorites or Sharemark screen to Album screen.





 (Print): Printing images using a printer

Printing images shot with the camera.
See page 102.

 (This Image)	You can print the image selected.
 (Multiple Images)	You can select and print multiple images.
 (Whole Album)	You can print all images in Album which is being selected.

 (Rotate): Rotating a still image



Rotates a still image.

- ① Display the image to be rotated.
- ② Touch [MENU] to display the menu.
- ③ Display  (Rotate) by touching ▲/▼, then touch it.
- ④ Touch  (Rotate).
- ⑤ Touch [ ] to rotate the image.
- ⑥ Touch [OK].

- You cannot rotate protected images or movies.
- You may not be able to rotate images shot with other cameras.
- When viewing images on a computer, the image rotation information may not be reflected depending on the software.

(Import): Importing images





You can copy (import) images in “Memory Stick Duo” to the internal memory.

 (This Image)	You can copy the selected image from “Memory Stick Duo” to the internal memory.
 (All In This Folder)	You can copy all the images in the folder from “Memory Stick Duo” to the internal memory.

- Images that can be played back on the camera will be imported.
- Each time you import images, a new album will be created as the date you imported.
- Images which the image size is larger than [8M] cannot be played back on the camera, even if imported.
- Use a battery fully charged. Copying images while using a battery with low charge may cause data transfer failure or cause damage to the data, due to running out of the battery.
- Images shot by another camera may not be able to play back.

(Export): Exporting images

You can copy (export) images in the internal memory to “Memory Stick Duo”.

 (This Image)	You can copy the selected image from the internal memory to “Memory Stick Duo”.
 (Whole Album)	You can copy all the images in Album from the internal memory to “Memory Stick Duo”.
 (All In Favorites)	You can copy all the images in Favorites from the internal memory to “Memory Stick Duo”.
 (All In Sharemark)	You can copy all the images in Sharemark from the internal memory to “Memory Stick Duo”.

- Each time you export images, a new folder will be created.
- Use “Memory Stick Duo” with sufficient memory space.
- Use a battery fully charged. Copying images while using a battery with low charge may cause data transfer failure or cause damage to the data, due to running out of the battery.
- Data in the internal memory will not be deleted after data transfer.

 (Select Folder): Selecting the folder for viewing images

Selects the folder containing the image you want to play back.

- ① Select the desired folder with ▲/▼.

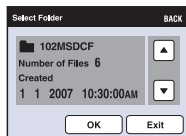

- ② Touch [OK].

To cancel selecting the folder

Touch [Exit] or [BACK] in step ②.

 On the folders

The camera stores images in a specified folder of a “Memory Stick Duo”. You can change the folder or create a new one.

- To create a new folder → [Create REC. Folder] (page 75).
- To change the folder for recording images → [Change REC. Folder] (page 76).
- When multiple folders are created in the “Memory Stick Duo” and the first or last image in the folder is displayed, the following indicators appear.

: Moves to the previous folder

: Moves to the next folder

: Moves to either the previous or next folders

 (Volume Settings): Adjusting the volume

Adjusts the volume.

See page 35.

 (Background): Changing the background

You can change the background of scrapbook.

See page 40.

Painting or putting stamps on still images (Paint)

You can paint or put stamps on still images and save them separately. Use the paint pen (supplied) for this operation.

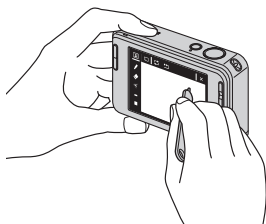

- You cannot paint in the following situation.
 - When playing back movies
 - When viewing recorded images on TV
 - When playing back images in “Memory Stick Duo”
 - When playing back images in Favorites or Sharemark

To display the painting

- ① Press (Playback) button.
- ② Touch [MENU] → (Paint) → (Paint).

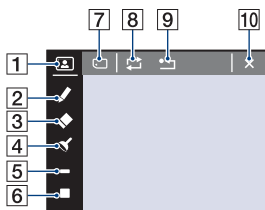

- 1 (frame) button
- 2 (pen) button
- 3 (eraser) button
- 4 (stamp) button
- 5 Thickness select button
- 6 Color select button
- 7 (save) button
- 8 (revert) button
- 9 (clear all) button
- 10 (exit) button





To paint characters or graphics

- ① Touch .
- ② Select the line thickness.
Touch the thickness select button, the desired thickness, then [BACK].
- ③ Paint characters or graphics.

To stamp

- ① Touch .
- ② Select a stamp.
Touch the stamp select button, the desired stamp, then [BACK].
- ③ Put stamps on the image.

To add a frame



- ① Touch .
- ② Select a frame.
Select the desired frame with  , then touch .

Touch [BACK] to return to the painting screen.

To change the color of the line

Touch the color select button, a desired color, then [BACK].

To make corrections

Touch , then rub the part you want to erase using the paint pen. Otherwise, touch  to revert to the previous state (if you touch  again, it returns to the latest state).

- You can select the thickness of the eraser in the same way as you do for the pen, using the thickness select button. The selected thickness is applied to both the line and eraser.

Erasing all painting

- ① Touch .
“Clear All” appears.
- ② Touch [OK].
All painting will disappear from the image.

Touch [Cancel] to cancel the operation.

To save the painting

- ① Touch .
- ② Touch the image size to be saved, then touch [OK].
The painted image is recorded in the album as the newest file.

Touch [Cancel] to cancel the operation.

- You can select the image size to be saved from [VGA] or [3M].

To exit paint mode

- ① Touch .
“Exit” appears.
- ② Touch [OK].

Touch [Cancel] to cancel the operation.



Customizing the Manage Memory feature and the Settings

You can change the default settings using  (Manage Memory) or  (Settings) on the HOME screen.

1 Touch [HOME] to display the HOME screen.



HOME

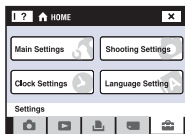

2 Touch (Manage Memory) or (Settings).



3 Touch the desired setting item.

Touch / to display the other setting items.

4 Touch the setting item that you want to change, and then touch the desired setting value to set it.

To cancel the setting change

Touch [Cancel] if it is shown as an option on the screen.
If not, touch [BACK] or [X].

- This setting is maintained even when the power is turned off.

Memory Tool — Memory Stick Tool

This item appears only when a “Memory Stick Duo” is inserted in the camera.

Format

Formats the “Memory Stick Duo”. A commercially available “Memory Stick Duo” is already formatted, and can be used immediately.

- Note that formatting irrevocably erases all data on a “Memory Stick Duo”, including even protected images.

- ① Touch [Format].
The message “All data on Memory Stick will be erased” appears.
- ② Touch [OK].
Formatting starts.

To cancel formatting

Touch [Cancel] or [BACK] in step ②.

Create REC.Folder

Creates a folder in a “Memory Stick Duo” for recording images.

- ① Touch [Create REC.Folder].
The message “Creating REC.folder” appears.



- ② Touch [OK].
A new folder is created with a number incremented one higher than the largest number, and the folder becomes the current recording folder.

To cancel the folder creation

Touch [Cancel] or [BACK] in step ②.

- When not creating a new folder, the “101MSDCF” folder is selected as the recording folder.
- You can create folders designated up to “999MSDCF”.
- You cannot delete a folder with the camera. To delete a folder, use your computer, etc.
- Images are recorded in the newly created folder until you create another folder or select another recording folder.
- Up to 4,000 images can be stored in one folder. When the folder capacity is exceeded, a new folder is automatically created.
- For details, see “Image file storage destinations and file names” (page 97).

Change REC.Folder

Changes the folder currently used for recording images.

- ① Touch [Change REC.Folder].
The folder selection screen appears.

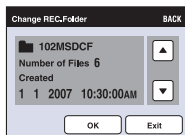

- ② Touch [OK].

To cancel changing the recording folder

Touch [Exit] or [BACK] in step ②.

- You cannot select the “100MSDCF” folder as a recording folder.
- You cannot move recorded images to another folder.

Mass Storage

When you connect the camera and a computer, the Mass Storage connection will be set to “Memory Stick Duo”.

- Load images in “Memory Stick Duo” to computers
- Copy images in computers to “Memory Stick Duo”

- ① Touch [Mass Storage].
The message “Connect to PC” appears.
- ② Connect the camera to your computer.

To connect the camera and a computer with USB cable, see page 96.

 **Memory Tool — Internal Memory Tool**

This item does not appear when a “Memory Stick Duo” is inserted in the camera.

Format

Formats the internal memory.

- Note that formatting permanently erases all data in the internal memory, including even protected images.

- ① Touch [Format].
The message “All data in internal memory will be erased” appears.
- ② Touch [OK].
Formatting starts.

To cancel formatting

Touch [Cancel] or [BACK] in step ②.

- When you format the internal memory, the embedded application “PMB Portable” will be erased together with the images. If you accidentally erase “PMB Portable”, re-install it from “Picture Motion Browser” (supplied). For details on how to operate, refer to “Picture Motion Browser Guide”.

Main Settings — Main Settings 1

The default settings are marked with .

Beep

Selects the sound produced when you operate the camera.

	Shutter	Turns on the shutter sound when you press the shutter button.
	On	Turns on the beep/shutter sound when you operate the touch panel/press the shutter button.
	Off	Turns off the beep/shutter sound.

Function Guide

When you operate the camera, the function guide appears.

	On	Displays the function guide.
	Off	Does not display the function guide.



Display of this guide can be turned on and off by the setting made above.

- The guide displayed by touching [?] cannot be turned on and off by the setting made above. Touch [?] again to hide the guide displayed by touching [?] (page 23).

Initialize

Initializes the setting to the default setting. Even if you execute this function, the images stored in the internal memory are retained.

- ① Touch [Initialize].
The message “Initialize all settings” appears.
- ② Touch [OK].
The settings are reset to the default setting.

To cancel Initializing

Touch [Cancel] or [BACK] in step ②.

- Be sure not to power off the camera while initializing.

Calibration

Enables you to perform calibration when the touch panel buttons do not react at the appropriate points where you touch.

Using the paint pen, touch the × mark displayed on the screen.

To stop the calibration process mid-way, touch [Cancel]. The adjustments made up to that point are not effected.

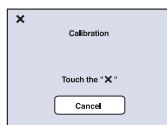

The × mark moves on the screen.

If you fail to press the right spot, the calibration is not performed. Press the × mark again.

Main Settings — Main Settings 2

The default settings are marked with .

USB Connect

Selects the USB mode to be used when connecting the camera to a computer or a PictBridge compliant printer using the USB cable (Only when using the internal memory).

	PictBridge	Connects the camera to a PictBridge compliant printer (page 102). When you connect the camera to a computer, the copy wizard starts automatically, and the images in the internal memory on the camera are copied to the computer. (with Windows XP/Vista)
	Mass Storage	Establishes a Mass Storage connection between the camera and a computer or other USB device (page 96).
	Auto	The camera recognizes automatically and sets up communication with a computer or PictBridge compliant printer (pages 96 and 102). <ul style="list-style-type: none"> • If you cannot connect the camera to a PictBridge compliant printer with the [Auto] setting, select [PictBridge]. • If you cannot connect the camera to a computer or a USB device with the [Auto] setting, select [Mass Storage].

COMPONENT

Selects the video signal output type from SD and HD(1080i), according to the TV connected (page 88).

	HD(1080i)	Select this item to connect the camera to a 1080i-capable High Definition TV.
	SD	Select this item to connect the camera to a TV that is not compatible with an HD(1080i) signal.

Video Out

Sets the video signal output according to the TV color system of the connected video equipment. The TV color systems differ depending on the country and region. To view images on a TV screen, check the TV color system of the country or region of use (page 89).

NTSC	Sets the video output signal to NTSC mode (e.g., for the USA, Japan).
PAL	Sets the video output signal to PAL mode (e.g., for Europe).





Shooting Settings — Shooting Settings 1

The default settings are marked with .

AF Illuminator



The AF illuminator supplies fill light to focus more easily on a subject in dark surroundings. The AF illuminator emits red light allowing the camera to focus easily when the shutter button is pressed halfway, until the focus is locked. The AF-ON indicator appears at this time.

	Auto	Uses the AF illuminator.
	Off	Does not use AF illuminator.

- If the AF illuminator light does not reach the subject sufficiently or the subject has no contrast, focus will not be achieved. (A distance of up to approximately 2.7 m (8 feet 10 3/8 inches) (zoom: W)/2.5 m (8 feet 2 1/2 inches) (zoom: T) is recommended.)
- Focus is achieved as long as the AF illuminator light reaches the subject, regardless of whether light fails to reach the center of the subject.
- You cannot use the AF illuminator when:
 - Focus preset is set (page 31).
 -  (Smile Shutter) mode,  (Twilight) mode,  (Landscape) mode or  (Fireworks) mode is selected in the Scene Selection mode.
 - The Face Detect function is activated.
- When you use AF illuminator, the normal AF range finder frame is disabled and new AF range finder frame is displayed by a dotted line. AF operates with priority on subjects located near the center of the frame.
- The AF illuminator emits very bright light. Although there is no health hazard, do not look directly into the AF illuminator emitter at close range.

Grid Line

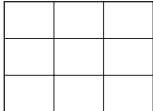
With reference to the grid lines, you can easily set a subject in a horizontal/vertical position.

	On	Displays the grid lines. 
	Off	Does not display the grid lines.

- The grid lines are not recorded.

AF Mode

Selects the auto focus operation mode.

<input checked="" type="checkbox"/>	Single	Automatically adjusts the focus when you press and hold the shutter button halfway down. This mode is useful for shooting stationary subjects.
<input type="checkbox"/>	Monitor	Automatically adjusts the focus before you press and hold the shutter button halfway down. This mode shortens the time needed for focusing. <ul style="list-style-type: none"> • Battery consumption is faster than in [Single] mode.

- When the Face Detect function is activated, the AF mode is disabled.

Digital Zoom

Selects the digital zoom mode. The camera enlarges the image using optical zoom (up to 3×). When the zoom scale is exceeded, the camera uses either smart or precision digital zoom.

<input checked="" type="checkbox"/>	Smart (Smart zoom) (sQ)	Enlarges the image digitally within the range where the image will not be distorted, according to the image size. This is not available when the image size is set to [8M] or [3:2]. <ul style="list-style-type: none"> • The maximum zoom scale of Smart zoom is shown in the following table.
<input type="checkbox"/>	Precision (Precision digital zoom) (PQ)	Enlarges all image sizes up to a maximum of 6×, but the image quality deteriorates.
<input type="checkbox"/>	Off	Does not use the digital zoom.

Image size and maximum zoom scale using Smart zoom

Size	Maximum zoom scale
5M	Approx. 3.8×
3M	Approx. 4.8×
VGA	Approx. 15×
16:9	Approx. 5.1×

- When the Face Detect function is activated, you cannot use the Digital Zoom.

Shooting Settings — Shooting Settings 2

The default settings are marked with .

Auto Orientation

When the camera is rotated to shoot a portrait (vertical) image, the camera records its position change and displays the image in the portrait position.

<input checked="" type="checkbox"/>	On	Records the image with the correct orientation.
<input type="checkbox"/>	Off	Auto Orientation deactivated.

- The left and right side of the image vertically orientated will be displayed in black.
- Depending on the shooting angle of the camera, the orientation of the image may not be recorded correctly. If an image is not recorded in the correct orientation, you can rotate the image, following the procedure on page 69.

Auto Review

Displays the recorded image on the screen for approximately two seconds immediately after shooting a still image.

<input checked="" type="checkbox"/>	On	Uses the Auto Review.
<input type="checkbox"/>	Off	Does not use Auto Review.

- If you press the shutter button halfway down, the recorded image display disappears and you can immediately shoot the next image.

Smile Level

This sets the smile detection level when  (Smile Shutter) (page 50) mode is selected in the Scene Selection.



<input type="checkbox"/>	High	Setting to [High] makes it easier to detect a smile.
<input checked="" type="checkbox"/>	Medium	
<input type="checkbox"/>	Low	

- The smile can be difficult to detect under the following conditions.
 - When the face of the subject is too dark or too bright and the exposure is not appropriate
 - When the face of the subject is far from the camera
 - When the subject is wearing sunglasses or glasses with thick frames
 - When the front hair, hat, or other objects are covering the eyes
 - When the subject is not facing towards the front

⌚ Clock Settings

Clock Settings

Sets the date and time.

- ① Select  (Clock Settings) from  (Settings) on the HOME screen.
- ② Touch [Clock Settings].
- ③ Touch the desired date display format, then touch .
The clock settings screen appears.

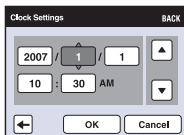
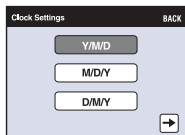

- ④ Touch each item, then set its numeric value by touching ▲/▼.
- ⑤ Touch [OK].

To cancel the clock setting

Touch [Cancel] or [BACK] in step ⑤.

A Language Setting

Language Setting

Selects the language to be used in the menu items, warnings and messages.



Viewing images on a TV

You can view images on a TV by connecting the camera to a TV.

The connection varies according to the type of TV the camera is connected to.

- Icons and other indicators do not appear on the TV.

Viewing images by connecting the camera to a TV with the cable for multi-use terminal (not supplied)

Turn off both the camera and the TV before connecting the camera to the TV.

1 Connect the camera to the TV with the cable for multi-use terminal (not supplied).

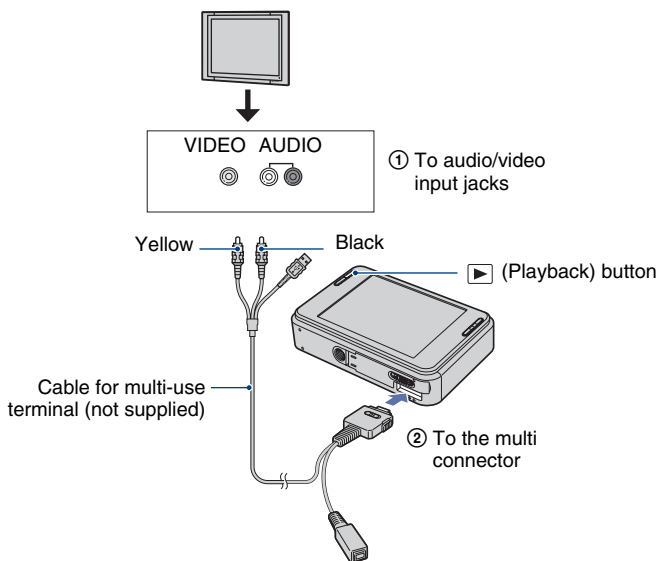

- Set the switch on the cable for multi-use terminal to "TV".
- If your TV has stereo input jacks, connect the audio plug (black) of the cable for multi-use terminal to the left audio jack (white).

2 Turn on the TV and set the input.

- Refer also to the operating instructions supplied with the TV.

3 Press (Playback) button to turn on the camera.

Images shot with the camera appear on the TV.

Touch  to select the desired image.

- When using the camera abroad, it may be necessary to switch the video signal output to match that of your TV system (page 80).

Viewing an image by connecting the camera to an HD TV

You can view an image recorded on the camera by connecting the camera to an HD (High Definition) TV* with the HD Output Adaptor Cable (not supplied).

Turn off both the camera and the TV before connecting the camera to the TV.

* Images taken at [VGA] resolution cannot be played back with high image quality.

- You can also enjoy viewing in high image quality with Cyber-shot Station CSS-HD1 (not supplied).

1 Connect the camera to an HD (High Definition) TV with a HD Output Adaptor Cable (not supplied).

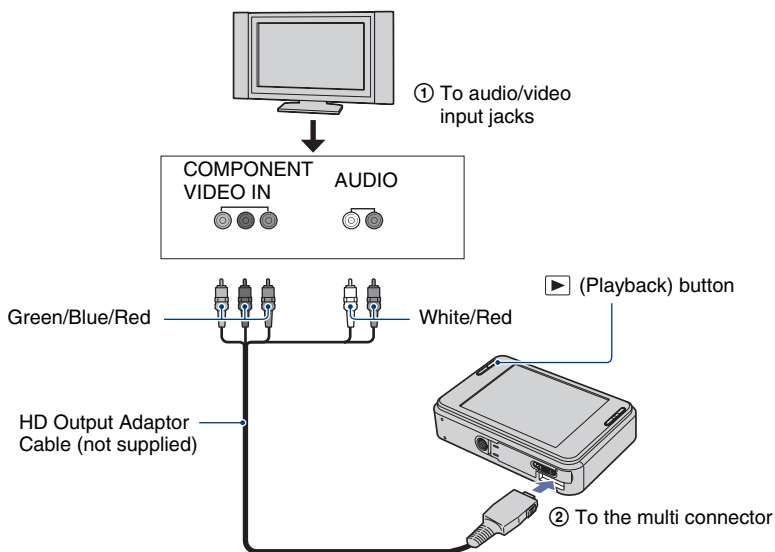

2 Turn on the TV and set the input.

- Refer also to the operating instructions supplied with the TV.

3 Press (Playback) button to turn on the camera.

Images shot with the camera appear on the TV.

Touch   to select the desired image.

- Set [COMPONENT] to [HD(1080i)] in [Main Settings 2] by selecting  (Settings) on the HOME screen (page 80).
- When using the camera abroad, it may be necessary to switch the video signal output to match that of your TV system (page 80).
- You cannot view movies output in HD signal format. Set [COMPONENT] to [SD].
- Scrapbook is displayed with its size reduced.

On “PhotoTV HD”

This camera is compatible with the “PhotoTV HD” standard.

By connecting Sony’s PhotoTV HD-compatible devices using an HD Output Adaptor Cable (not supplied), whole new world of photos can be comfortably enjoyed in breathtaking Full HD quality.

PhotoTV HD allows for a highly-detailed, photo-like expression of subtle textures and colors.

- The settings are also required to be made on the TV. For details, refer to the operating instruction of the TV.

On TV color systems

If you want to view images on a TV screen, you need a TV with a video input jack and the cable for multi-use terminal. The color system of the TV must match that of the digital still camera. Check the following lists for the TV color system of the country or region where the camera is used.

NTSC system

Bahama Islands, Bolivia, Canada, Central America, Chile, Colombia, Ecuador, Jamaica, Japan, Korea, Mexico, Peru, Surinam, Taiwan, the Philippines, the U.S.A., Venezuela, etc.

PAL system

Australia, Austria, Belgium, China, Czech Republic, Denmark, Finland, Germany, Holland, Hong Kong, Hungary, Italy, Kuwait, Malaysia, New Zealand, Norway, Poland, Portugal, Singapore, Slovak Republic, Spain, Sweden, Switzerland, Thailand, United Kingdom, etc.

PAL-M system

Brazil

PAL-N system

Argentina, Paraguay, Uruguay

SECAM system

Bulgaria, France, Guiana, Iran, Iraq, Monaco, Russia, Ukraine, etc.



Illustrations of screens used in this section are based on the English version.

- Under Windows Vista, some names and operations may differ from those described below.



Install the software (supplied) first (page 93)



- Installing the software as follows:
 - “Picture Motion Browser”
 - “Music Transfer”

Connecting to your computer (page 96)



- When you connect the camera and a computer with USB cable, “PMB Portable” will start up, and you can upload images with sharemarks on the Web by easy operation.
- Enjoying images using “Picture Motion Browser” and “Music Transfer” as follows:
 - Viewing images saved on your computer
 - Loading images of the camera to computers
 - Loading images of computers to the camera
 - Uploading images to the Web
 - Editing images
 - Displaying the shooting locations of still images on maps online
 - Creating a disc with the images shot (requires CD or DVD disc writing drive)
 - Printing or saving still images with the date
 - Adding/changing Music for slide show (using “Music Transfer”)

Additional information on this product and answers to frequently asked questions can be found at the Sony Customer Support Website.
<http://www.sony.net/>

Recommended computer environment

The following environment is recommended for a computer connected to the camera.

Recommended environment for using “Picture Motion Browser”, “PMB Portable” and “Music Transfer”

OS (pre-installed): Microsoft Windows 2000 Professional SP4, Windows XP* SP2/Windows Vista*

CPU/Memory: Pentium III 800 MHz or faster, 256 MB of RAM or more (Windows 2000/Windows XP), 1 GB of RAM or more (Windows Vista)

Hard Disk: Disk space required for installation—approximately 300 MB

Display: Screen resolution: 1024 × 768 dots or more

* 64-bit editions and Starter (Edition) are not supported.

Notes on connecting the camera to a computer

- Operations are not guaranteed for all the recommended computer environments mentioned above.
- If you connect two or more USB devices to a single computer at the same time, some devices, including the camera, may not operate, depending on the types of USB devices you are using.
- Operations are not guaranteed when using a USB hub.
- Connecting the camera using a USB interface that is compatible with Hi-Speed USB (USB 2.0 compliant) allows advanced transfer (high speed transfer) as the camera is compatible with Hi-Speed USB (USB 2.0 compliant).
- There are three modes for a USB connection when connecting a computer, [Auto] (default setting), [Mass Storage] and [PictBridge] modes. This section describes the [Auto] and [Mass Storage] as examples. For details on [PictBridge], see page 80.
- When your computer resumes from a suspend or sleep mode, communication between the camera and your computer may not recover at the same time.

Notes on the websites preset in “PMB Portable”

“PMB Portable” is preset with URL of several websites at factory setting. Give your consent to the following on using the image upload service, etc. (hereon after referred to as service) provided by the websites (including those preset) by using “PMB Portable”.

- Depending on websites, registration procedures or fees may be required on using the service.
- Follow the terms and conditions of the agreement set by the website on using the service.
- Termination or changes in service may occur depending on certain reasons of the website operator, etc. Including these situations, Sony is not held responsible for any troubles between customers and a third party or any loss to customers on using the service.

- To view the website, you will be redirected by a server run by Sony (hereon after referred to as Sony server). You may not be able to access the website because of server maintenance, etc.
- On termination of the operation of Sony server, the termination will be informed of beforehand on Sony websites, etc.
- The URL redirected to by Sony server, etc., may be recorded for improving future Sony products and services. In this case, personal data will not be recorded.

Installing the software (supplied)



You can install the software (supplied) using the following procedure.

- Log on as Administrator.

1 Turn on your computer, and insert the CD-ROM (supplied) into the CD-ROM drive.

The installation menu screen appears.



- If it does not appear, double-click  (My Computer) →  (SONYPICUTUTIL).
- Under Windows Vista, the AutoPlay screen may appear. Select “Run Install.exe.” and follow the instructions that appear on the screen to proceed with the installation.

2 Click [Install].

The “Choose Setup Language” screen appears.

3 Select the desired language, then click [Next].

The [Location Settings] screen appears.

4 Select the [Region] and [Country/Area], then click [Next].

When the [Welcome to the InstallShield Wizard for Sony Picture Utility] appears, click [Next].

The “License Agreement” screen appears. Read the agreement carefully. If you accept the terms of the agreement, click the radio button next to [I accept the terms of the license agreement] and then click [Next].

5 Follow the instructions on the screen to complete the installation.

- When the restarting confirmation message appears, restart the computer following the instructions on the screen.
- DirectX may be installed depending on the system environment of your computer.

6 Remove the CD-ROM after the installation is complete.

- Installing software as follows:
 - Picture Motion Browser
 - Music Transfer

After you install the software, a shortcut icon for the customers registration website is created on the desktop.

Once you register on the website, you can get secure and useful customer support.
<http://www.sony.net/registration/di>

Installing the software (supplied)

After you install the software, the short cut icons for “Picture Motion Browser”, “Picture Motion Browser Guide”, “Music Transfer” are created on the desktop.



- Double-click to start “Picture Motion Browser”.



- Double-click to start “Picture Motion Browser Guide”.



- Double-click to start “Music Transfer”.

On the “Picture Motion Browser” (supplied)

You can use still images and movies from the camera more than ever by taking advantage of the software.

This section summarizes the “Picture Motion Browser”.

“Picture Motion Browser” overview

With the “Picture Motion Browser” you can:

- Import images shot with the camera and display them on the computer.
- Organize images on the computer on a calendar by shooting date to view them.
- Edit images.
- Load images of computers to the camera.
- Retouch (Red Eye Correction, etc.), print, and send still images as e-mail attachments, change the shooting date and more.
- Still images can be printed or saved with the date.
- You can create a data disc using a CD burner drive or DVD burner drive.
- For details, refer to “Picture Motion Browser Guide”.

To access “Picture Motion Browser Guide”

- Double-click “Picture Motion Browser Guide” icon on the desktop.
- From the Start menu, click [Start] → [All Programs] (in Windows 2000, [Programs]) → [Sony Picture Utility] → [Help] → [Picture Motion Browser Guide].

Starting and exiting the “Picture Motion Browser”

Starting the “Picture Motion Browser”

Double-click the  (Picture Motion Browser) icon on the desktop.

Or, from the Start menu: Click [Start] → [All Programs] (in Windows 2000, [Programs]) → [Sony Picture Utility] → [Picture Motion Browser].

- The confirmation message of the Information tool appears on the screen when starting the “Picture Motion Browser” for the first time. Select [Start]. This function informs you of news, such as software updates. You can change the setting later.

Exiting the “Picture Motion Browser”

Click  button in the top right corner of the screen.

Connecting to computers

Preparing the camera and the computer

- 1 Connect the USB adaptor for Multi connector (supplied) and the USB cable (supplied).

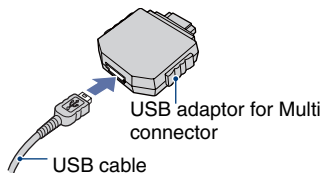

- 2 Insert the sufficiently charged battery pack in the camera.

- When you copy images to your computer using a battery pack with little remaining charge, copying may fail or image data may become corrupted if the battery runs out too soon. It is recommended to use an AC Adaptor (not supplied) and the USB, AV, DC IN cable for multi-use terminal (not supplied) or “Cyber-shot Station” (not supplied).

- 3 Press  (Playback), then turn on the computer.

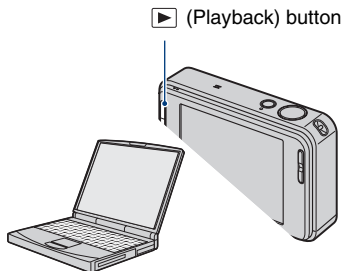

Connecting the camera to your computer

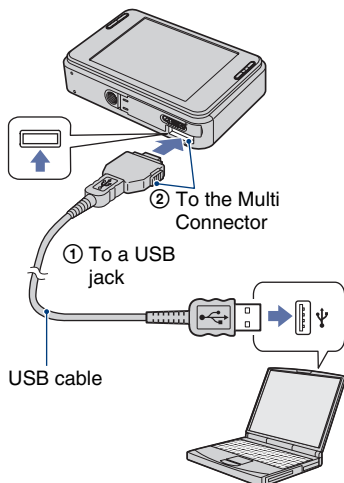

When you connect the camera and a computer with USB cable, “PMB Portable” will automatically start up.

- For details on how to operate “PMB Portable” see the Help within “PMB Portable”.
- When uploading images via Internet, including this product, note that depending on the Internet service provider, the cache may remain within the computer used.

To delete the USB connection

Perform the procedures from step ① to ④ below before:

- Disconnecting the USB cable.
- Removing a “Memory Stick Duo”.
- Inserting a “Memory Stick Duo” into the camera after copying images from the internal memory.
- Turning off the camera.

① Double-click  on the tasktray.



Double-click here

② Click  (USB Mass Storage Device) → [Stop].

③ Confirm the device on the confirmation window, then click [OK].

④ Click [OK].

The device is disconnected.

- Step ④ is unnecessary for Windows XP/ Vista.

Image file storage destinations and file names

The image files recorded with the camera are grouped as folders on the “Memory Stick Duo” or the internal memory.

Example: viewing folders on Windows XP

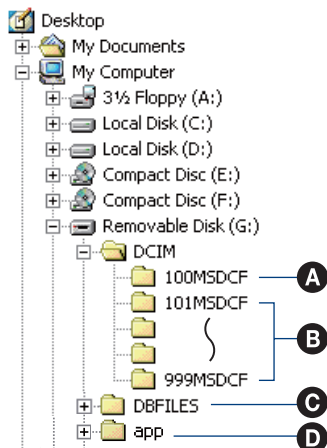

- A** Folder containing image data recorded using a camera not equipped with the folder creating function
 - B** Folder containing image data recorded using the camera
When not creating any folders, there is only the “101MSDCF” folder.
 - C** This folder may not appear on the screen, depending on your Windows setting. The DBFILES folder contains data, such as information used for album display. If you erase or edit these data, album display does not work properly. Never erase or edit data contained in the DBFILES folder.
 - D** Folder used in “PMB Portable”
- You cannot record any images to the “100MSDCF” folder. The images in this folder are available only for viewing.

- Image files are named as follows:
 - Still image files: DSC0□□□□.JPG
 - Movie files: MOV0□□□□.MPG
 - Index image files that are recorded when you record movies: MOV0□□□□.THM□□□□ stands for any number within the range from 0001 to 9999. The numerical portions of the name of a movie file recorded in movie mode and its corresponding index image file are the same.
- For more information about folders, see pages 71 and 75.
- The image may become unable to view with the camera if you move the folder.

Using the “Music Transfer” (supplied)

You can change the Music files that are preset at the factory to the desired Music files using “Music Transfer” in the CD-ROM (supplied). You can also delete or add these files whenever you want.

Adding/Changing Music using “Music Transfer”

The music formats you can transfer with “Music Transfer” are listed below:

- MP3 files stored on the hard disk drive of your computer
- Music on CDs
- Preset-music saved on this camera

- To restore the music preset at the factory to the camera:

- ① Perform [Format Music] in step 3.
- ② Execute [Restore defaults] on “Music Transfer”.

All Music files return to the preset-music, and [Music] in the [Slideshow] menu is set to [Off].

- You can reset the Music files to the preset ones using [Initialize] (page 78), however, other settings will also be reset.
- For details on using “Music Transfer”, see the on-line help in “Music Transfer”.

1 Touch [HOME] to display the HOME screen.

2 Touch  (Printing, Other), and touch [Music Tool].

3 Touch [Download Music].

The message “Connect to PC” appears.

4 Make a USB connection between the camera and your computer.

5 Start “Music Transfer”.

6 Follow the instructions on the screen to add/change Music files.

Viewing “Cyber-shot Step-up Guide”

When you install “Cyber-shot Handbook”, “Cyber-shot Step-up Guide” is also installed. “Cyber-shot Step-up Guide” further introduces how to use the camera and optional accessories.

Viewing on Windows

Start from the shortcut icon on the desktop.

How to print still images

When you print images shot in [16:9] mode, both edges may be cut off, so be sure to check before printing (page 113).

Printing directly using a PictBridge compliant printer (page 102)



You can print images by connecting the camera directly to a PictBridge compliant printer.

Printing directly using a “Memory Stick” compliant printer

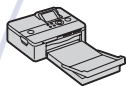

You can print images with a “Memory Stick” compliant printer. For details, see the operating instructions supplied with the printer.

Printing using a computer



You can copy images to a computer using the supplied “Picture Motion Browser” software and print the images. You can insert the date on the image and print it.

Printing at a shop

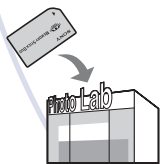

You can take a “Memory Stick Duo” containing images recorded with the camera to a photo printing service shop. DPOF setting function is not available in the camera.

Printing images directly using a PictBridge compliant printer

Even if you do not have a computer, you can print images shot using the camera directly to a PictBridge compliant printer.



- “PictBridge” is based on the CIPA standard. (CIPA: Camera & Imaging Products Association)
- You cannot print movies.
- If the  indicator flashes on the screen of the camera (error notification), check the connected printer.

Stage 1: Preparing the camera

Prepare the camera to connect it to the printer with the USB cable. When [USB Connect] is set to [Auto], the camera will automatically recognize certain printers when connected. Skip 1, if this is the case.

- It is recommended to use a fully charged battery pack to prevent the power from turning off partway through printing.

1 Touch [HOME] to display the HOME screen.

2 Touch  (Settings), and touch  Main settings].

3 Touch [Main Settings 2] and touch [USB Connect].

4 Touch [PictBridge].

The USB mode is set.

Stage 2: Connecting the camera to the printer

1 Connect the USB adaptor for Multi connector to the USB cable and connect the camera to the printer.

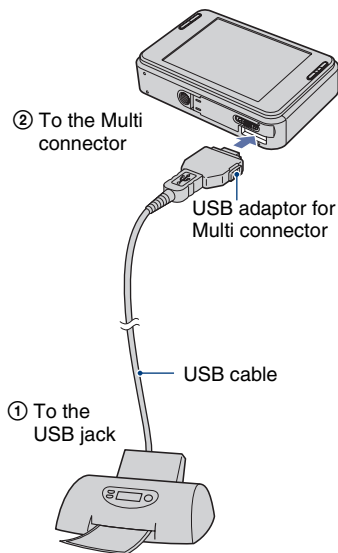

2 Turn on the camera and the printer.

After the connection is made, the  indicator appears.



Single image screen is displayed.

Stage 3: Selecting images you want to print

1 Touch [MENU] to display the MENU screen.

2 Touch / to display (Print), and touch (Print).

A print menu appears on the screen.



3 Touch [This Image] or [Multiple Images].

When you select [This Image]

You can print the selected image. Move on to Stage 4.

When you select [Multiple Images]

You can print multiple selected images.

- ① Touch the image you want to print.
The  mark appears on the selected image.
- ② Touch .
- ③ Touch [OK].

Stage 4: Printing

1 Touch the desired setting item to make the print settings.

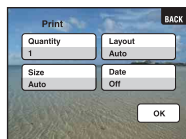

[Quantity]

When the [Layout] is set to [1-up/Borderless] or [1-up/Border]:

Select the number of sheets of an image that you want to print. The image will be printed as a single image.

When the [Layout] is not set to [1-up/Borderless] or [1-up/Border]:

Select the number of sets of images that you want to print as an index image. If you selected [This Image] in stage 3, select the number of the same image you want to print side by side on a sheet as an index image.

- The designated number of images may not all fit onto a single sheet depending on the quantity of images.

[Layout]

Selects the number of image you want to print side by side on a sheet.

[Size]

Select the size of the printing sheet.

[Date]

Select [Day & Time] or [Date] to insert the date and time on images.

- When you choose [Date], the date will be inserted in the order you select (page 84). This function may not be provided depending on the printer.

2 Touch [OK].

The image is printed.

- Do not disconnect the USB cable while the  (PictBridge Connecting) indicator appears on the screen.

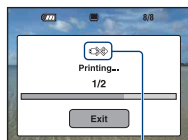

 indicator

To print other images

Select [Multiple Images], then perform the process again from stage 3.

Stage 5: Completing the printing

Make sure the screen has returned to stage 2, and disconnect the USB cable from the camera.



If you experience trouble with the camera or accessory, try the following solutions.

1 Check the items on pages 106 to 115.

If a code such as “C/E:□□:□□” appears on the screen, see page 116.

2 Remove the battery pack, wait for about one minute, re-insert the battery pack, then turn on the power.

3 Initialize the settings (page 78).

4 Consult your Sony dealer or local authorized Sony service facility.

On repairing cameras with internal memory or Music files function included, data in the camera may be checked on minimum necessity to verify and improve the malfunction symptoms. Sony will not copy or save any of those data.

Click one of the following items to jump to the page explaining the symptom and cause or the appropriate corrective action.

Battery pack and power	106	Internal memory	112
Shooting still images/movies	106	“Memory Stick Duo”	112
Viewing images	109	Printing	113
Deleting/Editing images	110	PictBridge compliant printer	113
Computers	110	Touch panel	115
Sharemark	112	Others	115

Battery pack and power

The battery pack cannot be inserted.

- Insert the battery pack correctly to push the battery eject lever.

Cannot turn on the camera.

- After inserting the battery pack into the camera, it may take a few moments for the camera to power up.
- Insert the battery pack correctly.
- The battery pack is discharged. Insert a charged battery pack.
- The battery pack is dead (page 123). Replace it with a new one.
- Use a recommended battery pack.

The power turns off suddenly.

- If you do not operate the camera for about three minutes while the power is on, the camera turns off automatically to prevent wearing down the battery pack. Turn on the camera again.
- The battery pack is dead (page 123). Replace it with a new one.

The remaining battery charge indicator is incorrect.



- This phenomenon occurs when you use the camera in an extremely hot or cold location.
- A discrepancy arose between the remaining battery charge indicator and the actual remaining battery charge. Fully discharge the battery pack once, then charge it to correct the indication.
- The battery pack is discharged. Insert a charged battery pack.
- The battery pack is dead (page 123). Replace it with a new one.

Cannot charge the battery pack.

- You cannot charge the battery pack using the AC Adaptor (not supplied). Use the battery charger to charge the battery.

Shooting still images/movies

Cannot record images.

- Check the free capacity of the internal memory. If it is full, do one of the following:
 - Delete unnecessary images (page 41).
 - Delete the image in the internal memory after copying it to “Memory Stick Duo”.
- You cannot record images while charging the flash.
- Set the shooting mode other than  in the HOME screen when shooting a still image.
- Set the shooting mode to  in the HOME screen when shooting movies.

This subject is not visible on the screen.

- The camera is set to the playback mode. Press  to change to the recording mode (page 35).





Anti-blur function does not work.

- The anti-blur function does not work when  appears on the display.
- The anti-blur function may not work properly when shooting night scenes.
- Shoot after pressing the shutter button halfway down. Do not press it fully down suddenly.

Recording takes a long time.

- The NR slow shutter function is activated (page 20). This is not a malfunction.









The image is out of focus.

- The subject is too close. Shoot in  (Macro On) recording mode. Make sure to position the lens farther away from the subject than the shortest shooting distance, approximately 8 cm (3 1/4 inches) (W)/25 cm (9 7/8 inches) (T), when shooting (page 30). Otherwise, set the camera to  (Close focus enabled) mode and shoot by focusing in on the subject at about 1 to 20 cm (13/32 to 7 7/8 inches) from the W side distance (page 30).
-  (Twilight) mode or  (Landscape) mode or  (Fireworks) mode is selected in the Scene Selection when shooting still images.
- The Focus preset function is selected. Select the auto focus mode (page 31).
- Refer to “How to use the [Spot AF]” on page 32.

Zoom does not work.

- You cannot use the Optical zoom when  (Close focus enabled) mode is selected.
- You cannot use the Smart zoom when the image size is set to [8M] or [3:2].
- You cannot use the Digital Zoom, when the Face Detect function is activated.





The flash does not work.

- The flash is set to  (Flash Off) (page 29).
- You cannot use the flash when:
 - [REC Mode] is set to [Burst] or Exposure Bracket (page 51).
 -  (High Sensitivity) mode or  (Twilight) mode or  (Fireworks) mode is selected in the Scene Selection (page 49).
 - Shooting in  (Close focus enabled) mode.
 - Shooting movies.
- Set the flash to  (Flash On) when  (Landscape) mode,  (Beach) mode, or  (Snow) mode is selected in the Scene Selection (page 29).

Fuzzy white circular spots appear in images shot using the flash.

- Particles (dust, pollen, etc.) in the air reflected the flash light and appeared in the image. This is not a malfunction (page 16).

The close-up shoot function (Macro/Close focus) does not work.

-  (Twilight) mode or  (Landscape) mode or  (Fireworks) mode is selected in the Scene Selection (page 49).
 -  (Close focus enabled) mode shooting is disabled when  (Smile shutter) mode is selected in the Scene Selection.
-

The date and time are not displayed on LCD screen.

- While shooting, the date and time are not displayed. They are displayed only during playback.
-

Cannot insert dates on images.

- This camera does not have a feature for superimposing dates on images (page 113). By using “Picture Motion Browser”, you can print or save images with the date.
-

The F value and shutter speed flash when you press and hold the shutter button halfway down.

- The exposure is incorrect. Correct the exposure (page 34).
-

The screen is too dark or too bright.

- Adjust the brightness of the backlight (page 24).
-

The image is too dark.

- You are shooting a subject with a light source behind the subject. Select the metering mode (page 33) or adjust the exposure (page 34).
-

The image is too bright.

- Adjust the exposure (page 34).
-

The image colors are not correct.

- Set [Color Mode] to [Normal] (page 54).
-

Vertical streaks appear when you are shooting a very bright subject.

- The smear phenomenon is occurring and white, black, red, purple, or other streaks appear on the image. This phenomenon is not a malfunction.
-

Noise appears in the image when you view the screen in a dark place.

- The camera is attempting to increase the visibility of the screen by temporarily brightening the image under conditions of low illumination. There is no effect on the recorded image.
-

The eyes of the subject come out red.

- Set [Red Eye Reduction] to [Auto] or [On] (page 56).
- Shoot the subject at a distance closer than the flash range using the flash.
- Light the room and shoot the subject.
- Retouch the image using [Red Eye Correction] (page 64).

Dots appear and remain on the screen.



- This is not a malfunction. These dots are not recorded (page 2).

Cannot shoot images in succession.

- The internal memory or “Memory Stick Duo” is full. Delete unnecessary images (page 41).
- The battery level is low. Install charged battery pack.

Viewing images

Cannot play back images.

- Press  (Playback) button or SCRAPBOOK button (page 35).
- The folder/file name has been changed on your computer.
- Sony does not guarantee playback of image files on your camera if the files have been processed using a computer or recorded with another camera.
- The camera is in USB mode. Delete the USB connection (page 97).
- When playing back images in “Memory Stick Duo”, set  (Memory Stick) in  (View Images) in HOME.
- Images in “Memory Stick Duo” cannot be played back with Scrapbook.

An error appears and images in album cannot be displayed.

- An error message will appear when there is a defect in the data of the camera. Use “Picture Motion Browser” (supplied) to load the images unable to play back on the camera to computers. By importing the data back to the camera again, the image will be able to be played back.

The date and time are not displayed.

- [Display Setup] is set to [Simple] or [Image Only]. Touch [DISP] to set [Display Setup] to [Normal] (page 24).

The image appears rough right after playback starts.

- This may happen due to image processing. This is not a malfunction.

The icons no longer appear.

- When the top right of the screen is touched, the icons will be momentarily disappear. Taking the finger off the screen makes the icons reappear.
 - [Display Setup] is set to [Image Only]. Set to [Normal] or [Simple].
-

The slideshow music (background music) does not play.

- Use “Music Transfer” to import music into the camera (page 99).
-

Left and right sides of the screen are shown in black.

- [Auto Orientation] is set to [On] (page 83).
-

The image does not appear on the TV.

- Check [Video Out] to see if the video output signal of the camera is set to the color system of your TV (page 80).
 - Check whether the connection is correct (page 86).
 - If the USB connector of the USB cable is connected to another device, disconnect it (page 97).
 - You are trying to play back movies in HD(1080i) output. Recorded movies cannot be viewed at high-definition image quality. Set [COMPONENT] to [SD] (page 80).
-

Deleting/Editing images

Cannot delete an image.

- Cancel the protection (page 67).
-

Cannot paint/retouch.

- You cannot paint or retouch the following images.
 - Movies
 - When viewing images on TVs connected to the camera
 - Images in “Memory Stick Duo”
 - Images in Favorites or Sharemark
-

Computers

Computer OS compatibility with camera is unknown.

- Check “Recommended computer environment” on page 91.

“Memory Stick PRO Duo” is not recognized by a computer with a “Memory Stick” slot.

- Check that the computer and the Memory Stick Reader/Writer support “Memory Stick PRO Duo”. Users of computers and Memory Stick Readers/Writers made by manufacturers other than Sony should contact those manufacturers.
- If “Memory Stick PRO Duo” is not supported, connect the camera to the computer (page 96). The computer recognizes the “Memory Stick PRO Duo”.

Your computer does not recognize the camera.

- Turn on the camera.
- When the battery level is low, install the charged battery pack or use the AC adaptor (not supplied) (page 96).
- Set [USB Connect] to [Mass Storage] (page 80).
- Use the USB cable (supplied) (page 96).
- Disconnect the USB cable from both the computer and the camera, and connect it again firmly.
- Disconnect all equipment other than the camera, the keyboard and the mouse from the USB connectors of your computer.
- Connect the camera directly to your computer without passing through a USB hub or other device (page 96).
- When loading images in “Memory Stick Duo” to computers, select  (Memory Tool) → [Memory Stick Tool] → [Mass Storage] in HOME.

Cannot copy images.

- Connect the camera and your computer correctly making a USB connection (page 96).
- Follow the designated copy procedure for your OS.
- When you shoot images with a “Memory Stick Duo” formatted by a computer, you may not be able to copy the images to a computer. Shoot using a “Memory Stick Duo” formatted by the camera (page 75).

After making a USB connection, “Picture Motion Browser” does not start automatically.

- Make the USB connection after the computer is turned on (page 96).

Cannot play back images on your computer.

- If you are using “Picture Motion Browser”, refer to “Picture Motion Browser Guide” (page 95).
- Consult the computer or software manufacturer.

You do not know how to use “Picture Motion Browser”.

- Refer to “Picture Motion Browser Guide” (page 95).

The image and sound are interrupted by noise when you view a movie on a computer.

- You are playing back the movie directly from the internal memory or the “Memory Stick Duo”. Copy the movie to the hard disk of your computer, then play back the movie from the hard disk (page 96).

Cannot print an image.

- Refer to the operation manual of the printer.

Images once copied to a computer cannot be viewed on the camera.

- Copy them to a folder recognized by the camera, such as “101MSDCF” in “Memory Stick Duo” (page 97).
- The image was copied from a computer to the internal memory of the camera by Mass Storage connection, therefore the album image does not exist. Use “Picture Motion Browser” (supplied) to copy images to the camera.

Sharemark

Cannot upload to Web.

- Check if the camera is connected to a computer with USB cable (page 96).
- When you format the internal memory, the embedded application “PMB Portable” will also be deleted. Use “Picture Motion Browser” (supplied) and re-install “PMB Portable”.

Internal memory

Cannot copy the data stored in the internal memory to a “Memory Stick Duo”.

- The “Memory Stick Duo” is full. Copy to a “Memory Stick Duo” with sufficient free capacity.

“Memory Stick Duo”

Cannot insert a “Memory Stick Duo”.

- Insert it in the correct direction.

You have formatted a “Memory Stick Duo” by mistake.

- All the data on the “Memory Stick Duo” is deleted by formatting. You cannot restore it.

Cannot save images.

- Images shot with the camera are saved in the internal memory. If the internal memory has available memory left, the image will not be recorded in “Memory Stick Duo” even if it is inserted in the camera. The images will be recorded in “Memory Stick Duo” after the internal memory is full.

Printing

See “PictBridge compliant printer” together with the following items.

Images are printed with both edges cut off.

- Depending on your printer, all the edges of the image may be cut off. Especially when you print an image shot with the image size set to [16:9], the lateral end of the image may be cut off.
- When printing images using your printer, cancel the trimming or borderless settings. Consult the printer manufacturer as to whether the printer provides these functions or not.
- When having images printed at a digital print shop, ask the shop whether they can print the images without cutting off both edges.

Cannot print images with the date.

- Using “Picture Motion Browser”, you can print images with date.
- This camera does not have a feature for superimposing dates on images. However, because the images shot with the camera include information on the recording date, you can print images with the date superimposed if the printer or the software can recognize Exif information. For compatibility with Exif information, consult the manufacturer of the printer or the software.
- If you use a photo printing service, ask them to superimpose the dates on images.

PictBridge compliant printer

A connection cannot be established.

- The camera cannot be connected directly to a printer that is not compliant with the PictBridge standard. Consult the printer manufacturer as to whether the printer is compliant with PictBridge or not.
- Check that the printer is turned on and can be connected to the camera.
- Set [USB Connect] to [PictBridge] (page 80).
- Disconnect and connect the USB cable again. If an error message is indicated on the printer, refer to the operating instructions supplied with the printer.

Cannot print images.

- Check that the camera and the printer are properly connected using the USB cable.
- Turn on the printer. For further information, refer to the operating instructions supplied with the printer.
- If you select [Exit] during printing, images may not be printed. Disconnect and connect the USB cable again. If you still cannot print your images, disconnect the USB cable, turn the printer off and then on, then connect the USB cable again.
- Movies cannot be printed.
- Images shot using cameras other than this camera or images modified with a computer may not be printed.

Printing is canceled.

- You have disconnected the USB cable before the  (PictBridge Connecting) mark disappears.

Cannot insert the date or print images in the index mode.

- The printer does not provide these functions. Consult the printer manufacturer as to whether the printer provides these functions or not.
- The date may not be inserted in the index mode depending on the printer. Consult the printer manufacturer.

“---- -- --” is printed on the date-inserted part of the image.

- The image does not have the recording data so the date cannot be inserted. Set [Date] to [Off] and print the image again (page 103).

Cannot select the print size.

- Consult the printer manufacturer as to whether the printer can provide the desired size.

Cannot print the image at the size selected.

- When you use paper of a different size after connecting the printer to the camera, disconnect and then reconnect the USB cable.
- The print setting of the camera differs from that of the printer. Change the setting of either the camera (page 103) or the printer.

Cannot operate the camera after canceling printing.

- Wait for a while as the printer is carrying out the cancellation. It may take some time depending on the printer.

Touch panel

Cannot operate the touch panel buttons correctly or fully.

- Perform [Calibration] (page 79).

The paint pen operation reacts at inappropriate points.

- Perform [Calibration] (page 79).

Others

The file number cannot be reset.

- The file number will not be reset even if you change the recording media. To reset, perform [Format] (pages 75, 77) with the camera, and then perform [Initialize] (page 78). However, all data will be erased, and all settings including the date and time are cancelled.

The lens gets fogged.

- Moisture condensation has occurred. Turn off the camera and leave it for about an hour before using it.

The camera becomes warm when you use it for a long time.

- This is not a malfunction.

The Clock Set screen appears when you turn on the camera.

- Set the date and time again (page 84).

You want to change the date or time.

- Set the date and time again (page 84).

Warning indicators and messages

Self-diagnosis display

If a code starting with a letter of the alphabet appears, the self-diagnosis function on the camera is working. The last two digits (indicated by □□) will differ depending on the state of the camera.

If you cannot solve the problem even after trying the following corrective actions a few times, the camera may need repair. Contact your Sony dealer or local authorized Sony service facility.

C:32:□□

- There is trouble with the camera's hardware. Turn the power off and on again.

C:13:□□

- The camera cannot read or write data on the "Memory Stick Duo". Try turning off and on the camera again, or taking out and inserting the "Memory Stick Duo" several times.
- The internal memory has experienced a format error, or an unformatted "Memory Stick Duo" is inserted. Format the internal memory or the "Memory Stick Duo" (pages 75, 77).
- The inserted "Memory Stick Duo" cannot be used with the camera, or the data is damaged. Insert a new "Memory Stick Duo".

E:61:□□

E:62:□□

E:91:□□

- A camera malfunction has occurred. Initialize the camera (page 78), then turn the power on again.

Messages

If the following messages appear, follow the instructions.



- The battery level is low. Charge the battery pack immediately. Depending on the conditions of use or the type of battery pack, the indicator may flash even though there are still 5 to 10 minutes of remaining battery time left.

For use with compatible battery only

- The battery inserted is not an NP-BD1/ NP-FD1 battery pack.

System error

- Turn the power off and then on again.

Album data error

Album is damaged. To repair use "Picture Motion Browser".

- Use "Picture Motion Browser" to load images to computers. The image cannot be played back on the camera. You can load/save images by using "Picture Motion Browser".

Internal memory error

- Turn the power off and then on again.

Reinsert the Memory Stick

- Insert the "Memory Stick Duo" correctly.
- The inserted "Memory Stick Duo" cannot be used in the camera (page 121).
- The "Memory Stick Duo" is damaged.
- The terminal section of the "Memory Stick Duo" is dirty.

Memory Stick type error

- The inserted “Memory Stick Duo” cannot be used in the camera (page 121).

Cannot access Memory Stick Access denied

- You are using the “Memory Stick Duo” with the access controlled.

Memory Stick formatting error Internal memory formatting error

- Format the media again (pages 75, 77).

Memory Stick locked

- You are using the “Memory Stick Duo” with the write-protect switch, and the switch is set to the LOCK position. Set the switch to the recording position.

No memory space in internal memory

No memory space on Memory Stick

- Delete unnecessary images or files (page 41).

Read only memory

- The camera cannot record or delete images on this “Memory Stick Duo”.

No Images

- No images that can be played back have been recorded in the internal memory.
- No images that can be played back have been recorded in this album.
- The selected album does not contain a file that can be played in a Slide Show with music.

Folder error

- A folder with the same first three digit number already exists on the “Memory Stick Duo” (for example: 123MSDCF and 123ABCDE). Select another folder, or create a new folder (pages 75, 76).

Cannot create more folders

- The folder with a name beginning with “999” exists on the “Memory Stick Duo”. You cannot create any folders if this is the case.

File error

- An error occurred while the image was playing back.
- When an image file has been processed by a computer or when the image file was recorded using a model other than that of your camera, playback on your camera is not guaranteed.

Read only folder

- You have selected a folder that cannot be set as a recording folder on the camera. Select another folder (page 76).

File protect

- Release the protection (page 67).

Image size over

- You are playing back an image with size that cannot be played back on the camera.

Invalid operation

- You are trying to play back a file that is not compatible with the camera.
- You have selected a function that is not available for movies.
- You have touched the panel when using the digital zoom or close focus mode. While using these modes, you cannot focus by touching the screen.



(Vibration warning indicator)

- Camera shake may occur due to insufficient light. Use the flash, turn on the anti-blur function, or mount the camera on a tripod to secure the camera.

Macro is invalid

- The macro is unavailable under these settings (pages 30, 49).

Flash settings cannot be changed

- The flash is unavailable under these settings (pages 29, 49).

Zoom disabled

- You cannot use optical zoom in close focus mode.

Maximum images selected

- You can select up to 100 images. Remove the check mark.

No enough battery

- When copying (import/export) images, use a battery fully charged.

Printer busy

Paper error

No Paper

Ink error

Low Ink

No Ink

- Check the printer.

Printer error

- Check the printer.
- Check if the image you want to print is corrupted.



- The data transmission to the printer may not be completed yet. Do not disconnect the USB cable.

Processing...

- The printer is canceling the current print job. You cannot print until it is finished. This may take time, depending on the printer.

Music Error

- Delete the Music file, or replace it with a normal Music file.
- Execute [Format Music], then download a new Music files.

Format Music Error

- Execute [Format Music].

Invalid operation

HD(1080i) output in progress...

- You are trying to play back movies.
- You are trying to use the [Retouch] function.

TV output in progress...

- The camera is playing back images in the Slide Show mode.

No red-eye detected

- You may not be able to correct the red-eye phenomenon depending on the image.



You can use the camera, the battery charger (supplied), and the AC-LS5K AC Adaptor (not supplied) in any country or region where the power supply is within 100 V to 240 V AC, 50/60 Hz.

- **Do not use an electronic transformer (travel converter), as this may cause a malfunction.**

On the “Memory Stick Duo”

A “Memory Stick Duo” is a compact, portable IC recording medium. The types of “Memory Stick Duo” that can be used with the camera are listed in the table below. However, proper operation cannot be guaranteed for all “Memory Stick Duo” functions.

“Memory Stick Duo” type	Recording/ Playback
Memory Stick Duo (without MagicGate)	○*2
Memory Stick Duo (with MagicGate)	○*1
MagicGate Memory Stick Duo	○*1*2
Memory Stick PRO Duo	○*1*4
Memory Stick PRO-HG Duo	○*1*3*4

*1 “Memory Stick Duo”, “MagicGate Memory Stick Duo” and “Memory Stick PRO Duo” are equipped with MagicGate functions. MagicGate is copyright protection technology that uses encryption technology. Data recording/playback that requires MagicGate functions cannot be performed with the camera.

*2 High-speed data transfer using a parallel interface is not supported.

*3 This camera does not support 8-bit parallel data transfer. It performs the same 4-bit parallel data transfer as the “Memory Stick PRO Duo”.

*4 [640(Fine)] size movies can be recorded.

- This product is compatible with “Memory Stick Micro” (“M2”). “M2” is an abbreviation for “Memory Stick Micro”.
- A “Memory Stick Duo” formatted with a computer is not guaranteed to operate with the camera.
- Data read/write speeds differ depending on the combination of the “Memory Stick Duo” and the equipment used.
- Do not remove the “Memory Stick Duo” while reading or writing data.

- Data may be corrupted in the following cases:
 - When the “Memory Stick Duo” is removed or the camera is turned off during a read or write operation
 - When the “Memory Stick Duo” is used in locations subject to static electricity or electrical noise
- We recommend backing up important data.
- Do not press down hard when you write down on the memo area.
- Do not attach a label on the “Memory Stick Duo” itself nor on a Memory Stick Duo Adaptor.
- When you carry or store the “Memory Stick Duo”, put it in the case supplied with it.
- Do not touch the terminal section of the “Memory Stick Duo” with your hand or a metal object.
- Do not strike, bend or drop the “Memory Stick Duo”.
- Do not disassemble or modify the “Memory Stick Duo”.
- Do not expose the “Memory Stick Duo” to water.
- Do not leave the “Memory Stick Duo” within the reach of small children. They might accidentally swallow it.
- Do not insert anything other than a “Memory Stick Duo” into the “Memory Stick Duo” slot. Doing so will cause a malfunction.
- Do not use or store the “Memory Stick Duo” under the following conditions:
 - High temperature locations such as the hot interior of a car parked in direct sunlight
 - Locations exposed to direct sunlight
 - Humid locations or locations with corrosive substances present

Notes on using the Memory Stick Duo Adaptor (not supplied)

- To use a “Memory Stick Duo” with a “Memory Stick” compliant device, be sure to insert the “Memory Stick Duo” into a Memory Stick Duo Adaptor. If you insert a “Memory Stick Duo” into a “Memory Stick” compliant device without a Memory Stick Duo Adaptor, you might not be able to remove it from the device.
- When inserting a “Memory Stick Duo” into a Memory Stick Duo Adaptor, make sure the “Memory Stick Duo” is inserted facing in the correct direction, then insert it all the way in. Incorrect insertion may result in a malfunction.
- When using a “Memory Stick Duo” inserted into a Memory Stick Duo Adaptor with a “Memory Stick” compliant device, make sure that the Memory Stick Duo Adaptor is inserted facing the correct direction. Note that improper use may damage the equipment.
- Do not insert a Memory Stick Duo Adaptor into a “Memory Stick” compliant device without a “Memory Stick Duo” attached. Doing so may result in malfunction of the unit.

Notes on using “Memory Stick PRO Duo” (not supplied)

“Memory Stick PRO Duo” with a capacity up to 8 GB have been confirmed to operate properly with the camera.

Notes on using “Memory Stick Micro” (not supplied)

- To use a “Memory Stick Micro” with the camera, be sure to insert the “Memory Stick Micro” into an “M2” Adaptor as large as of Duo size. If you insert a “Memory Stick Micro” into the camera without an “M2” Adaptor as large as of Duo size, you might not be able to remove it from the camera.
- Do not leave the “Memory Stick Micro” within the reach of small children. They might accidentally swallow it.

On the battery pack

On charging the battery pack

We recommend charging the battery pack in an ambient temperature of between 10°C to 30°C (50°F to 86°F). The battery pack may not be fully charged in temperatures outside this range.

Effective use of the battery pack

- Battery performance decreases in low temperature surroundings. So in cold places, the operational time of the battery pack is shorter. We recommend the following to ensure longer battery pack use:
 - Put the battery pack in a pocket close to your body to warm it up, and insert it in the camera immediately before you start shooting.
- The battery pack will run out quickly if you use the flash or zoom frequently.
- We recommend having spare battery packs handy for two or three times the expected shooting time, and making trial shots before taking the actual shots.
- Do not expose the battery pack to water. The battery pack is not water-resistant.
- Do not leave the battery pack in extremely hot places, such as in a car or under direct sunlight.

How to store the battery pack

- Fully discharge the battery pack before storing and store it in a cool, dry place. To maintain the battery pack's function, fully charge the battery pack and then fully discharge it on the camera at least once a year while storing.
- To use the battery pack up, leave the camera in slide show (page 58) playback mode until the power goes off.
- To prevent staining the terminal, short-circuiting, etc., be sure to use a supplied battery case when carrying and storing.

On battery life

- The battery life is limited. Battery capacity decreases over time and through repeated use. If decreased usage time between charges becomes significant, it is probably time to replace it with a new one.
- The battery life varies according to how it is stored and the operating conditions and environment in which each battery pack is used.

Compatible battery pack

- The NP-BD1 (supplied) can be used only in D type compatible Cyber-shot models. It cannot be used in Cyber-shot models compatible with the T type and other battery types.
- If the NP-FD1 battery pack (not supplied) is used, the minute display ( 60 Min) is also shown after the battery remaining indicator.

On the battery charger

On the battery charger

- Only D-type, T-type, R-type and E-type battery packs (and no others) can be charged in the battery charger (supplied). Batteries other than the specified kind may leak, overheat, or explode if you attempt to charge them, posing a risk of injury from electrocution and burns.
- The batteries that are compatible with the camera are D type batteries. The supplied battery is NP-BD1 (D type).
- Remove the charged battery pack from the battery charger. If you leave the charged battery pack in the charger, battery life may be shortened.
- If the CHARGE lamp flashes, remove the battery that is being charged and then reinsert it correctly. If the CHARGE lamp flashes again, the battery may be malfunctioning or a battery other than the specified kind may have been inserted. Check that the battery is of the specified kind.

If the inserted battery is of the specified kind, remove the battery and insert a different or new battery to check whether the battery charger is working properly. If the battery charger is working properly, the battery is probably malfunctioning.

On “Cyber-shot Station”

On “Cyber-shot Station”

The following Cyber-shot Station (not supplied) are compliant to the camera.

- CSS-HD1 (with the remote controller)
- CSS-PC1

Using the Cyber-shot Station (not supplied) enables faster charging than the supplied battery charger and easy connection to a TV or computer.

For details, refer to the operating instructions supplied with the Cyber-shot Station.

Placing the camera on the Cyber-shot Station

Before mounting the camera to the Cyber-shot Station, the adaptor plate supplied with the camera must be mounted.

Placing the adaptor plate

- ① Set the MODEL SELECT switch to A.
- ② Place the adaptor plate on the Cyber-shot Station.

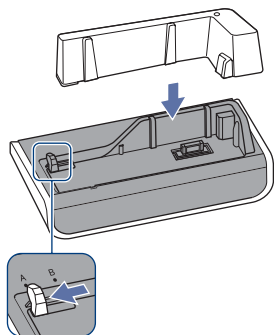

- ③ Placing the camera on the Cyber-shot Station.

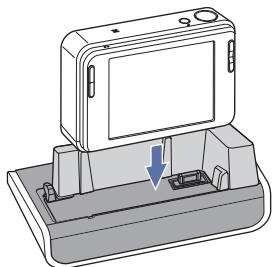

Operating the Cyber-shot Station with the remote

When the remote supplied with the CSS-HD1 is used with the camera, the following operations are available.

- For details on buttons not described here, refer to the instruction manual supplied with the Cyber-shot Station.

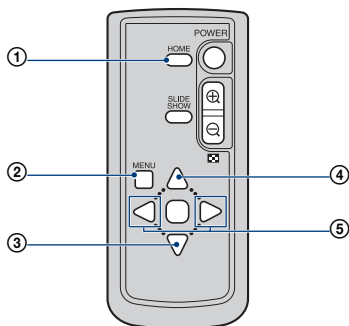

① **HOME button:** This button is invalid.

② **MENU button:** Displays the setting screen of the Slide show (page 58).

- The slideshow setting screen is different during remote control operation, but the setting items are the same.

③ **▼ button:** This button is invalid.

④ **▲ button:** Changes the screen display.

⑤ **◀/▶ button:** Displays the previous/next image.



- A**
- Adaptor plate125
 - Add/Remove Favorites61
 - Add/Remove Sharemark.....62
 - Adjusting EV34
 - AE/AF lock indicator.....27
 - AF Illuminator81
 - AF Mode.....82
 - AF range finder frame31
 - AF range finder frame indicator31
 - Album List.....37, 58
 - Album View68
 - Aperture12
 - Auto Adjustment mode.....26
 - Auto Focus.....10
 - Auto Orientation83
 - Auto Review83
 - Automatic image management8
- B**
- B & W.....55
 - Background.....40, 71
 - Battery charger.....124
 - Battery pack123
 - Beach mode48
 - Beep78
 - Blur11
 - Burst.....51
- C**
- Calendar.....38, 58
 - Calibration79
 - Center AF31
 - Center-weighted metering ...33
 - Change REC.Folder.....76
 - Clock Settings.....84
 - Close focus30
 - Cloudy53
- D**
- Color.....13, 73
 - Color Mode54
 - COMPONENT.....80
 - Computer.....90
 - Recommended environment91
 - Software.....93
 - Windows90
 - Connecting
 - Computer96
 - Printer.....102
 - TV86
 - Create REC.Folder75
 - Cross Filter.....65
- D**
- Date84, 103
 - Daylight.....53
 - Delete41, 67
 - Format.....75, 77
 - Deleting images.....41
 - Digital Zoom82
 - DirectX.....93
 - DISP.....24
 - Download Music99
- E**
- Electronic transformer.....120
 - EV34
 - Export.....70
 - Exposure.....12
 - Exposure Bracket52
- F**
- Face Detection.....56
 - Favorites.....8, 61
 - File name.....97
 - File storage destination97
 - Fireworks mode.....48
 - Fisheye Lens65
 - Flash29
 - Flash (Shooting)16
 - Flash Level55
 - Flash mode.....29
 - Flash Off.....29
 - Flash On.....29
 - Flash (White Balance)54
 - Flexible Spot AF.....31
 - Fluorescent Light 1, 2, 3.....53
 - Focus preset.....32
 - Focus.....10, 27, 31
 - Folder.....71
 - Changing76
 - Creating.....75
 - Selecting.....71
 - Format.....75, 77
 - Format Music.....99
 - Function Guide78
- G**
- Grid Line81
- H**
- HD(1080i).....80
 - High Sensitivity mode48
 - Hi-Speed Shutter mode.....48
 - Histogram25
 - HOME43
 - HOME items.....44
- I**
- Identifying parts.....17
 - Image file storage destinations and file names.....97
 - Image quality14
 - Image size.....14, 28
 - Import70
 - Incandescent53
 - Index screen.....37
 - Indicator.....18

- Initialize 78
 Install 93
 internal memory 7
 Internal Memory Tool 77
 ISO 12, 13, 34
- J**
- JPG 98
- L**
- Landscape mode 48
 Language Setting 85
 LCD Screen 24
- M**
- Macro 30
 Main Settings 1 78
 Main Settings 2 80
 Manage Memory 75
 Mass Storage 76, 80
 “Memory Stick Duo” 121
 Memory Stick 60
 Memory Stick Tool 75
 Menu
 Items 46
 Shooting 47, 51
 Viewing 61
 Metering Mode 33
 Monitor 82
 Movie Mode 47
 MPG 98
 Multi AF 31
 Multi connector
 17, 86, 102
 Multi-pattern metering 33
 Music 59
 Music Tool 99
 Music Transfer 99
- N**
- Natural 54
 NR slow shutter 20
 NTSC 80
- O**
- Optical zoom 28, 82
 OS 91
 Overexposure 12
- P**
- Paint pen 72
 Paint 66
 PAL 80
 Partial Color 65
 PC 90
 PictBridge 80, 102
 Picture Motion Browser
 95
 Pixel 14
 Playback zoom 36
 Precision digital zoom 82
 Pressing halfway down 10
 Print 69, 101
 Printing directly 102
 Printing, Other 44
 Program Auto mode 47
 Protect 67
- R**
- Radial Blur 66
 REC Mode 51
 Red Eye Correction 64
 Red Eye Reduction 56
 Remove Favorites 63
 Remove Sharemark 63
 Retouch 64
 Retro 66
 Rewind/Fast forward 35
 Rotate 69
- S**
- Scene Selection 48
 SCRAPBOOK 39
 Scrapbook 8
 Screen
 Changing the display 24
 Indicator 18
 LCD backlight 24
 SD 80
 Select Folder 71
 Self-diagnosis display 116
 Self-timer 28
 Sepia 55
 Settings 78
 Setup 57
 Sharemark 62
 Shooting 47
 Movies 27
 Still image 26
 Shooting menu 51
 Shooting Settings 1 81
 Shooting Settings 2 83
 Shutter speed 12
 Single 82
 Slideshow 58, 66
 Slow Synchro 29
 Smart zoom 82
 Smile Level 83
 Smile Shutter 50
 Snow mode 48
 Soft Focus 65
 Soft Snap mode 48
 Software 93, 95, 99
 Spot AF 31
 Spot metering 33
 Spot metering cross hairs 33
 SteadyShot 57

T

Touch panel	23
Trimming	64
Troubleshooting	105
TV	86
Twilight mode	48
Twilight Portrait mode	48

U

Underexposure	12
USB adaptor for Multi connector	96
USB cable	96
USB Connect	80
Using your camera abroad	120

V

VGA	15
Video Out	80
View Images	44
Viewing images	35
Viewing menu	61
Vivid	54
Volume	35
Volume Settings	71

W

Warning indicators and messages	116
White Balance	53
Windows computer	90
Recommended environment	91

Z

Zoom	28, 36
------------	--------

Notes on the License

“C Library”, “Expat” and “zlib”, software are provided in the camera. We provide this software based on license agreements with their owners of copyright. Based on requests by the owners of copyright of these software applications, we have an obligation to inform you of the following. Please read the following sections.

Read “license1.pdf” in the “License” folder on the CD-ROM. You will find licenses (in English) of “C Library”, “Expat” and “zlib” software.

On GNU GPL/LGPL applied software

The software that is eligible for the following GNU General Public License (hereinafter referred to as “GPL”) or GNU Lesser General Public License (hereinafter referred to as “LGPL”) are included in the camera.

This informs you that you have a right to have access to, modify, and redistribute source code for these software programs under the conditions of the supplied GPL/LGPL.

Source code is provided on the web. Use the following URL to download it.

<http://www.sony.net/Products/Linux/>

We would prefer you do not contact us about the contents of source code.

Read “license2.pdf” in the “License” folder on the CD-ROM. You will find licenses (in English) of “GPL”, and “LGPL” software.

To view the PDF, Adobe Reader is needed. If it is not installed on your computer, you can download it from the Adobe Systems web page:

<http://www.adobe.com/>

Additional information on this product and answers to frequently asked questions can be found at our Customer Support Website.

<http://www.sony.net/>