



CASSIOPEIA
FIVA



FIVA

User's Guide

(Product No.: MPC-205E/206E)

FIVA

Thank you for purchasing the CASIO MPC-205E/206E.
This guide describes the basic operations of the
MPC-205E/206E.

Read this guide in its entirety before handling or
operating this products, and keep it close at hand so
it can easily referenced.

CASIO®

International ENERGY STAR® Program

As a member of the International ENERGY STAR® Program, CASIO products have been judged to meet International ENERGY STAR® standards.

ENERGY STAR® is a U.S. registered mark.



The information regarding International ENERGY STAR® Program attached to this product and found in its manual, advertising pamphlets, and so on, is applicable under our Power Management software in Windows Me. When booting from B mode, it is not applicable.

Power Plug and AC Adaptor



AC cord plug and wall outlet illustrated in this User's Guide shows the two-pin plug type. It may not be the same shape of AC cord plug used in your area.

FIVA's AC adaptor has an automatic voltage switching circuit (input: 100 to 240VAC, 50/60Hz) and lets you use your FIVA under AC power virtually anywhere in the world without having an extra power-transformer. Note, however, that AC cord plug shape differ according to area you are in. Make sure that the AC cord you will use can fit into wall outlet and is compliance with the local electric safety standard.

-
- Microsoft, Windows are registered trademarks of Microsoft Corporation in the United States and/or other countries.
 - Other company, product and service names used herein may also be trademarks or service marks of respective companies.

Packing List

Thank you for purchasing the CASSIOPEIA FIVA205E/206E series. A list of the items included with this product is given below. Confirm that nothing is missing or damaged. If anything is missing or damaged, contact the dealer from which you purchased this product.

FIVA main unit

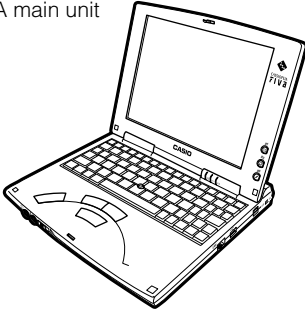

For CF card
Puller tapes (5)

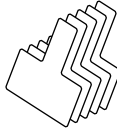

ID sticker

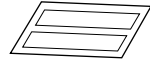

User's Guide

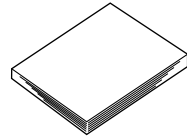

Stick caps (2)



AC adaptor

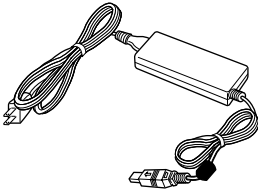

Battery pack

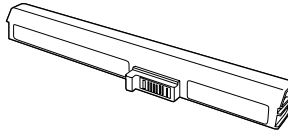

RGB cable

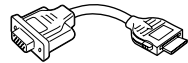

Windows Me
Quick Start Guide



Product
Recovery CD-ROM



Modular cable

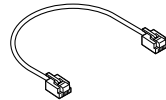

- Do not dispose of the box and packing materials. Use the box and packing materials for storage and transport.

Safety Precautions

- To use this product safely and correctly, read this User's Guide thoroughly and operate as instructed.
After reading this guide, keep it close at hand for easy reference.
- Always observe the warnings and cautions indicated on the product.
- If this guide is misplaced or damaged so as to be unreadable, a new one can be ordered. To obtain a new User's Guide, contact the dealer from which this product was purchased.

About the icons

In this guide various icons are used to highlight safe operation of this product and to prevent injury to the operator and other personnel and also to prevent damage to property and this product. The icons and definitions are given below.

 **Warning!** Indicates that there is a risk of severe injury or death if used incorrectly.

 **Caution!** Indicates that injury or damage may result if used incorrectly.

Icon examples

To bring attention to risks and possible damage, the following types of icons are used.



The  symbol indicates that it includes some symbol for attracting attention (including warning). In this triangle the actual type of precautions to be taken (electric shock, in this case) is indicated.



The  symbol indicates a prohibited action. In this symbol the actual type of prohibited actions (disassembly, in this case) will be indicated.



The  symbol indicates that a restriction. In this symbol the type of actual restriction (removal of the power plug from an outlet, in this case) is indicated.



Warning!

Handling FIVA

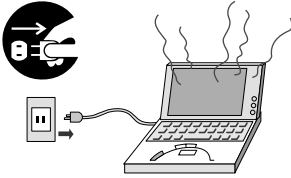

Should FIVA malfunction, start to emit smoke or a strange odor, or otherwise behave abnormally, immediately shut down the power, remove batteries, and unplug the AC adaptor from the power outlet. Continued use creates the danger of fire and electric shock.

- Contact your original retailer or authorized distributor.

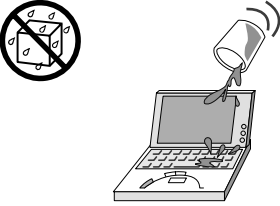

Do not place containers of liquids near FIVA and do not allow any foreign matter to get into it. Should water or other foreign matter get into FIVA, immediately shut down the power and unplug the AC adaptor from the power outlet. Continued use creates the danger of shorting, fire and electric shock.

- Contact your original retailer or authorized distributor.



Never bring in FIVA a bathroom or any other location where the possibility of splashing or high humidity exists. Use of FIVA in such an area creates the danger of electric shock. Be especially carefully when using FIVA while rain or snow is falling, or in beach areas.

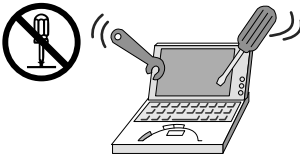

Never try to take FIVA apart or modify it in any way. High-voltage components inside FIVA create the danger of fire and electric shock.

- Contact your authorized distributor for all repair and maintenance.



Should you drop FIVA and damage it, immediately shut down the power and unplug the AC adaptor from the power outlet. Continued use creates the danger of shorting, fire and electric shock.

- Attempting to repair FIVA yourself is extremely dangerous. Contact your authorized distributor for all repair and maintenance.

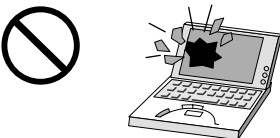

The liquid inside the LCD is harmful to humans. Never touch it or allow it to get in your mouth.

- Should liquid from the LCD panel accidentally get into your mouth immediately wash out your mouth with clean water. If it gets onto your skin, immediately rinse for at least 15 minutes with clean tap water. In either case, consult a physician.

⚠ Warning!

Power Plug and AC Adaptor



AC cord plug and wall outlet illustrated in this User's Guide shows the two-pin plug type. It may not be the same shape of AC cord plug used in your area.

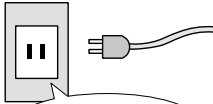

AC100~240V

Use only a proper AC electric outlet (100V~240V) when powering FIVA with the AC adaptor. Use of an outlet with a different voltage from the rating creates the danger of malfunction, fire, and electric shock. Overloading an electric outlet creates the danger of overheating and fire.

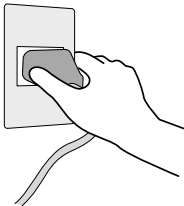

Make sure the power plug and AC adaptor plug are inserted as far as they will go. Loose plugs create the danger of electric shock, overheating, and fire.

- Do not use the adaptor if the plug is damaged. Never connect to a power outlet that is loose.

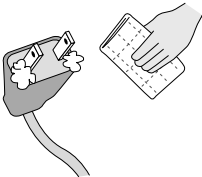

Use a dry cloth to periodically wipe off any dust built up on the prongs of the plug. Humidity can cause poor insulation and create the danger of electric shock and fire if dust stays on the prongs.

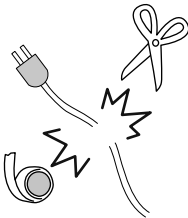

Do not allow the power cord or plug to become damaged, and never try to modify them in any way. Continued use of a damaged power cord can cause deterioration of the insulation, exposure of internal wiring, and shorting, which creates the danger of electric shock and fire.

- Contact your authorized distributor whenever the power cord or plug requires repair or maintenance.

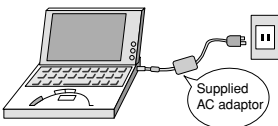

Use only the AC adaptor that comes with FIVA or the one specified by CASIO. Use of another type of AC adaptor creates the danger of fire.

Warning!

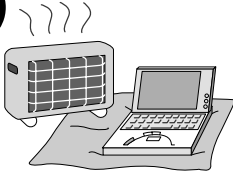

Do not cover the AC adaptor with a blanket, etc., or do not place FIVA on the heating rug, near a heater, etc. Doing so may cause malfunction or deformation of FIVA, which creates the danger of fire.

Battery Pack

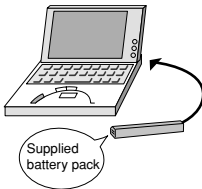

Use only the battery pack that comes with FIVA. When the battery pack reaches the end of its life, replace it with a new battery pack as specified by CASIO. Other types of batteries have different voltage rating and polarity, which creates the danger of fire and bursting of the batteries.

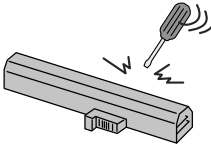

Never try to take the battery pack apart or modify it in any way. Doing so creates the danger of overheating, fire, and bursting of the battery pack.

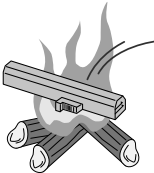

Never throw the battery pack into fire or otherwise expose it to direct flame. Doing so creates the danger of fire and explosion.

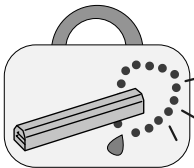

Never allow the positive (+) and negative (-) poles of the batteries to become connected by metal. Do not store or transport the battery pack together with metal necklaces, hairpins, or other metal items. Shorting of the battery pack poles creates the danger of overheating, fire, and explosion.

- When transporting or storing the battery pack, wrap it in plastic to keep the poles away from metal items that might cause a short.



Caution!

Handling FIVA

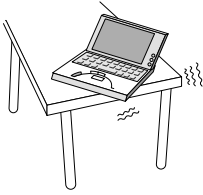

Do not place FIVA on an unstable or uneven surface. Doing so can cause FIVA to fall, creating the danger of malfunction, fire, and electric shock.

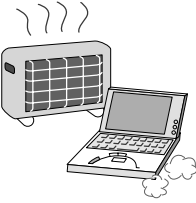

Do not leave FIVA in the following areas.

- Areas where FIVA will be subject to large amounts of humidity or dust, or directly exposed to hot or cold air.
- Areas exposed to direct sunlight, in a close motor vehicle, or any other area subject to very high temperatures.

The above conditions can cause malfunction or deformation of FIVA, which creates the danger of fire.

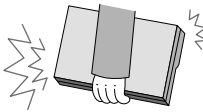

When transporting FIVA, take care to avoid subjecting it to vibration and impact. This unit contains a hard disk and other precision components that can be damaged by rough handling.

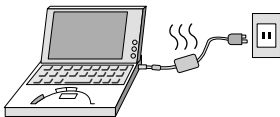

The AC adaptor normally becomes warm during use. Avoid allowing the AC adaptor to rest on your lap or other part of your body when using it for long period. Long term with the AC adaptor creates the danger of burns.

⚠ Caution!

Power Cord and Peripherals

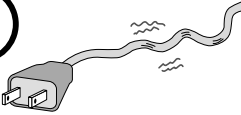

Do not overly bend the power cord, do not allow it to be caught between desks or other furniture, and never place heavy objects on top of the power cord. Doing so can cause shorting or breaking of the power cord, creating the danger of fire and electric shock.

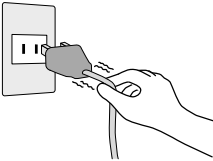

Be sure to grasp the plug when unplugging the power cord from the wall outlet. Pulling on the cord can damage it, break the wiring, or cause short, creating the danger of fire and electric shock.

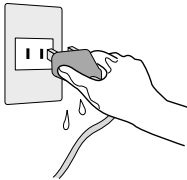

Never touch the plug while your hands are wet. Doing so creates the danger of electric shock. Pulling on the cord can damage it, break the wiring, or cause short, creating the danger of fire and electric shock.



When using headphones, make sure you do not turn up the volume too high. Doing so can cause hearing damage.



Avoid use in areas where the brightness around the display is very different from surrounding lighting, or where the sunlight is shining directly on the display. Such conditions can cause eye fatigue.

Before Using FIVA

- This product has been designed and manufactured under stringent quality control. Should you suspect FIVA is defective or malfunctioning, contact your original dealer or authorized distributor. Repair and maintenance are subject to the terms and conditions of the Warranty. The mis-operation of electronic product may create a risk of injury caused by a fire or electric shock, etc. To avoid the accident, be sure to follow the instructions below.
 - **Follow the cautions**
The cautions for FIVA are described on [pages from 2 to 7](#).
 - **Do not use FIVA if it does not work correctly**
Contact your original retailer or authorized distributor.
 - **If FIVA works abnormally**
If FIVA malfunctions, or emits smoke, strange odor or noise, etc., immediately shut down the power, remove the battery pack, and unplug the power cord of the AC adaptor from the power outlet. Contact your original retailer or authorized distributor.
- CASIO COMPUTER CO., LTD. shall not be held liable for any loss or claims due to using this product except as instructed to do so in this User's Guide.
- CASIO COMPUTER CO., LTD. shall not be held liable for any loss or claims (lost profits, interruption of business, corruption or loss of memory data, etc.) by you or any third party due to the use of this product or the inability to use this product for a specific purpose, except as specifically stipulated by law.
- Unauthorized copying of this product or its software is prohibited.
- This product is guaranteed only when operating under the version of Windows Me that comes bundled with it.
- This product is guaranteed only when operating under the version of Windows Me that comes bundled with it.

Product Application

- This product is intended for use as a general office computing device.
- CASIO makes no warranties, that this product is fault-tolerant. It is not designed, manufactured or intended for use in which the failure of FIVA could lead directly to death, personal injury, or severe physical or environmental damage.

System Recovery

- This product comes with Windows Me and a collection of utility software pre-installed on its hard disk. Should the problem occur to the system or applications due to an unexpected malfunction, you can use the “Product Recovery CD-ROM” that comes with FIVA to restore the factory default system. This returns FIVA the same settings and state it was in when you originally purchased it.

Computer Viruses

Avoiding Computer Viruses

A computer virus is a program. It gets installed on your system without you being aware of it, and can do anything from displaying strange messages to destroying your data and other programs. A virus can enter your system via a floppy diskette or network. Taking the following precautions are normally sufficient to protect against having a virus invade your system.

- Write protect the master copies of your programs and data files.
- Never open data files or run programs of unknown origin.
- Use a commercially available virus checker to check new programs, and periodically check your system for virus contamination.

Use the latest version of a commercially available virus checker to check your system.

An immediate virus check is recommended in the following cases.

- Check your system each time you start up your computer.
- Check any data file or program you received on a floppy diskette or other external media, over a network, from a BBS or the Internet, via e-mail, etc. before opening the file or running the program.

FIVA

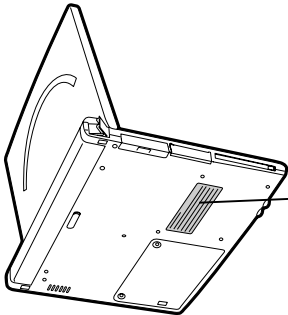

Caution

- **Turn off this product before connecting or disconnecting peripherals.**
- **Never apply impact or vibration.**
- **Never take this product apart.**
- **Use only the specified AC adaptor.**
- **The bottom of this product becomes warm during use. Avoid using it on your lap for a long period.**

Precaution Label

- The label shown above is affixed to the bottom of FIVA.
Be sure to carefully observe these precautions at all times. Never remove this label.
Should this label ever start to come off or should its contents become unreadable, contact your original dealer or authorized distributor.

Power Requirements

- Plug the AC adaptor into a power outlet rated for 100V to 240V AC, 50/60Hz only.
- Do not connect FIVA to the same outlet of another device that generates electrical noise. Such a device can corrupt data in FIVA.

Turning Off Power

- Never shut down the power while the system startup routine is being executed or while a program is running. Doing so can cause data to be lost or corrupted, causing malfunction of FIVA.
- Do not turn power on and then suddenly off again. Doing so can cause data to be lost or corrupted, causing malfunction of FIVA.

Cables

- Use only the cables that come with FIVA or the one specified by CASIO to connect it to other optional equipment.
- Never pull on cable or place heavy object on it. Doing so can cause the cable to break or short.

The bottom of FIVA or the AC adaptor becomes warm during use

- This is caused by the CPU operation or the current when FIVA's battery is charged. This is not malfunction. The heating value changes according to the condition of use.
- When FIVA or the AC adaptor is warmer than usual, shut down the power, unplug the power cord of the AC adaptor and remove the battery pack.
Contact your original retailer or authorized distributor.

Avoid Strong Vibration and Impact

- Strong vibration or impact can cause malfunction. Be particularly careful when FIVA is turned on. Vibration and impact can cause corruption of data on built-in hard disk.

Avoid Water and Moisture

- FIVA is not water resistant. Never use or store FIVA where there is the danger it might become exposed to water or moisture.

Transporting FIVA

- Be sure to shut down the power and disconnect all options (FD drive, CD-ROM drive, etc.) before removing FIVA. Leaving cables connected while removing FIVA can damage the cables and creates the danger of accident.

Options

- Be sure to carefully follow the procedures provided in the applicable User's Guides whenever connecting or disconnecting peripherals. Failure to do so can damage FIVA or the peripheral.

AC adaptor: WARNING

- Use the AC adaptor MPC-277ADPE.

Main battery: WARNING

- Replace this main battery with the MPC-273BAT or MPC-274LBAT. Use of other battery may present a risk of fire or explosion.
- This battery pack is suitable for use only with the MPC-205E or MPC-206E.
- Dispose of used batteries according to the manufacturer's instruction.

Non-CASIO options

- Check with the manufacturer for compatibility before using any non-CASIO options with this unit.
- CASIO assumes no responsibility for any loss (including but not limited to personal injury, material loss, damage to FIVA) suffered by you or other arising out of the use of a non-CASIO option.

Hard Disk Data

Disk Operations

- A lit hard disk drive access lamp indicates that a disk operation is being performed.
- Never shut down while a hard disk drive is being performed. Doing so can make data or applications on the disk unusable.

Backup Data

- You should occasionally back up data on the hard disk by copying it to floppy diskette. This ensures that you always have backup data on hand in case of accidental data deletion or corruption caused by mis-operation, malfunction, maintenance, etc.

Note that CASIO is not liable for any losses suffered by you or any third party due to the loss of data stored on FIVA's hard disk.

Consumables

Standard Battery Pack

- Long use of the battery pack causes it to deteriorate and lose its ability to recharge. If you feel your battery pack is not providing enough operating time, it may be time to contact your dealer or authorized distributor about purchasing a new one.

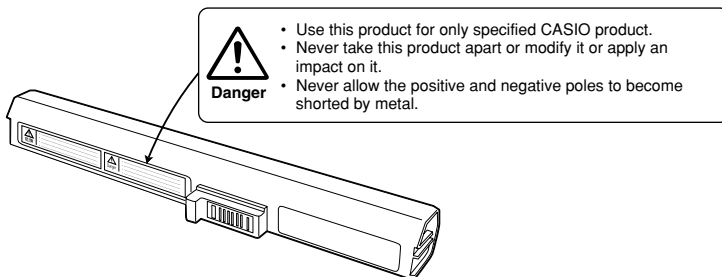

Disposal

When it comes time to dispose of your FIVA, do so in accordance with local regulations in your area. Contact your local government authorities for details about proper disposal methods.

Maintenance and Care

Normal Care



Shut down the power and unplug the power cord from the power outlet before cleaning FIVA. Cleaning FIVA with the power on creates the danger of electric shock.

- Clean FIVA by wiping it with a soft, dry cloth. If FIVA is very dirty, wipe it with a cloth that has been moistened with a weak solution of water and a mild neutral detergent. Wring out all excess moisture before wiping.
- Clean the LCD by wiping it with a soft, dry cloth. Never use water, detergent, or chemical agents to clean the LCD. The surface of the LCD is easily scratched. Never apply excess pressure when wiping it.
- Thinner, benzene, or other organic agents can cause deformation or discoloration of FIVA's case, and even malfunction of FIVA. Never use such agents when cleaning FIVA.

Maintenance



Never remove FIVA'S outer cover or otherwise try to take it a part or modify it in anyway. High voltage inside the case creates the danger of electric shock.

Whenever you notice any of the following symptoms, immediately shut down the power, unplug the AC adaptor from the power outlet, and contact your original dealer or authorized distributor.

- Damaged power cord or plug
- Liquid leaking from FIVA
- Exposure of FIVA to water or rain
- Unit being dropped
- Damaged unit cover
- Very abnormal function
- Abnormal operation

Never try to make any adjustments except as specifically instructed by this User's Guide. Improper adjustment or modification of FIVA can permanently damage it and make it impossible to restore normal operation.

Never attempt to repair or modify this unit in any way.

The CE marking below applies to the EU region. Declarator of conformity is as follows:



CASIO ELECTRONICS CO. LTD.

Unit 6, 1000 North Circular Road, London NW2 7JD

GUIDELINES LAID DOWN BY FCC RULES FOR USE OF THIS UNIT IN THE U.S.A. (not applicable to other areas).

NOTICE

This equipment has been tested and found to comply with the limits for a Class B digital device, pursuant to Part 15 of the FCC Rules. These limits are designed to provide reasonable protection against harmful interference in a residential installation. This equipment generates, uses and can radiate radio frequency energy and, if not installed and used in accordance with the instructions, may cause harmful interference to radio communications. However, there is no guarantee that interference will not occur in a particular installation. If this equipment does cause harmful interference to radio or television reception, which can be determined by turning the equipment off and on, the user is encouraged to try to correct the interference by one or more of the following measures:

- Reorient or relocate the receiving antenna.
- Increase the separation between the equipment and receiver.
- Connect the equipment into an outlet on a circuit different from that to which the receiver is connected.
- Consult the dealer or an experienced radio/TV technician for help.

FCC WARNING

Changes or modifications not expressly approved by the party responsible for compliance could void the user's authority to operate the equipment.

Declaration of Conformity

Model Number:	MPC-205E and MPC-206E.
Trade Name:	CASIO
Responsible party:	CASIO INC.
Address:	570 Mt. Pleasant Avenue, Dover, New Jersey 07801.
Telephone number:	973.361.5400

This device complies with Part 15 of the FCC Rules. Operation is subject to the following two conditions: (1) This device may not cause harmful interference, and (2) this device must accept any interference received, including interference that may cause undesired operation.

Industry Canada

"This digital apparatus does not exceed the Class B limits for radio noise emissions from digital apparatus as set out in the interference-causing equipment standard entitled "Digital Apparatus", ICES-003 of the Department of Communications.

Industrie Canada

"Cet appareil numérique respecte les limites de bruits radioélectriques applicables aux appareils numériques de Classe B prescrites dans la norme sur le matériel brouilleur : "Appareils Numériques", NMB-003 édictée par le ministre des Communications."

Contents

Packing List	1
Safety Precautions	2
Before Using FIVA	8
Maintenance and Care	13
Normal Care	13
Maintenance	13
About This User's Guide	18
Chapter 1 Getting Ready	19
Part Names and Their Functions	21
Opening FIVA	21
Front	22
Back	24
Keyboard	26
Key Combinations	28
NumLock Keypad	29
Control Buttons and Stick	30
Changing a stick cap	32
Before Using FIVA for the First Time	33
Setting and Removing the Battery Pack	33
Charging the Battery Pack	34
Chapter 2 Using FIVA	37
Turning on Power the First Time	39
Performing the Windows Me Setup	39
Shutting Down the Power	45
Using the Sleep function	50
Turning On Power	51
Using the Battery Pack	52
Checking the Current Charge Level of the Battery Pack	52
Using the Battery Pack Efficiently	54
Using the Large-capacity Battery Pack	55
Using the One Touch Operation Buttons	56

1

2

3

Appendix

Chapter 3 Supplementary Information 59

Connecting Peripherals	61
Connecting a pair of Headphones or a Microphone	61
Connecting to the LAN port	62
Connecting to the modem port	63
Connecting to the USB port 	64
Using External Monitor	67
Connecting to the IEEE1394 port	69
Using a PC Card	70
Using a PC Card	70
Using a CF Card	73
Using a CF Card	73
Loading an Expansion Memory	76
Using the “Mobile Cockpit II”	80
① Switching the tool bar	81
Registering applications in the “Launcher bar”	81
② Panel	84
Changing the display position of the tool bar	84
Pop-up menu	85
③ Settings	86
One Touch Operation Button Setting	86
Wake On Timer Setting	87
Power Management Setting	87
Settings (Preferences)	90
④ Power management	91
⑤ Brightness control	92
⑥ Stop functioning of the hard disk	92
⑦ Adjusting the volume	92
⑧ PC card properties	93
⑨ Long-Run setting	94
⑩ Battery Control	95
⑪ Battery indicator	96
⑫ Standby Mode	96
⑬ Hibernation Mode	96

Appendix	97
System Restoration	99
Starting up from the “Product Recovery CD-ROM”	100
Setting the Partition of Hard Disk/Initializing the Hard Disk	101
Making Windows Me Settings	111
Installing applications from the “Product Recovery CD-ROM”	116
Installing the CASIO Applications	116
Making Screen Settings	118
Installing Microsoft Me Components	119
Making a Startup Disk	121
Using the Terminal Equipment FB1456VQL12	122
For users in the United States	122
Notice Concerning FCC Radial Regulations	124
For users in Canada	125
Main functions of the modem	126
Connecting to telephone line	127
Connecting to the FIVA	128
Caution on operation of the product	128
Troubleshooting	129
Basic Troubleshooting	129
System Outline	130
Memo about your system	130
Power Supply	131
Display Problems	132
Software Problems	133
Peripheral Operation Problems	134
Text Input Problems	135
Printing Problems	135
General Operation Problems	136
Problems Following Restoration of the System	138
FIVA Malfunction	138
Specifications	139
Options List	141

About This User's Guide

This User's Guide is divided into the five sections shown below. Be sure you read the section titled "Before Using FIVA" starting from [page 8](#) before you do anything else.

Before Using FIVA

This section provides important safety precautions and things you need to know about use of FIVA correctly.

Chapter 1 Getting Ready

This chapter provides you with general description of functions and part names, and other information you need to know before trying to use FIVA.

Chapter 2 Using FIVA

This chapter covers such operations as turning on power, setting up Windows Me, and other operational procedures.

Chapter 3 Supplementary Information

This chapter contains information about how to connect peripherals and about convenient functions.

Appendix When you run into trouble

This appendix tells you how to solve the problem and how to restore FIVA to the default settings.



: This mark indicates important cautions and things to which you need to pay attention when you operate FIVA.



: This mark indicates that you need to memorize.

Windows Me means Microsoft Windows Millennium edition operating system. This User's Guide described it as Windows Me.

Getting Ready



Chapter 1

This chapter provides you with general description of functions and part names, and other information you need to know before trying to use FIVA.

Part Names and Their Functions

The part names introduced in this chapter are used throughout the rest of this User's Guide. CASSIOPEIA FIVA has the port and the slot for PC card in order to connect to peripherals such as a network, the USB equipment, etc. As the part names are described in this User's Guide many times, remember these names introduced in this chapter. At first, open the display panel.





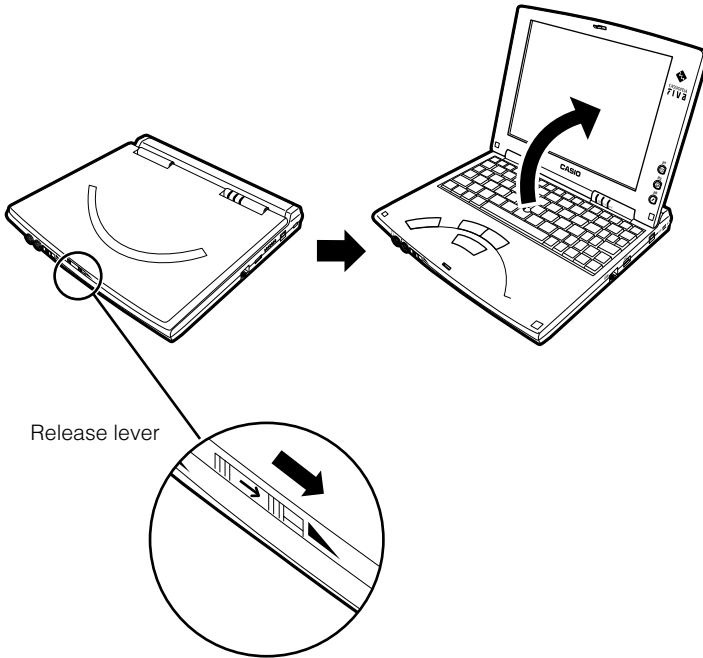



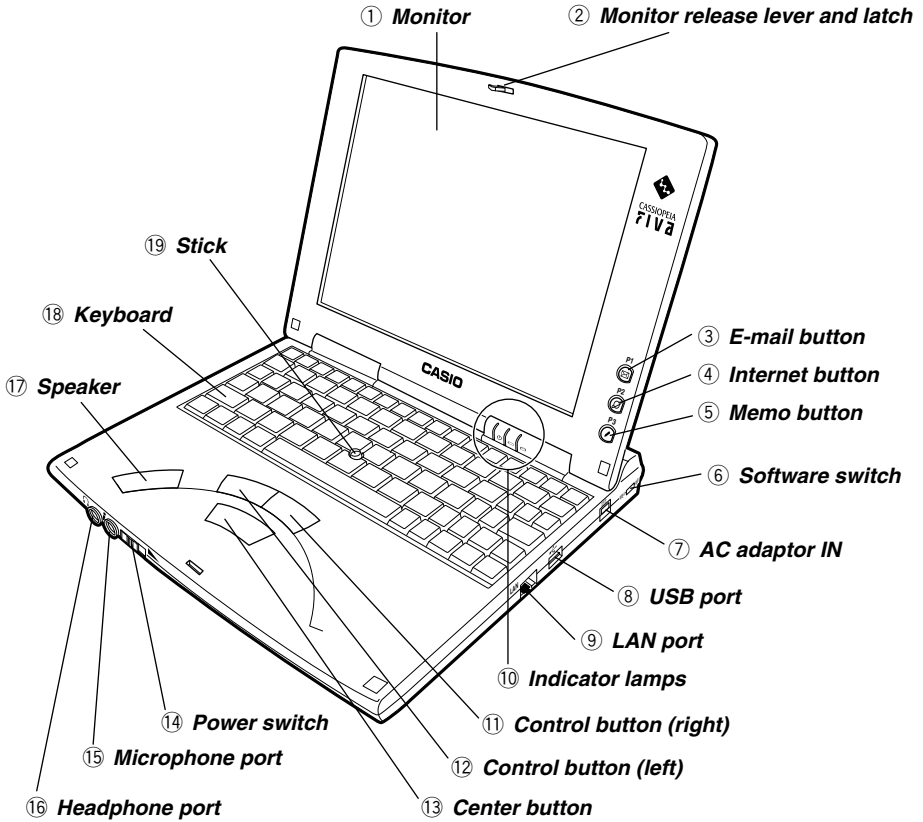

Opening FIVA

Slide the monitor release lever in the direction of the arrow and open the display panel.





Front

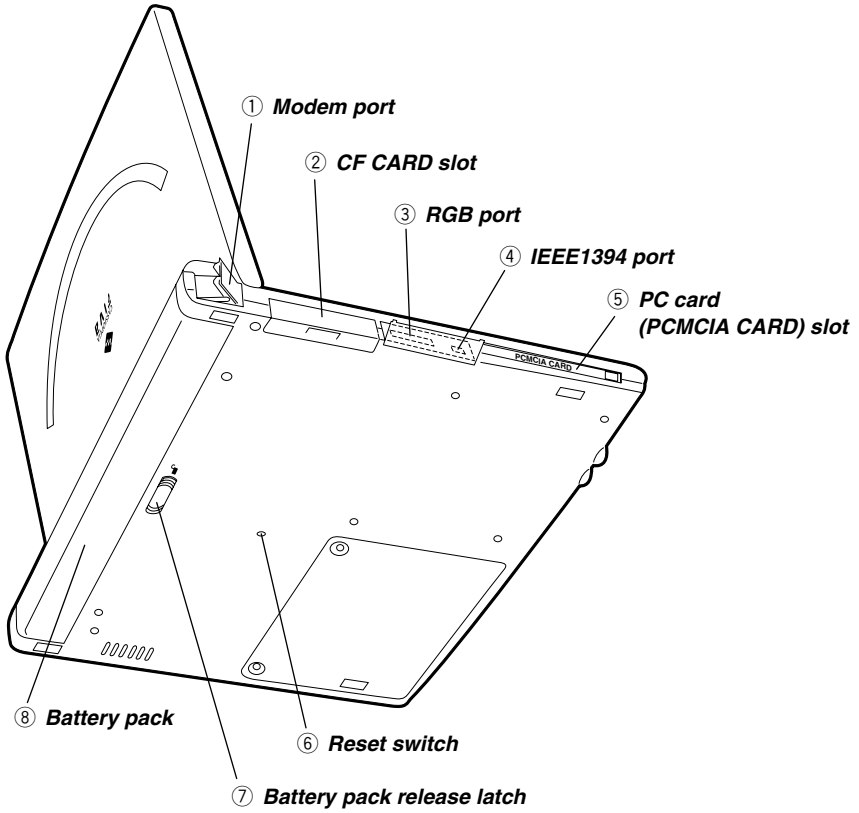

- ① **Monitor**
8.6-inch color TFT LCD (SVGA)
- ② **Monitor release lever () and latch**
Slide this lever to the right to open the monitor.
You can close the monitor securely using the latch.
- ③ **E-mail button ()**
Press this button to start up the E-mail software.
- ④ **Internet button ()**
Press this button to start up the Internet Browser.
- ⑤ **Memo button ()**
Press this button to start up the Note pad software.
- ⑥ **Software switch (MODE A ↔ B)**
Slide this switch to select the start-up mode.
If you start up FIVA in MODE B, the Linux system will be in function. However, you can use only the applications (MP3 player and FTP client) available for Linux.
- ⑦ **AC adaptor IN port (DC IN 16V)**
Connect the AC adaptor to this port.
- ⑧ **USB port ()**
Connect a peripheral to this port.
- ⑨ **LAN port (LAN)**
Connect the Ethernet to this port.
- ⑩ **Indicator lamps**
PW (): Power indicator lamp ([page 53](#))
BAT (): Battery pack status indicator lamp ([page 35](#))
HDD (): Hard disk access indicator lamp (The indicator lights green when the hard disk is in function.)
- ⑪ **Control button (right)**
This button functions like the mouse right button.
- ⑫ **Control button (left)**
This button functions like the mouse left button.
- ⑬ **Center button**
Move the stick ⑲ on the keyboard while holding down this button to scroll the display.
- ⑭ **Power switch ()**
Slide this switch to the right to turn ON and OFF the power of the unit.
- ⑮ **Microphone port ()**
Connect a commercially available microphone to this port.
- ⑯ **Headphone port ()**
Connect a pair of commercially available headphones or a speaker to this port.
- ⑰ **Speaker**
- ⑱ **Keyboard**
- ⑲ **Stick**
Operating this stick moves the pointer.

Back



- ① **Modem port**
Plug the modular cable into this port to connect the telephone line via the built-in modem.
- ② **CF CARD slot (CF CARD)**
Insert a CF card into this slot.
- ③ **RGB port (RGB)**
Connect an external monitor using the supplied RGB cable.
- ④ **IEEE1394 port (1394)**
Connect a digital equipment, e.g., digital video camera to this port.
- ⑤ **PC card slot (PCMCIA CARD)**
Insert a PC card into this slot.
- ⑥ **Reset switch**
Press this switch with a thin, pointed object to forcibly turn off the unit. Use this switch only when experiencing operational problems.
- ⑦ **Battery pack release latch ()**
Slide the latch to remove the battery pack.
- ⑧ **Battery pack**
Install the removable battery pack.

Keyboard

This section describes the basic functions of the keyboard. Actual keyboard functions may differ in accordance with the application you are using.

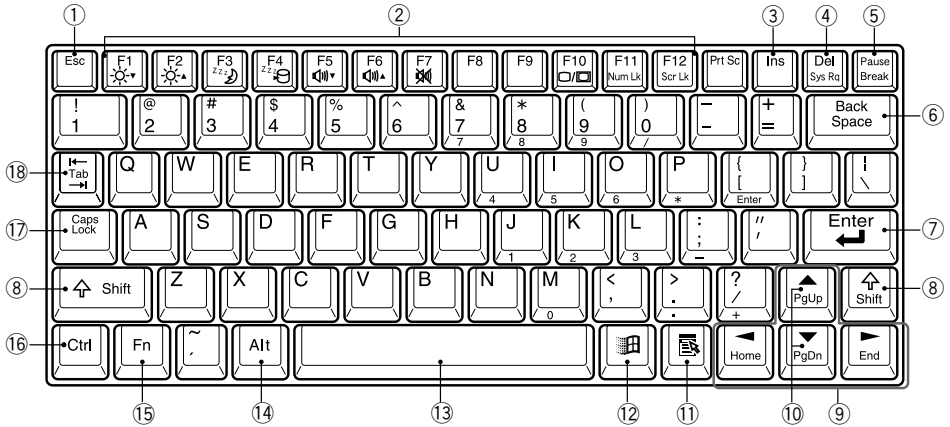











The above keyboard layout shows the US version.





















No.	Key	Key Name	Description
①		Escape	Cancels an operation.
②		Function	Execute specific functions.
③		Insert	Toggles character insertion on and off.
④		Delete	Deletes the character to the right of the cursor.
⑤		Pause	Pauses a process.
⑥		Backspace	Deletes the character to the left of the cursor.
⑦		Enter (Return)	Enters data or inserts a carriage return.
⑧		Shift	Shifts the keyboard between upper case and lower case.
⑨		Cursor	Moves the cursor on the screen.
⑩		Page Up, Page Down	Pressing these keys after the  key scrolls the screen one page up or down.
⑪		Application	Performs a mouse right button click operation (context menu display).
⑫		Windows	Displays the Windows Me Start menu.
⑬		Space	Inputs a blank space.
⑭		Alternate	Used in combination with other keys to perform operations and execute commands.
⑮		Fn	Activates certain "hot keys" functions.
⑯		Control	Used in combination with other keys to perform operations and execute commands.
⑰		Caps Lock	Pressing this key while holding down shift locks the keyboard in upper-case input.
⑱		Tab	Inputs a tab operation.

Key Combinations









- Key combinations where you must hold down one key and press a second key are indicated by a plus symbol.

 + 	This key operation shift locks the keyboard for upper-case character input. Perform this operation again to unshift the keyboard.
 +  + 	Restarts the system without turning off power.
 + 	Places a displayed image of the entire screen onto the clipboard.
 +  + 	Places a displayed image of the active window onto the clipboard.

- The following shows the key combinations that are available with the  key.

 + 	Displays the Run dialog.
 + 	Iconizes all windows.
 +  + 	Expands all icons to windows.
 + 	Displays online help.
 + 	Starts up Windows Explorer.
 + 	Displays the file or folder search screen.
 +  + 	Displays the computer search screen.
 + 	Sequentially selects the buttons on the Taskbar.
 + 	Displays System Properties.

- The following shows the key combinations that are available with the **Fn** key. This is called the “hot keys” function.

Fn + F1 ☀️ F2	Increases or decreases LCD brightness.
Fn + F3 	Puts FIVA into Standby Mode . (Pages 47, 96)
Fn + F4 	Puts FIVA into Hibernation Mode . (Pages 48, 96)
Fn + F5 🔊 F6	Increases or decreases speaker sound volume.
Fn + F7 	Stops speaker sound.
Fn + F10 	Cycles through monitor function in the following sequence: LCD(FIVA) → CRT* → CRT* and LCD(FIVA) → LCD(FIVA).
Fn + F11	The keyboard enters the NumLock mode and the specific keys can be used as numeric keys (see next page for details).
Fn + F12	 ,  ,  and  keys can be used when scrolling the screen on some software.

*CRT = External monitor



- Some hot key combinations are not available while the system is starting up, or in **Standby Mode** or **Hibernation Mode**.
- Using hot key combinations during high-speed data communications can cause data communication errors.

NumLock Keypad

Holding down **Fn** and pressing **F11** activates NumLock, which assigns numeric keypad functions to the keyboard keys shown below. Press **Fn** + **F11** to cancel NumLock.



Control Buttons and Stick

FIVA has a stick, two control buttons and a center button to control the pointer (🖱).

- **Stick**
This can be used to control the pointer on the screen.
Put a finger on the stick and move it in every direction to control the pointer on the screen.
The pointer speed can be changed according to the force you press the stick.
When you press the stick strongly, the pointer speed becomes fast.
Pressing the stick straight is the same operation as pressing the left control button.
- **Control Buttons**
Move the pointer to the desired item and select it with the left or right control button.
The left and right control buttons function like the left and right buttons of the mouse respectively.
- **Center Button**
The part which is not displayed on the screen can be viewed by scrolling the display. While holding down this button, operate the stick in the direction of the part you want to view (available only for the software compatible with this function).

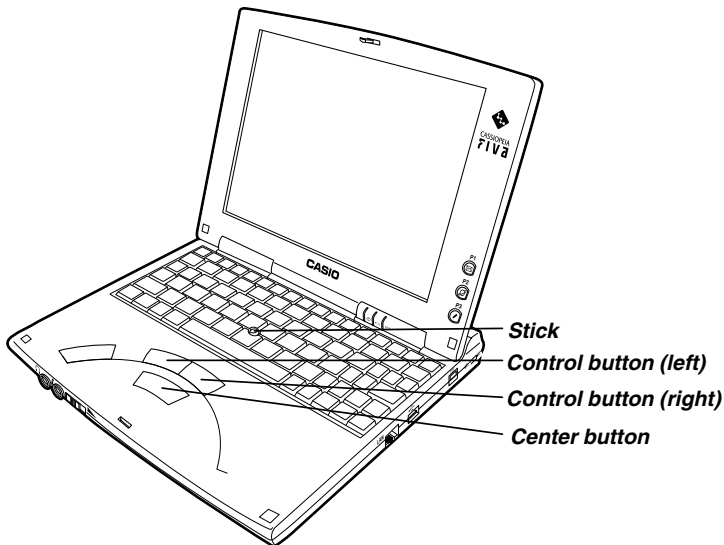



Important

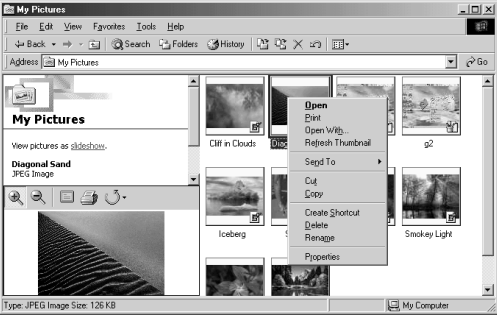

Do not touch the stick, buttons or keyboard with hands which have hand cream or oil on them. Doing so may cause fingers to slip while operating and intrusion of oil-based compounds into the unit may cause a malfunction such as input failure.

The following operations can be performed with the control buttons.

Function	Control Button Operation
Click	<p>Move the pointer to the desired position and press the left control button once.</p> <p>This button is used to select OK, Next, etc.</p>
Double-click	<p>Move the pointer to the desired position and press the left control button twice in succession.</p> <p>You can start up an application.</p>
Drag and drop	<p>While holding down the left control button, move the pointer with the stick.</p> <p>An object, e.g., icon, can be moved together with the pointer (drag). When you reach the location where you want to place the object, release the control button (drop).</p>
Click with the right control button	<p>When the right control button is pressed, the menu is displayed. The various menus are displayed in accordance with the item you clicked.</p> <p>Example 1) Press the right control button at the specified location.</p>  <p>Example 2) Press the right control button on the desk top.</p> 
Scroll	<p>While holding down the center button, operate the stick so that the scroll bar on the software is moved upward, downward, leftward and rightward.</p>

The setting of the pointer can be specified in the window setting menu opened by selecting **Control Panel** and double-clicking **Mouse**. The speed of the double-click or pointer can be adjusted.

Changing a stick cap

The stick cap is an expendable item. It can be replaced with a supplied new one when it is worn.

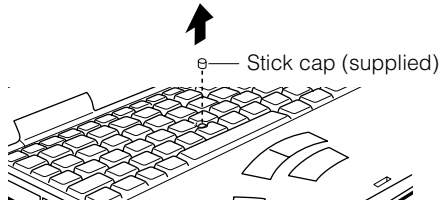

Important



Put the cap on the stick firmly. Otherwise, the cap may damage the LCD monitor when you close the display panel.

Before Using FIVA for the First Time

Though operation is possible using the AC adaptor only, it is a good idea to attach the battery pack and charge it before using FIVA for the first time.

Setting and Removing the Battery Pack

When you set the full-charged battery pack, you can use this unit without connecting the AC adaptor.

Make sure you correctly set the battery pack so it does not come off accidentally during unit operation. Set up and removal procedures are the same for both standard battery pack and large-capacity battery pack.

Important



The battery pack that comes with FIVA is not charged when you purchase it. Be sure to fully charge the battery pack before using it to power FIVA.



Use only the battery pack that comes with FIVA or a battery pack specified in this User's Guide. Use of other type of battery pack creates the danger of fire.

To set the battery pack

1. Close FIVA and turn it over.
2. Carefully slide the battery pack onto FIVA as shown in the illustration below until you hear it click securely into place. If you have trouble getting the battery pack to connect to FIVA, try sliding the battery pack release latch. Do not turn on FIVA yet.

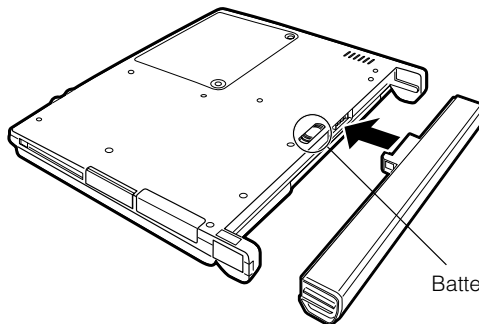

Make sure the battery pack is set securely to FIVA. Improper setting can cause the battery pack to fall off during transport.

To remove the battery pack

Before removing the battery pack, be sure to turn off the power. (When the AC adaptor is connected to FIVA and a power outlet, you can remove the battery pack without turning off the power.)

1. Close FIVA and turn it over.
2. While sliding the battery release latch in the direction indicated in the illustration below, pull the battery pack from FIVA.

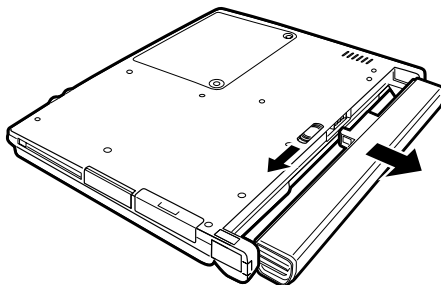

Make sure you have a firm grasp of the battery pack when you pull it from FIVA. Dropping the battery pack can cause it to fall on your foot or otherwise cause personal injury.



- If you remove the battery pack while the power of FIVA is turned on without connecting the AC adaptor, data may be erased. Also, if you remove the battery pack while FIVA is in Sleep Mode, data may be erased. To prevent data from erasing, be sure to connect the AC adaptor.

Charging the Battery Pack

The battery pack is fully charged in about 2.5 hours while the AC adaptor is connected and plugged into a power outlet, regardless of whether the FIVA is turned on or not.



1. Connect the AC adaptor to one end of the power cord (❶) and the other to the power outlet (❷).

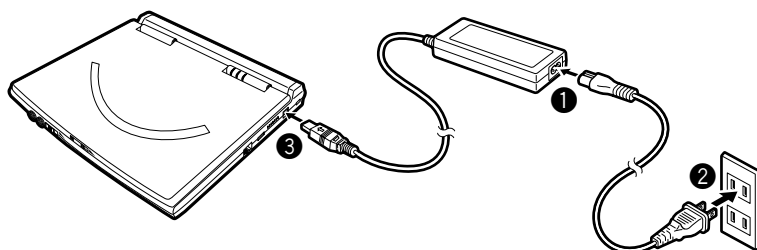

Use the AC adaptor that comes with this product or the one specified by the manufacturer. Otherwise, it may create the danger of fire arisen from emitting smoke or catching fire.

2. Connect the plug of the AC adaptor to the AC adaptor IN port (DC IN 16V) on the side panel of FIVA (3).



The BAT () indicator lights orange while the battery is being charged, and the indicator lights green when the battery is fully charged. If the BAT () indicator lamp goes out during charging, it means FIVA's internal protection circuitry has activated to cancel the charge operation. If this happens, try disconnecting the AC adaptor and battery from FIVA, and then resetting them. If this problem persists, it could indicate malfunction of the battery pack or FIVA. Contact your original retailer or authorized distributor.

Battery Indicator Lamp	Meaning
Green	Full charge
Orange	Charging
Off at start of charge	Charging is disabled. Try charging again in an area where temperature is within allowable range.
Off during charge	Charge was aborted. Remove battery pack from unit and check it for external abnormality.

When removing the AC adaptor from the AC adaptor IN port, hold the plug of the AC adaptor firmly and pull it out straight as shown below.

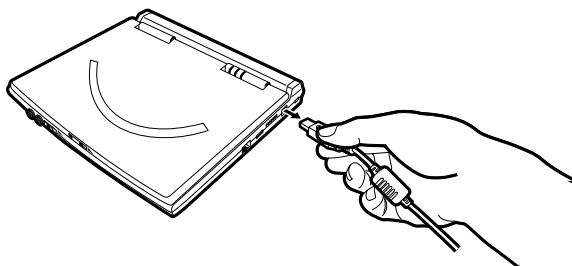

Do not pull the cord itself. Doing so may damage the cord and cause it to break or short circuit, creating the danger of a fire and electric shock.

**Note**

- If the battery pack is attached to FIVA, do not unplug the AC adaptor until the BAT (🔌) indicator lamp turns green (full charge). This helps to extend battery pack life.
- The battery pack requires period replacement. The end of a battery pack's service life is indicated when the battery pack powers FIVA for a relatively short period after a full charge. When this happens, replace the battery pack with a new one.
- [See page 52](#) for information about battery pack life and charging capacity.

Important

- Locate the AC adaptor power cord in a place where it will not be tripped over.
- Charge the battery pack in an area where the temperature is within the range of 5°C to 35°C (41°F to 95°F). The battery pack may fail to reach a full charge at temperatures outside this range. In this case the BAT (🔌) indicator lamp does not light.
- If the power cord is connected to a power outlet for a long time, the plug may become dusty. Clean the plug occasionally.

Using FIVA

A silver Casio laptop is shown from a three-quarter perspective, open. The screen displays a globe of the Earth. The laptop has 'CASIO' and 'CASSIOPEA FIVA' logos. A large, white, semi-transparent grid pattern is overlaid on the laptop, and the text 'Chapter 2' is centered over the globe.

Chapter 2

This chapter covers such operations as turning on power, setting up Windows Me, and other operational procedures.

Turning on Power the First Time

The first time you turn on the power, you must perform a Windows Me setup procedure. You need to perform this procedure only once. After that, Windows Me will boot up automatically when you turn on the power.

The Windows Me setup routine lets you make the settings listed below. The “Product Key” is sealed on the bottom of this unit. Have it on hand when performing the setup procedure for the first time.

Setting	Description
End-user License Agreement	Read and agree to the terms and conditions of the End-user License Agreement.
Product Key	Input the correct Windows Me Product Key number.

Performing the Windows Me Setup

When you turn on the power of this unit for the first time, perform the Windows Me setup procedure.

Important



Do not shut down the power once the Windows Me setup procedure starts. Also, be sure to power FIVA with its AC adaptor while performing the setup procedure.

1. Open up FIVA.
2. Slide the power switch () to the right.

Though it may take a few moments before anything appears on the display, you do not need to keep the power switch slid. Simply press it once and release it.

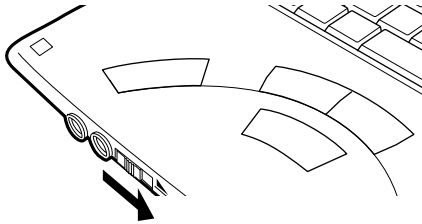

3. The message below appears after the “Windows Me” screen is shown. Click **Yes** immediately to restart FIVA.

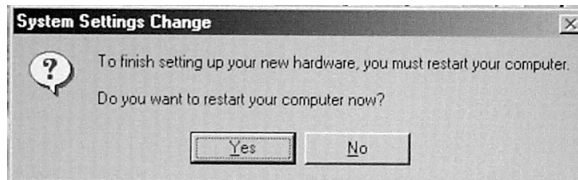

4. The CASIO logo appears for a few moments. And, the “Windows Me” screen appears.

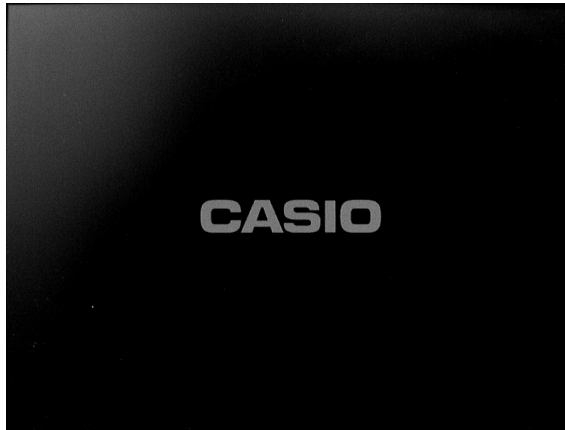

After the CASIO logo appears, the screen goes blank and then Windows Me starts up.

After that, “Welcome to Microsoft Windows” screen appears.

To use the Windows Me, follow the procedure below.

First, click **Next**.

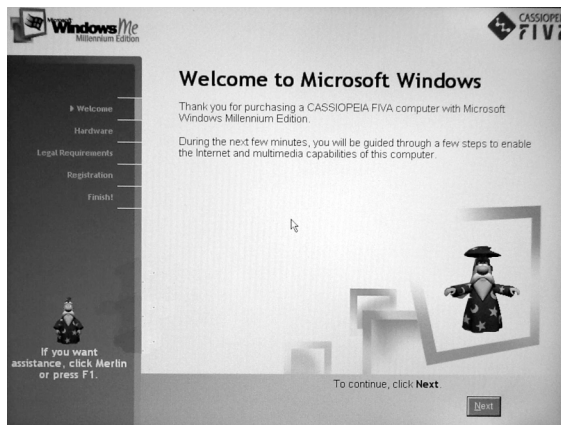

5. “Select your time zone” appears.
Select your local area and click **Next**.

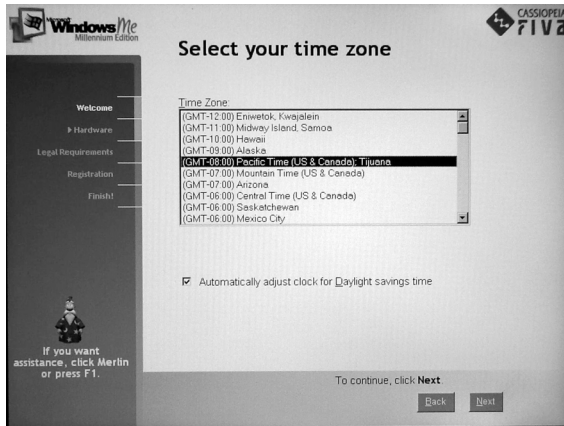

6. Read and agree to the Software License Agreement.
- Be sure you read the terms and conditions of the Microsoft Software End-user's License Agreement.
 - To read all, use the ▲ or ▼ button, or [PgUp] (Fn + ↑) or [PgDn] (Fn + ↓) button to scroll the screen.

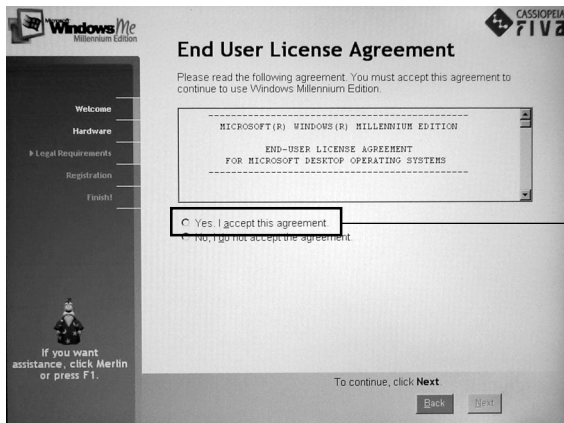

- Click the option button next to “Yes, I accept this agreement.”, and then click **Next**.

7. Input the Product Key number.

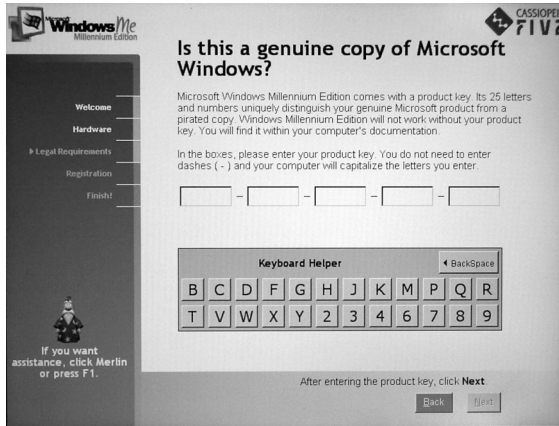

- Input the Product Key number that is printed on the Certificate of Authenticity affixed to the back of this unit, and then click **Next**. All the letters and numbers you type in this screen are automatically input in upper case, even if you do not press the **[Shift]** key.

Important



Make sure you input the Product Key number correctly. Take care that you distinguish between the letter O and the number 0 (zero).

- The message shown below appears if you do not input the correct Product Key number. Click the **OK** button and input the correct Product Key number.

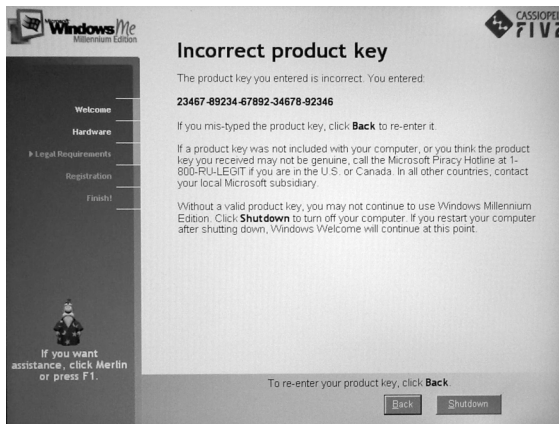

Note

Your Product Key number is required whenever you request support or when you need to restore the system. Store the "Windows Me Quick Start" manual in a safe place so you can look up the Product Key number when you need it.

8. Register with the Microsoft.

You can register with the online system.

If you do not want to register immediately, you can register afterward.

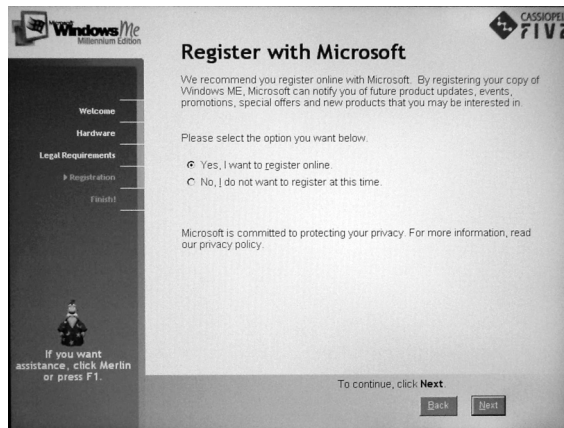

2

9. When **Setting is complete** appears, click the **Finish** button.

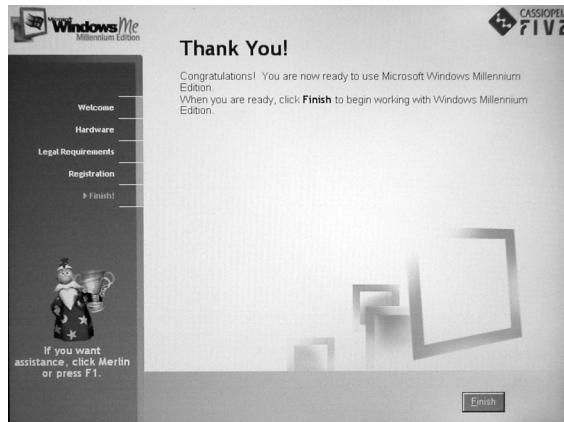

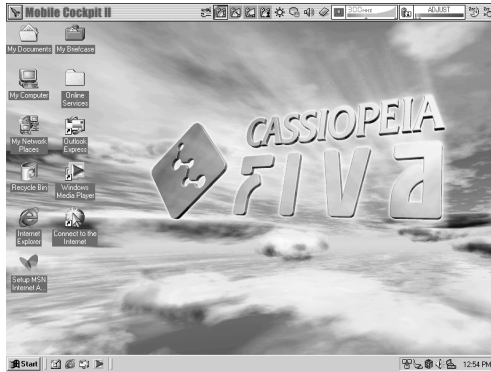

- The above screen appears after Windows Me setup is complete. Now Windows Me will start up whenever you turn on FIVA. For full details on using Windows Me, see the “Windows Me Quick Start Guide” manual that comes with FIVA.



This unit comes with a number of pre-installed applications. [See page 80](#) of this User’s Guide for information about how to use these applications.

Shutting Down the Power

This section describes various ways to turn off the power.

Select “Shut down”, “Restart”, “Stand by” or “Hibernate” from the Start menu.

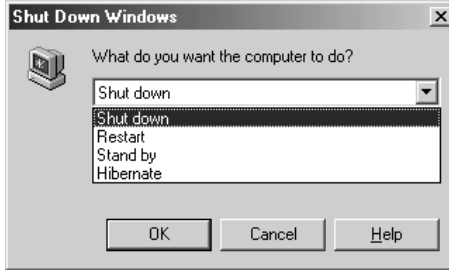

The following ways are also available.

- Slide the power switch so that the unit enters the “Stand by”, “Hibernate” or “Shut down” mode. However, if you keep sliding the power switch for more than 4 seconds, the system is quit forcibly and the power is turned off (see “Preferences “ on page 90).
- Close the display panel so that the unit enters the “Stand by” or “Hibernate” mode.

The amount of power FIVA consumes when the power is turned off and the time until Windows Me is reactivated differs in each of these power save modes.

Fully understand the features of each of these power save modes, and select the mode that best suits your particular requirements.

Mode	Storage for state	Time Unit Recovery	Power Consumption	Indicator Lamp
Power Off	None	Long (restart)	Almost zero	Off
Standby	Memory	Fast	Yes	Flashing
Hibernation	Hard Disk	Long	Almost zero	Off



FIVA’s default settings cause it to enter the **Standby** Mode if you do not perform any key or thumb pad operation for about 10 minutes under battery power alone. After another 10 minutes continuously without operation, FIVA enters the **Hibernation** Mode.

Important



FIVA with the power source only from battery pack may not completely recover if left in the **Standby** Mode for a very long time. If you do not plan to use FIVA for a long time, turn it off or put it in the **Hibernation** Mode.

To shut down Windows Me from the Start menu

In this mode, Windows Me is completely shut down and FIVA is consuming almost no battery power. This mode extends battery life but requires that Windows Me be restarted from the very beginning to restore power. This means that the status of Windows Me or any application that is running is not maintained in memory when the **Power Off** mode is entered. Enter the **Power Off** mode if you do not plan to use FIVA for a long time and before installing expansion memory.

1. Click the **Start** button on the Taskbar or press  on the keyboard.



Select this command.

2. Select **Shut Down...**
3. Select **Shut down** and then click the **OK** to shut down the computer.

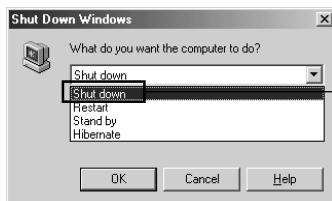

Choose this option.

To turn on the power again, slide the power switch to the right.

To restart Windows Me from the Start menu.

The current memory is saved in the hard disk and all the application are closed automatically. After that, Windows Me is quit and the system is restarted. If the performance speed becomes slow when an application is in function, restarting the system may restore to the original speed.

To enter the Standby Mode from the Start menu

The status of LCD, Windows Me and any applications that are running is retained in memory, so they can be restored in a shortest time after leaving the Standby Mode. In Standby Mode, FIVA always consumes slight power.

Sliding the power switch restores FIVA to the mode before you turn off the power.

Important



If you leave from FIVA for a long time when supplying power only from the battery pack, follow the procedure “To shut down Windows Me from the Start menu” or select “Hibernate” by following the procedure on the next page.

1. Click the **Start** button or press  to display the menu.

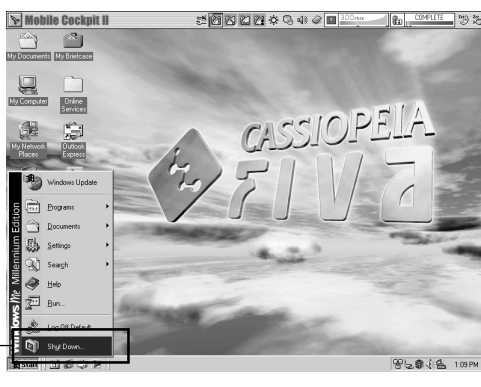

Select this command.

2. Select **Shut Down....**
3. Click **Stand by** and then click **OK**. The screen is closed and the unit enters the **Standby Mode**.

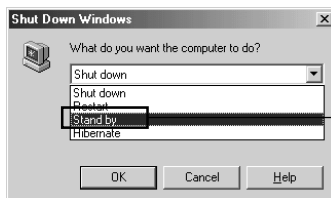

Select this option.

To enter the Hibernation Mode from the Start menu

The **Hibernation** Mode is recommended when you do not plan to use your computer for a long time, but you want to restore the status of Windows Me and your applications when you return.

The state of Windows Me and other applications that were active when the power save mode is entered are written to FIVA's hard disk. This process takes some to complete, after which FIVA automatically powers down so that almost no power is supplied.

Slide the power switch again to recover from the **Hibernation** Mode.

1. Click the **Start** button or press  to display the menu.



Select this command.

2. Select **Shut Down....**
3. Click **Hibernate** and then click **OK**. The screen is closed and the unit enters the **Hibernation** Mode.

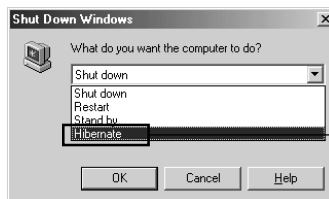

Select this option.

Important

- Avoid entering the **Hibernation** Mode while a communication operation is in progress, or while a peripheral (disk, printer, etc.) is in use. Entering the **Hibernation** Mode while a communication operation is in progress will cause a communication error on the other computer.
- You can reset FIVA and force power to turn off by holding down the power switch for 4 seconds. Note that FIVA does not beep if sound output is muted. Use this method to reset FIVA only when operation locks up and nothing else works.

To enter the Standby Mode and Hibernation Mode by closing the display panel

FIVA automatically enters the **Standby** Mode whenever you close the display panel. Reopening the display panel restores the Windows Me screen that was displayed when you closed it.







If you leave the display panel closed for longer than about ten minutes, FIVA automatically switches from the **Standby** Mode to the **Hibernation** Mode. To recover from the **Hibernation** Mode, open the display panel and slide the power switch. The Windows Me screen that was displayed when you initially closed the display panel reappears, but it will take more time than that of recovery from the **Standby** Mode.

Using the Sleep function

FIVE has the Sleep function to save power as a standard function.

This means the Hibernation Mode or Standby Mode described before. When this unit is not used temporarily, set the unit to the Sleep Mode so that the available time of battery pack can be prolonged. (The time to maintain the Sleep Mode differs according to the battery charge capacity of battery pack.)

If this unit is enters the Sleep Mode while only the battery pack supplies power, the PW-LED  indicator lamp will flash orange.

To enter the Sleep Mode, perform the following procedure.	To recover from the Sleep Mode, perform the following procedure.
Close the display panel (see page 49).	Open the display panel.
Select the Standby Mode from the Start menu (see page 47).	Slide the power switch.
Slide the power switch to enter the Hibernation Mode (see page 48).	Slide the power switch.
Press  +  to enter the Standby Mode (see page 29).	Slide the power switch.
Press  +  to enter the Hibernation Mode (see page 29).	Slide the power switch.
Click () from the mobile cockpit (see page 96).	Slide the power switch.
Click () from the mobile cockpit (see page 96).	Slide the power switch.

When the unit is recovered from the Sleep Mode, the screen that was displayed before entering the Sleep Mode is restored.

Turning On Power

Slide and hold the power switch (), and then release it when the PW-LED lights up.

Turning on FIVA power after you set up Windows Me starts up Windows Me.

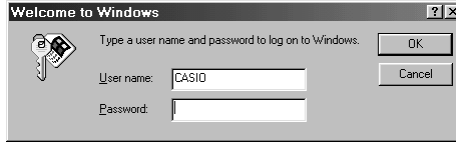

First, perform the log-on operation to make the unit recognize the user. If you use the unit alone and also not connected to a network, you can set the unit so that the screen above does not appear.



Important



Do not turn on and off in a short time.

When turning on the power again after turning it off, wait about 10 seconds after turning off the power.

When you want to adjust the LCD brightness, perform the following procedure.

- ① Adjusting the LCD brightness with the keyboard (see page 29).
To increase the LCD brightness, press **Fn** + **F1** ().
To decrease the LCD brightness, press **Fn** + **F2** ().
- ② Adjusting the LCD brightness with the Mobile Cockpit (see page 92).

Click the LCD brightness button () from the Mobile Cockpit. The LCD brightness can be adjusted up to 8 grades.

Using the Battery Pack

FIVA comes with a standard battery pack when you purchase it. Once you charge the battery pack, you can use FIVA without being connected to a power outlet via the AC adaptor. FIVA also has a number of power management functions that make battery operations more efficient.



See [page 33](#) for details about how to set the battery pack to FIVA, and [page 34](#) for information about charging the battery pack.

Checking the Current Charge Level of the Battery Pack

The battery pack discharges naturally even when you are not using it. To prevent the malfunction caused by the wear of battery pack, make sure you charge the battery pack fully before trying to use it to power FIVA.

You can use any of the three following methods to check the current charge level of the battery pack.

- The color of the BAT-LED indicator lamp
- The color of the PW-LED indicator lamp
- Mobile Cockpit

Checking the Battery Indicator Lamp Color

A green indicator lamp lit while FIVA is being powered by the AC adaptor indicates that the battery is fully charged. See [page 35](#).

When this happens, the “COMPLETE” message is displayed on Mobile Cockpit’s title bar. Charging is in progress when the indicator lamp is orange.



Checking the Power Indicator Lamp Color

The  indicator lamp will start flashing red and a warning screen will appear if the battery charge level drops while FIVA is operating under battery power only. When this happens, connect the AC adaptor and charge the battery.

If you continue to use FIVA under the low power condition, FIVA will automatically enter the **Hibernation** Mode when the battery charge level drops more.

When a warning screen appears, perform one of the following procedures.

- Connect the AC adaptor to this unit.
- Stop using this unit and turn off the power.
- Set this unit to the Sleep Mode and replace the battery pack with the fully charged one.

Important



If you turn on FIVA while the battery charge level drops, a warning message will appear and then FIVA will automatically shut down the power. When this happens, connect the AC adaptor and charge the battery.

 Power Indicator	Meaning
Lit orange	FIVA being powered by battery pack.
Flashing orange	Standby mode (with only battery pack in use)
Flashing Red	Low battery pack charge level (with only battery pack in use)
Lit Green	FIVA being powered by AC adaptor.
Flashing Green	Standby Mode (AC adaptor is used)

Checking with Mobile Cockpit

Mobile Cockpit's battery monitor function lets you graphically view the charge level of the battery at any time. [See page 86.](#)

You can obtain even more detailed information about the battery pack by displaying the Battery control.

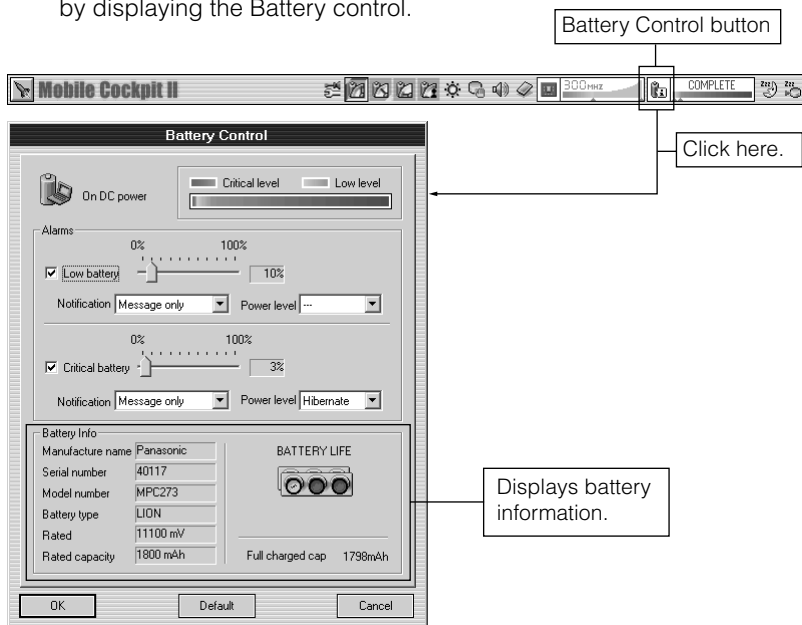

Using the Battery Pack Efficiently

The amount of operating time you get from the battery pack is greatly affected by operating conditions and how you use it.

FIVA's mobile computing Power Management Setting help to ensure that you get maximum power out of the battery pack. [See page 87.](#)



When the battery pack is not in use, remove it from this unit. The available time of the battery pack will be prolonged.

Forced Hibernation Mode

To help ensure that you do not lose application data files, FIVA goes into forced **Hibernation** Mode whenever the battery charge level drops below a certain point. When this happens, connect the AC adaptor and slide the power switch to recover from the **Hibernation** Mode.

When to Replace the Battery Pack

The battery pack is a consumable item, and after long use the amount of operating time provided by a fully charged battery can become quite short. This indicates it is time to replace the battery pack with a new one.

Important

Be sure you use the correct battery pack. On the “Options List” (page 141) comes with FIVA, find the battery pack whose model number matches the number marked on the battery pack.

You can also get an idea of the battery pack’s current condition by checking the Mobile Cockpit’s Battery Control.

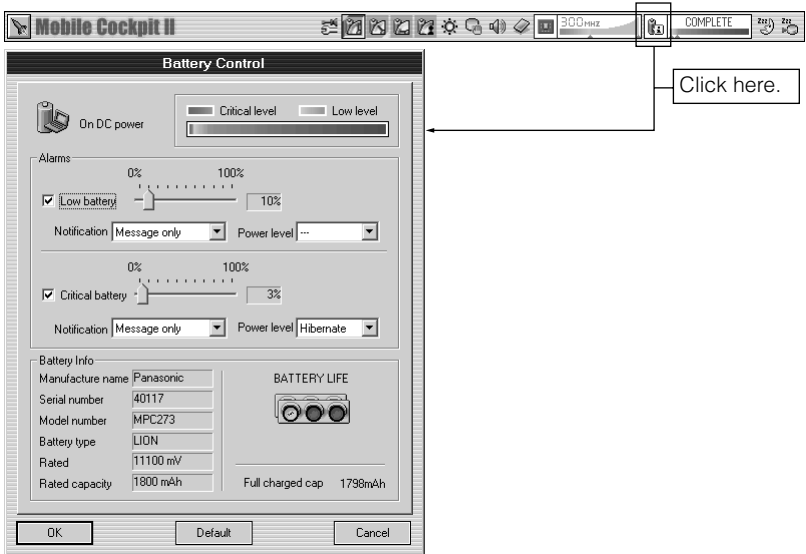

See “BATTERY LIFE” in the Battery Control of the Mobile Cockpit. If the signal is red, you have to replace with a new battery pack.

Important

The values that appear in the Battery control are provided for general reference only. Actual operability of the battery is affected by operating environment and other conditions.

Using the Large-capacity Battery Pack

Use the optionally available large-capacity battery pack when you need to operate FIVA for longer periods without AC adaptor power. The large-capacity battery pack provides about 9 hours of continuous operation on a full charge. Use the same procedure as the standard battery pack to attach and remove the large-capacity battery pack.

Important

Be sure you use the correct battery pack. On the “Options List” (page 141) , find the battery pack whose model number matches the number marked on the battery pack.

Using the One Touch Operation Buttons

There are 3 types of Keys; “E-mail button”, “Internet button” and “Memo button”.

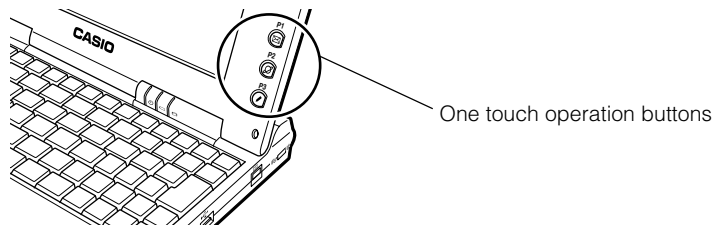

E-mail button (P1)

When the E-mail button () is pressed, the E-mail software starts up. The “Microsoft Outlook Express” is installed as the E-mail software when you purchase.

- For using the E-mail button, the setting to connect to an internet or the contract with an internet provider is also necessary beforehand. The various software applications, which allow you to connect to the internet provider via an internet and to sign up, are available.

Internet button (P2)

When the Internet button () is pressed, the internet browser starts up. The “Internet Explorer” is installed as the internet browser when you purchase.

- For using the Internet button, the setting to connect to an internet or the contract with an internet provider is also necessary beforehand. The various software, which allow you to connect to the internet provider via an internet and to sign up, are available.

Memo button (P3)

When the Memo button () is pressed, the “Microsoft Notepad” software starts up.

The “Notepad” is installed as the memo software when you purchase.

Changing the function of each button

The function of each button can be changed in the “Settings” → “One Touch Operating Button Setting” of the Mobile Cockpit. ([See page 86.](#))

Important



The “Mobile Cockpit II” activates the application function of the one touch operation buttons (P1: E-mail, P2: Internet, P3: Memo). Thus, directly after recovering from the Standby Mode or Hibernation Mode, or when there is no selected item, the one touch operation buttons may not function. In this case, press the appropriate button again or click on the screen.

Supplementary Information



Chapter 3

**This chapter contains information
about how to connect peripherals
and about convenient functions.**

Connecting Peripherals

Peripherals mean a CD-ROM drive, an external floppy disk drive, etc. that can be connected to this unit. This section describes how to connect peripherals and how to install PC cards or expansion memory.

For the peripherals that are not described in this User's Guide, see the manual that comes with the peripheral you are installing.

Important



Be sure to turn off the power of FIVA and unplug the power cord before connecting peripherals. Even for the peripherals that are compatible with the plug and play function, it is better to turn off the power before connection.

Connecting a pair of Headphones or a Microphone

By connecting commercially available headphones or microphone to this unit, the sound function built in this unit can be used.

To connect the headphones

Connect the headphones plug to the headphones port (🔊) on the front of this unit. For details of the volume adjustment, see “⑦ Adjusting volume” on page 92.

Use a pair of headphones set which has the stereo mini jack (ø3.5 mm).

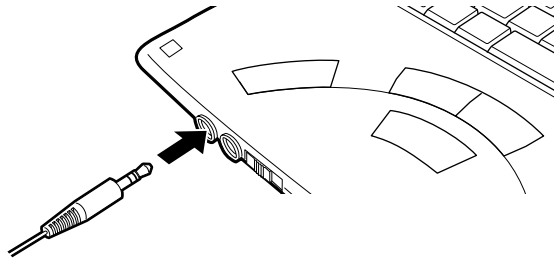

Connect the headphones plug to the headphones port (🔊).

To disconnect the plug, pull it out from the port by holding the plug.

Important



Do not use the headphones on the following occasions. Noise may be heard.

- When turning on/off the power of this unit.
- When connecting/disconnecting the headphones.

To connect microphone

Connect the microphone plug to the microphone port (🔊) on the front of this unit.

Use a microphone which has the monaural mini jack (ø3.5 mm).

Connect the microphone plug to the microphone port (🔊).

To disconnect the plug, pull it out from the port by holding the plug.

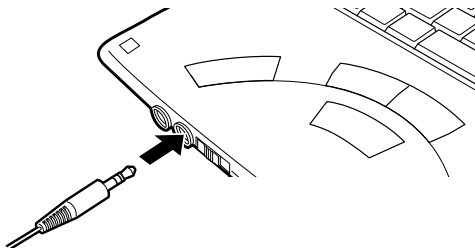

Connecting to the LAN port

By using the LAN port, you can connect to the standard Ethernet (10Base-T/100Base-TX). An Ethernet cable is necessary when connecting to the Ethernet. After connecting, setting the software is necessary in order to connect to the network using the TCP/IP function.

1. Connect one end of the Ethernet cable to the LAN port on the right side of the unit and the other end to the network.

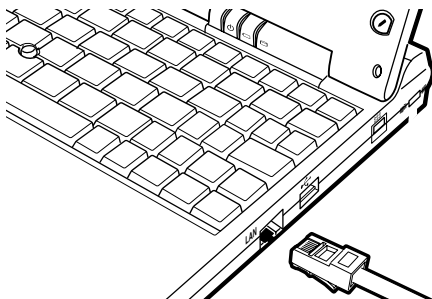

2. After connecting, perform the setting of the software to use the Ethernet.

Connecting to the modem port

The built-in 56kbps modem provides a high-speed data communication and facsimile transmission/reception capabilities. (The actual communication speed depends on the local line conditions, etc.) You can use this function by connecting the modular cable to the modem port.

The built-in modem can be connected to the general telephone line (analog). It cannot be connected directly to the digital line (the ISDN circuit, etc.). Also, it cannot be connected to the line for a home telephone or office telephone which uses the telephone switchboard. When connecting to the ISDN circuit, the optional terminal adaptor (TA), dial-up router, etc. is also necessary. After connecting, setting the software is necessary in order to perform the connection for communication via the telephone or facsimile line.

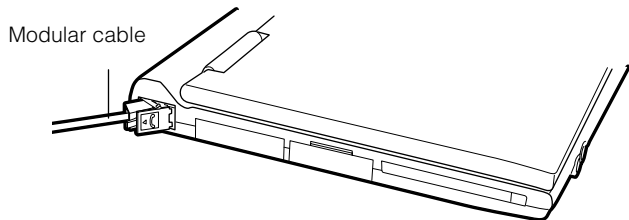

1. Confirm that the power of this unit is turned off.
Connecting or disconnecting the modular cable should be performed after turning off the power.
2. Open the lid of the modem port and insert one end of the modular cable securely until it clicks.

Important



- Do not transport the unit when the modular cable is connected to the modem port. It causes a damage of the modem port or the disconnection of the modular cable.
- When you make a dial-up connection to the pulse system telephone line using the built-in modem, it may malfunction and call up a wrong phone number unintentionally and fail to connect to the correct phone number. To avoid this, do not start up an application that causes frequent accesses to the hard disk. Also, do not connect the peripherals or access them before completing the dial-up connection.

Connecting to the USB port

The USB (Universal Serial Bus) is a standard interface specification for the connections of the USB compatible peripherals such as a keyboard, mouse, printer, scanner, etc. to the computer.

Connecting to or disconnecting from the USB port can be performed even when the power of this unit is turned on.

Insert the plug of the USB cable to the USB port securely with the plug's mark () facing upwards.

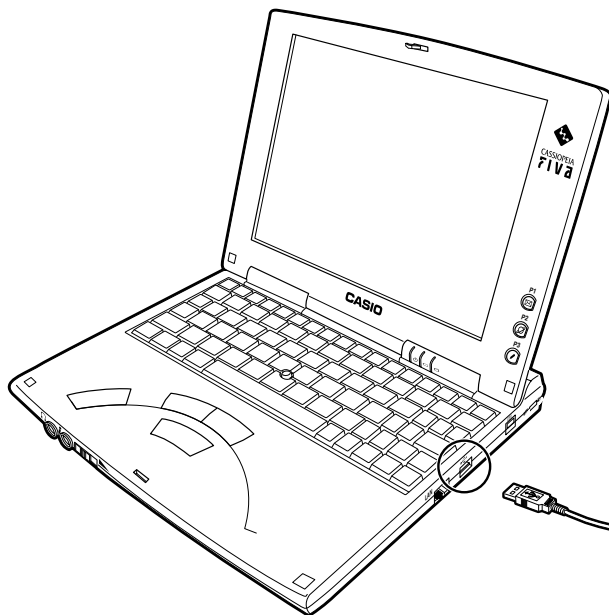

Important



- When this unit enters the Sleep Mode such as the Hibernation or Standby Mode while USB devices are connected, the USB devices may not be used after the unit is restored from the Sleep Mode. In this case, re-connect the USB devices or restart this unit.
- The compatible system (OS) and the driver is required for using USB devices.
- The performance of any USB compatible device connected to this unit must be checked thoroughly by the user.
- If one USB port on this unit is not enough, use commercially available USB hub. USB hub with power-supply capability is recommended.



Using the floppy disk drive

The optional USB compatible floppy disk drive (MPC-240FDD) is available for this unit. The two types of floppy disk can be used with this unit. One is 2DD floppy disk with the amount of 720 KB and the other is 2HD floppy disk with the amount of 1.44 MB. (For details, see the manual that comes with the floppy disk drive.)

Connecting the floppy disk drive allows you to store data and to copy data to other computer.

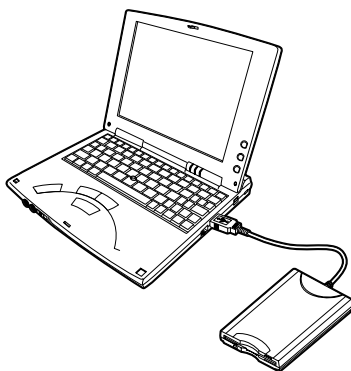

Connect the MPC-240FDD to the USB port of this unit.

The access lamp on the floppy disk drive lights while data is being written to or recalled from a disk. Never remove the floppy disk from the drive while the access lamp is lit. Doing so may cause malfunction of the floppy disk drive or corruption of data.



- When using the floppy disk that is not formatted for the Windows, formatting is required. However, the disk cannot be formatted to the disk with the amount of 1.2 MB.
- Once the disk is formatted, all data stored in the floppy disk is erased. Be careful when formatting the disk.
- The floppy disk that is formatted on other computer may not be used.
- The 2HD floppy disk that is formatted in the 2DD type cannot be used, and vice versa. Use a floppy disk that is formatted correctly.

To write protect a floppy disk

Floppy disks have a write protect tab that you can use to protect the data on them from accidental deletion or change.

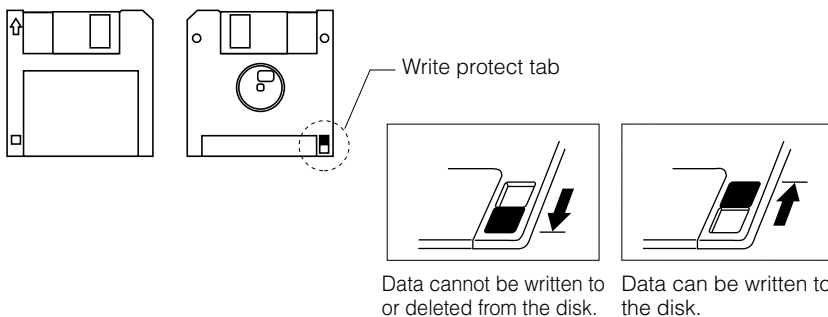

Data cannot be written to or deleted from the disk.

Data can be written to the disk.

Connecting a Printer

A USB compatible printer can be connected to the USB port of this unit.

Installing the printer driver is required for using the printer. The printer driver that comes with this unit or one (stored in a CD, floppy disk, etc.) that comes with the printer can be used.

When a printer compatible with the plug and play function is connected for the first time, the **Add Printer Wizard** screen appears. Follow the procedure displayed on the screen to use the printer.

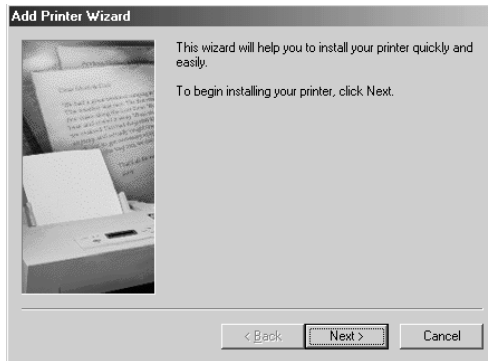

Using External Monitor

Connect an external monitor to FIVA so that the operation can be performed while viewing the big-screen. (Use the supplied RGB cable for the connection.)

Opening the display panel is required for using the external monitor as the unit enters the Sleep Mode automatically when the display panel is closed.

To connect a Monitor

1. Turn on the power of FIVA after closing an application, etc.
Making sure that the cable is oriented correctly, connect one end of the supplied RGB cable to the RGB port of this unit. Pull out the lid on the left side of the unit so that the RGB port appears.
2. Making sure that the connecting cable from the external monitor is oriented correctly, connect the connecting cable to the other end of the RGB cable.
Connect the power cord of the monitor to other power outlet. (For details, see the manual that comes with the monitor.)

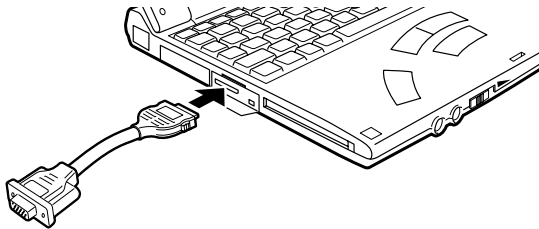

3. Turn on the power of the external monitor.
After that, turn on the power of FIVA and starts up Windows Me.
4. Press **[Fn] + [F10]** to switch to the external monitor.
Each time **[Fn] + [F10]** is pressed, the monitor function changes in the following order: LCD → External monitor → LCD and External monitor → LCD.

Important



- When disconnecting the RGB cable, hold the connector firmly while pressing the eject levers on both sides of the connector, and pull it out straight. Failure to do so may cause damage to the connector, or break the cable.
- When the external monitor connected to this unit is used, inserting the PCMCIA card (including the CF card) or updating the device driver with the **System** on the **Control Panel** may temporarily darken the monitor screen.
- The display screen momentarily goes blank when you change from one monitor function to another. This is not malfunction.



You can specify the resolution and number of colors only when using an external monitor. Right click on the Windows Me desktop and select **Properties** on the menu. The **Display Properties** appears.

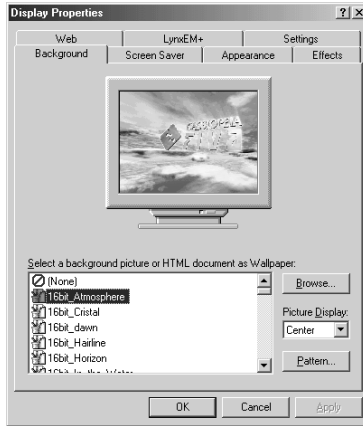

Click the Setting tab and then make the **Colors** and **Screen area** settings you want.



These settings can be changed.

The following table shows the setting combinations that can be made for **Colors** and **Screen area**.

Colors	Size (Pixels)
16-bit	640×480/800×600/1024×768
256 Colors	640×480/800×600/1024×768/1280×1024
16 Colors	640×480/800×600/1024×768/1280×1024

The screen may not be always displayed in all resolutions and numbers of colors depending on the external monitor.

Connecting to the IEEE1394 port

Various devices such as digital video camera, etc. can be connected to the IEEE 1394 port. The procedure to connect a device to the IEEE 1394 port is described in this section.

Connect the plug of the cable to the IEEE1394 port securely. Pull out the lid on the left side of the unit so that the IEEE1394 port appears.

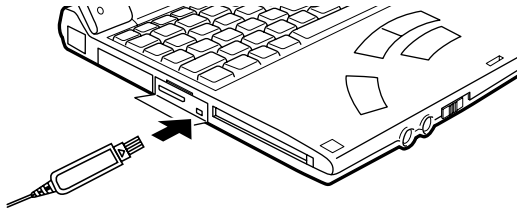

When a device compatible with the plug and play function is connected, the icon appears in the **My Computer** screen. Click the icon to perform the operation.

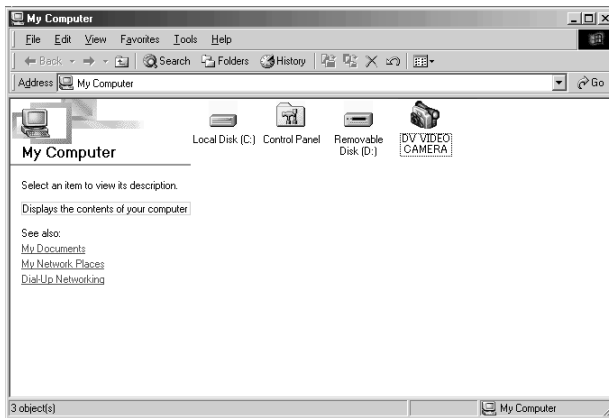

On the IEEE1394

- High-speed data transfer: It allows you to transfer multi-media data, etc. at dozens of times of speed compared with the speed when using the Ethernet.
- Plug and play: Turning off the power or restarting the unit is not necessary when connecting or disconnecting. Also, the dip switch or terminator is not necessary.

Using a PC Card

Using a PC Card

FIVA has one PC Card Standard PCMCIA TYPE II PC card slot (including card compatible with the Card BUS).

You can use a PC card to connect various peripherals such as the CD-ROM drive or scanner, etc. Almost of all PC cards can be inserted or removed while the power of the unit is turned on. For the detail of using the PC card, see the manual that comes with the PC card.

Important



- Long term use of PC card that generates a lot of heat can cause unstable card operation and malfunction and also can create the danger of burns.
- Never insert or remove a PC card while an application is running.
- Never insert or remove a PC card while the unit is in the Sleep Mode such as the Hibernation Mode or Standby Mode. Doing so may cause data to be erased.
- If you set the unit to the Sleep Mode or Hibernation Mode while a device connected to the PC card is in use, the unit may lock up when recovering. To prevent data from being erased or the unit from unexpectedly malfunctioning, you are recommended to select the **Close all applications before entering Standby or Hibernation** setting.
- When using a PC card that is not compatible with the hot insertion function, insert or remove the PC card after turning off the power of the unit.





You can use the "Product Recovery CD-ROM" that comes with FIVA to restore the hard disk. Use the optional CD-ROM drive (MPC-142CDD) that is for using a PC card.

Removing a PC card

Before removing a PC card from the slot, first click the Mobile Cockpit PC Card button () and disable PC card operation and then remove the PC card. Also, make sure that an application or system is not running. The PC card can be inserted or removed even when the power of this unit is turned on or off, but not when the unit is in the Sleep Mode.

1. Stop using the PC card.

Click the Mobile Cockpit **PC Card** button () or double-click the **PC Card** button () on the indicator area to open PC Card (PCMCIA) Properties. Select the card name from the list, and then click **Stop** to cut off the power to the PC card.

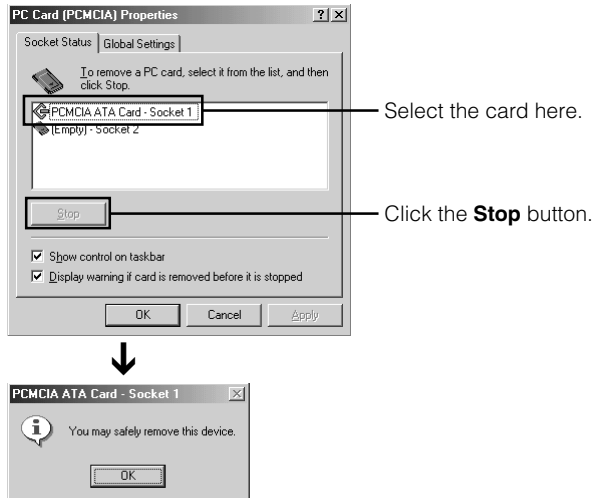

When “**You may safely remove this device.**” appears, click **OK**.

2. Press the PC card eject button.

When the PC card is ejected, pull it out the rest of the way by hand.

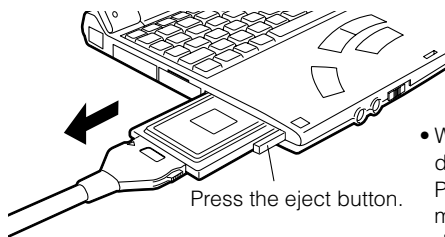

- When removing the PC card, do not pull the cable of the PC card. Doing so causes malfunction arisen from the disconnection, etc.
- When the eject button is pushed into the slot, press the head of the button again.

Inserting a PC card

Make sure that the PC card is oriented correctly when you insert it into the PC card slot. Inserting the PC card into the slot upside down forcibly may damage the cable or the slot.

1. Connect the cable to the PC card. And, push the eject button into the slot.

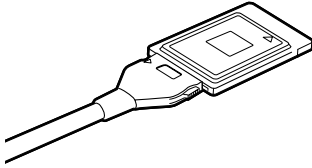

2. Making sure that the PC card is oriented correctly, insert the PC card into the PC card slot.

Though you may be aware of some resistance while inserting the PC card, push the card carefully and horizontally until it goes to the end.

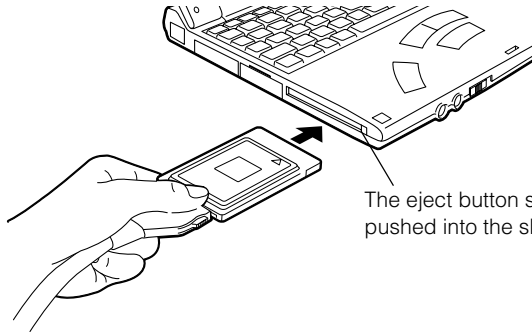

When you use the PC card for the first time, Windows Me automatically detects it and installs the appropriate software for it.

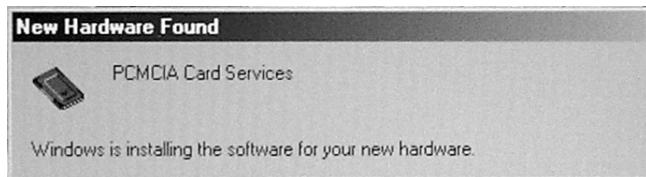

Using a CF Card

Using a CF Card

FIVA has one CF TYPE I/II CF (Compact Flash) card slot. You can use a CF card to load the expansion memory or hard disk. Almost all CF cards can be inserted or removed while the power of the unit is turned on. For the detail of using a CF card, see the manual that comes with the CF card.

Important



- Long term use of CF card that generates a lot of heat can cause unstable card operation and malfunction and also can create the danger of burns.
- Never insert or remove a CF card while an application is running.
- Never insert or remove a CF card while the unit is in the Sleep Mode such as the Hibernation Mode or Standby Mode. Doing so may cause data to be erased.
- When using a CF card that is not compatible with the hot insertion function, insert or remove the CF card after turning off the power of the unit.

Before using a CF card

The CF card is small so that it is hard to remove once you insert the card into the slot. For many CF cards, the direction you insert the card is printed on the card, but for some cards, the direction is not indicated clearly. So, before using a CF card, stick the supplied puller tape on the card as shown below.

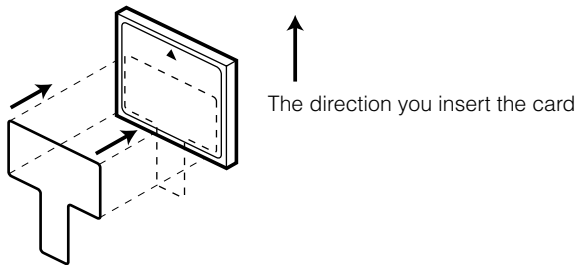

Inserting a CF card

Make sure that PC card is oriented correctly when you insert it into the CF card slot. Inserting the CF card into the slot upside down forcibly may damage the connector or the slot.

1. Remove the CF card slot lid. (Keep the lid in order not to lose it.)
2. Making sure that the CF card is oriented correctly, insert the CF card into the CF card slot.

Though you may be aware of some resistance while inserting the CF card, push the card carefully and horizontally until it goes to the last.

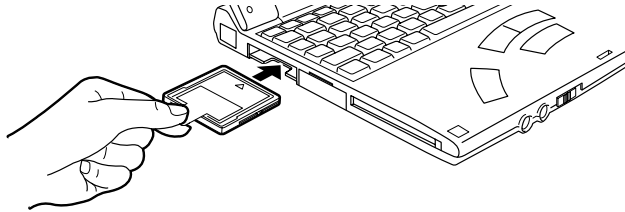

When you use the CF card for the first time, Windows Me automatically detects it and installs the appropriate software for it.

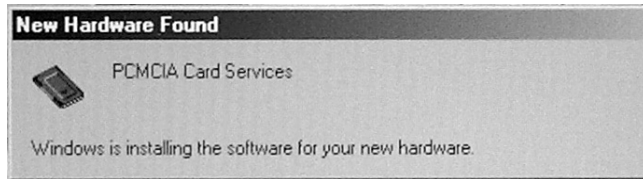

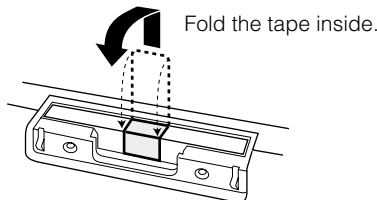

3. Fold the puller tape inside as shown below and cover the CF card slot with the lid.



Removing a CF card

Before removing a CF card from the slot, first click the Mobile Cockpit PC Card button () and disable CF card operation and then remove the CF card. And, be sure that an application or system is not running. The CF card can be inserted or removed even when the power of this unit is turned on or off, but not when the unit is in the Sleep Mode.

1. Stop using the CF card.

Click the Mobile Cockpit **PC Card** button () or double-click the **PC Card** button () on the indicator area to open PC Card Properties. Select the card name from the list, and then click **Stop** to cut off the power to the CF card.

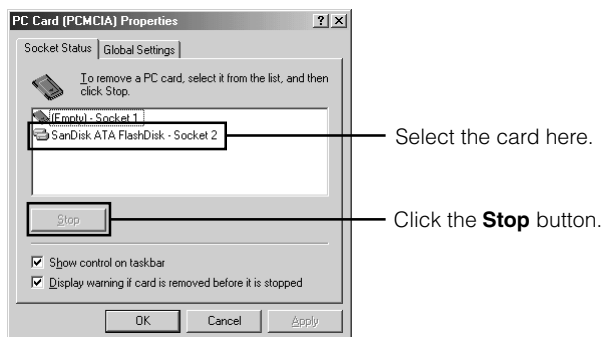

When **“You may safely remove this device.”** appears, click **OK**.

2. Remove the lid and pull out the puller tape on the card to remove the CF card.

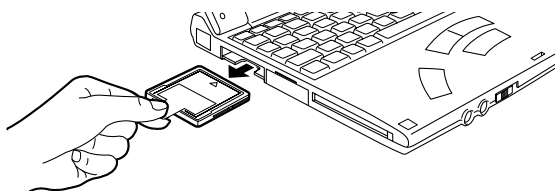

3. Cover the CF card slot with the lid.

Loading an Expansion Memory

You can expand the FIVA memory by installing an expansion memory board. Expanded memory can help applications and large-volume data to be operated at a high speed. Use the optional expansion memory board (MPC-252RAM/253RAM) or one specified by CASIO.

To increase the memory to maximum 192 MB, it is necessary to remove the expansion memory board from the expansion slot and install the optional expansion memory board (MPC-253RAM: 128 MB).

Before installing or removing expansion memory board



Do not disassemble the unit except the part described below. As the high-voltage components are inside FIVA, improper usage causes damage to the unit.



Do not place containers of liquids near FIVA and do not allow any foreign matter to get into it. Doing so creates the danger of shorting, fire and electric shock. If water or other foreign matter gets into FIVA, immediately shut down the power and contact your original retailer or authorized distributor.

Important



- The interior of FIVA can become quite hot during normal use. In this case, leave the unit for about 10 minutes to allow the interior of the unit to be cool before installing or removing the expansion memory.
- Shut down the power, unplug the AC adaptor and remove the battery pack before installing or removing the expansion memory.
- As the expansion memory is the precision electric product, it may be damaged by static electricity from your body. Be sure to touch a metallic object to discharge any static electricity from your body before installing the expansion memory.

Removing the expansion memory board

1. Quit all applications and shut down the power.
When the unit is in the Sleep Mode (Hibernation Mode or Standby Mode), restore the system and shut it down.
2. Disconnect the AC adaptor, power cord and all peripheral cables from FIVA. Then turn over the FIVA and remove the battery pack.

3. Turn FIVA again so that it is facing up.
Push the attachments towards the unit and lift them slightly (1) and then remove the hooks. And lift the attachments to remove them (2).

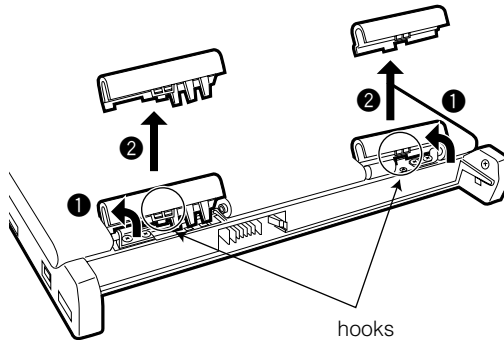

4. Open the display panel. Remove the two screws (+) on both sides of the keyboard and turn the keyboard toward you slowly. (Keep the screws in order not to lose them).
When turning the keyboard toward you, do not hold the keys. The keys may be removed.

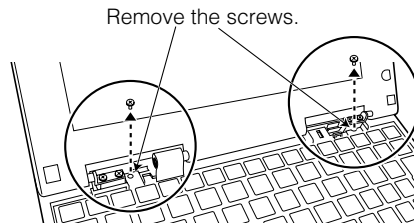

After removing two attachments, remove two screws.

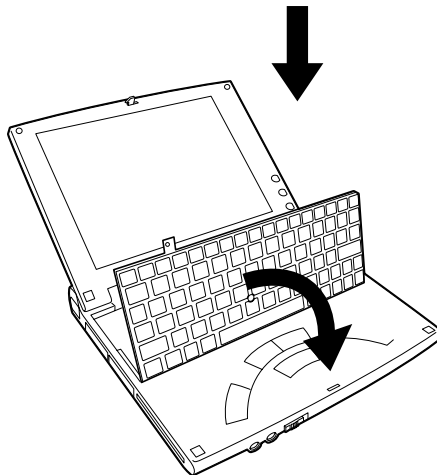

Turn the keyboard gently so that the keyboard turns over.

5. When the keyboard is removed, the expansion memory slot appears. Pushing the both sides of the expansion memory slot outwards (❶), pull the installed expansion memory board out (❷). Do not press down or bend the board when removing it.

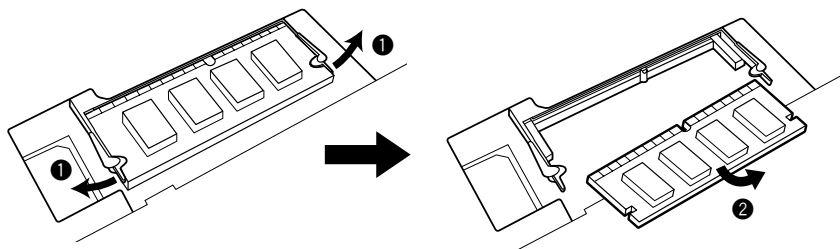

6. Steps 6 to 7 are the reverse procedure of steps 3 to 4. Replace the keyboard and secure it in place with the two screws (+).

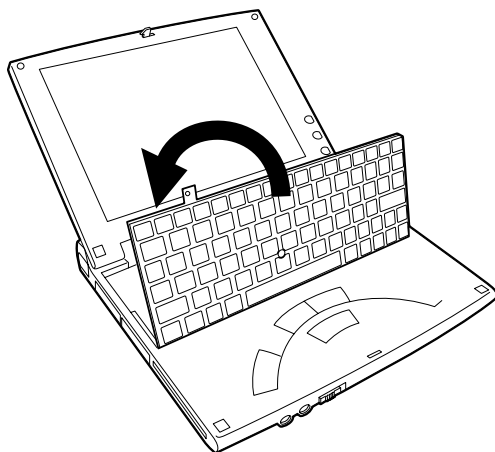

7. Replace the two attachments. Making sure that the direction and position are correct, put in the attachments by pressing them down from the top.

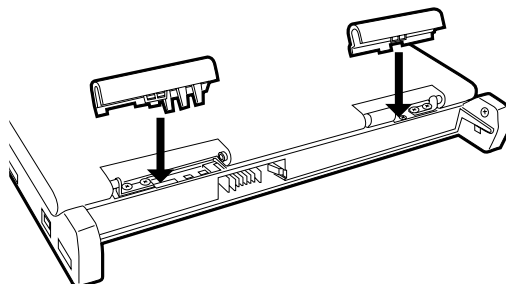

Installing the expansion memory board

Perform steps 1 to 4 of the procedure of “Removing the expansion memory board.”

5. When the keyboard is removed, the expansion memory slot appears. Aligning the depression of the expansion memory board (❶) with the protrusion of the expansion memory slot (❷), insert the board on the slant until it goes to the end (❸) after making sure that the board is oriented correctly, and then press it down (❹) until it is locked into place.

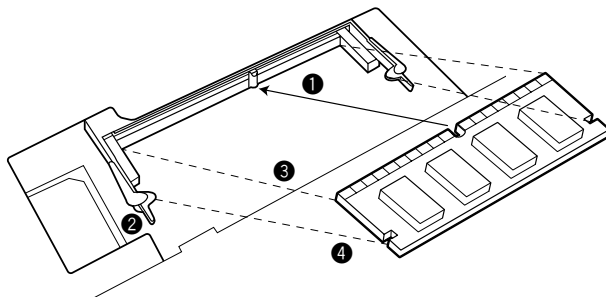

Perform steps 6 to 7 of the procedure of “Removing the expansion memory board”.

Checking the capacity of the expansion memory

Be sure to check that the expansion memory board is installed correctly and FIVA detects the expansion memory you installed. If the capacity of the expansion memory does not increase, the following problems are assumed:

- The memory board is not installed correctly, or
- The memory board is not a specified one by CASIO.









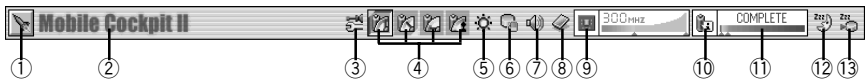







To check the capacity of the RAM (The amount subtracted 16 from the system memory.), click **Start** → **Settings** → **Control Panel** → **System** → **System Properties** → **General**. 16 is the capacity of RAM for using the system.

Using the “Mobile Cockpit II”

The CASIO original application software “Mobile Cockpit II” is installed in this unit. The “Mobile Cockpit II” is always displayed as a tool bar on the desk top of the Windows Me and it allows you to perform the convenient settings easily. When the “Mobile Cockpit II” is not displayed on the screen, click  in the indicator area to start up.

* After this, “Mobile Cockpit II” is described as the mobile cockpit.



Function	Button	Description	Page
① Switching the tool bar	 	Switches the display between the “Control bar” and the “Launcher bar”	81
② Panel		Changes the arrangement of the tool bar or hides the display.	84
③ Settings		Specifies the “One Touch Operation Buttons”, “Wake On Timer Setting”, “Power Management Setting” or “Settings (Preferences)”.	86
④ Power management	   	Set to each of the “Full power”, “Normal”, “Economy” or “User”.	91
⑤ Brightness control		Adjusts the brightness of display.	92
⑥ Stop functioning of the hard disk		Stops functioning the hard disk when the hard disk is not used.	92
⑦ Adjusting the volume		Adjusts sound level from the speaker	92
⑧ PC card properties		Specifies the settings to use the PC card.	93
⑨ Long-Run setting		Changes the speed of CPU.	94
⑩ Battery Control		Sets the warning for a low battery or displays the information about a battery.	95
⑪ Battery indicator		Displays the remaining power or the remaining time of the battery pack, etc.	96
⑫ Standby Mode		Sets this unit to the Standby Mode.	96
⑬ Hibernation Mode		Set this unit to the Hibernation Mode.	96

① **Switching the tool bar**

The Mobile Cockpit has the **Control bar** and **Launcher bar**. You can switch the display between them depending on your usage. When you click  or , the display is switched between the **Control bar** and the **Launcher bar**.

- **Control bar**

It allows you to specify each setting easily. When you click the appropriate button, the window appears. So, you can follow the procedure displayed in the window.



- **Launcher bar**

By registering the applications (up to 15 applications) in the tool bar, the applications start up when you click the button. It is convenient that you register the applications you often use.



Registering applications in the “Launcher bar”

To register applications you use from the Start menu.

1. Click **Start** in the Windows Me, select application from **Program** you want to register and then drag and drop it in the **Launcher bar**.

Drag and drop the application you want to register in the tool bar.



2. Confirm that the button of the application you registered is displayed in the **Launcher bar**.



To register applications from the “My Computer”.

1. Drag and drop application you want to register from the **My Computer** in the Windows Me to the **Launcher bar**.

Drag and drop the application you want to register in the tool bar.

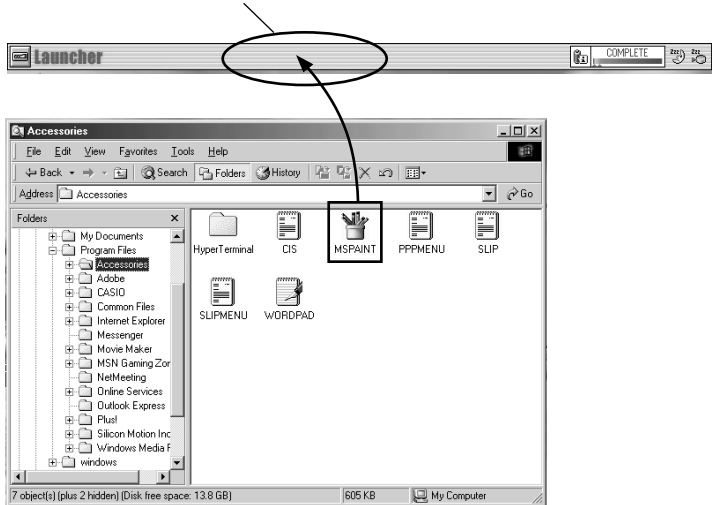

2. Confirm that the button of the application you registered is displayed in the **Launcher bar**.



To start up the application you registered

1. Clicking the **Switching the tool bar** button in the Mobile Cockpit to switch to the **Launcher bar** from the **Control bar**.
2. Click the button of the application you want to start up.
3. The application starts up.

To delete the application you registered

1. Clicking the **Switching the tool bar** button in the Mobile Cockpit to switch to the **Launcher bar** from the **Control bar**.
2. Right-click the button of the application you want to delete.

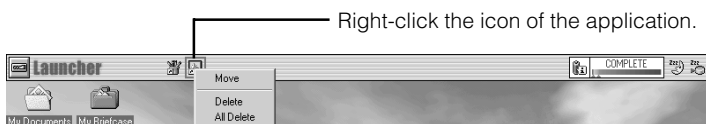

3. Click the **Delete** in the menu.
When you click the **All Delete**, all the applications you registered are deleted.

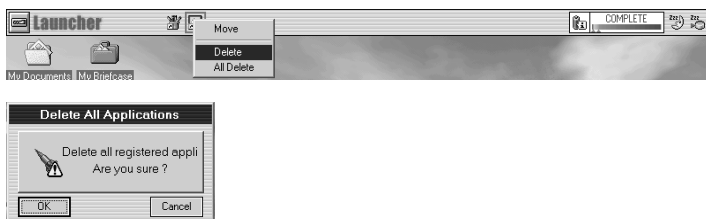

4. Confirm that the button of the application you deleted is not displayed in the "Launcher bar". (The button of the application is only not displayed. The application itself is not deleted.)

To move the application you registered

1. Clicking the **Switching the tool bar** button in the Mobile Cockpit to switch to the **Launcher bar** from the **Control bar**.
2. Right-click the button of the application you want to move.



3. Click the **Move** in the menu.
When it is clicked, the frame appears around the icon of application.
4. Right-click the button of the application you want to move and then drag to the desired position in the **Launcher bar**.

② Panel

Changing the display position of the tool bar

By dragging the panel, the “Mobile Cockpit II” can be displayed in the following 5 positions of the desk top screen.

The upper part of the screen



The lower part of the screen



The right side of the screen



The left side of the screen



As the tool bar is displayed together with the taskbar in the Windows is displayed preferentially, the short tool bar is displayed as shown above when the tool bar in the Mobile Cockpit is displayed in the left or right side of the screen.

Floating



The tool bar can be displayed on the desired position of the screen.

Pop-up menu

When you right-click this part, the pop-up menu is displayed.



Auto hide

When the check mark is put in the **Auto hide**, the tool bar is hidden. In this setting, when you move the pointer to each corner of the screen, the tool bar appears and when you move the pointer aside from the corner of the screen, the tool bar is hidden. When the check mark is not put, the tool bar is always displayed.

Always on top

The tool bar in the Mobile Cockpit is always displayed in front. This setting allows you to display the tool bar in front even when other windows are displayed.

Sound Effect

The effective sound can be heard when you click each button of the Mobile Cockpit. This lets you know that inputting is performed.

Help

When you need the information about the Mobile Cockpit, this lets you know how to operate.

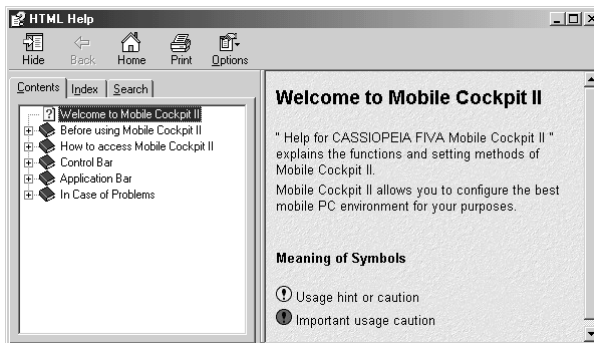

Version info

This displays the version information of the Mobile Cockpit.



Exit

This closes the application of the "Mobile Cockpit II". When you want to use the tool bar of the "Mobile Cockpit II" again after closing it, you need to start up from the "FIVA tool".

③ Settings

You can specify 4 settings of the "One Touch Operation Buttons", the Wake On Timer, Power Management and Settings.



One Touch Operation Button Setting

The one touch operation buttons have three buttons of P1 (✉) "Mail button", P2 (🌐) "Internet button" and P3 (📝) "Memo button". When you press each button, the application you registered in advance starts up. You can register desired application in each of one touch operation buttons.

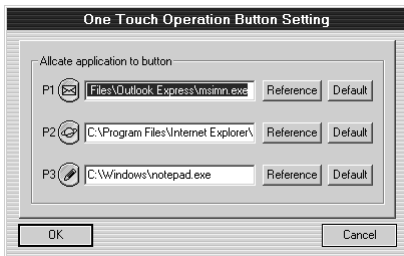

You can display the Windows standard files by pressing the referring button and select desired application and then register it in each of one touch operation buttons. If you do not register the application in the button, leave the textbox vacant. In this case, the application does not start up even when you press the button. In the default setting, the “Microsoft Outlook Express”, the “Internet Explorer” and the “Note pad” are registered in the “Mail button”, the “Internet button” and “Memo button” respectively.

Wake On Timer Setting

You can specify the way to restore from the Sleep Mode by putting the check mark in the check box.

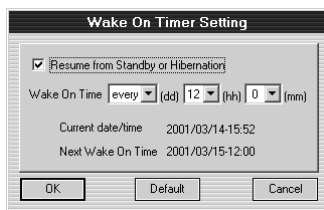

In the Sleep Mode (the Standby Mode or the Hibernation Mode), this unit can be restored from the mode when the day and time you set comes.

Power Management Setting

This allows you to prolong the using time of the battery pack when you change the settings of the Sleep Mode, CPU, hard disk and the LCD monitor and the power supply according to the conditions. (This function is called “Power Management”.)

To make the change of the using condition easier, the three modes of “FULL POWER”, “NORMAL” and “ECONOMY” are provided. And, for the power, the two modes of “USER AC” and “USER DC” are provided. The three modes and the two modes can be specified respectively. The following items can be specified. In this window, the power management setting for the system and the devices can be specified by selecting “USER AC” or “USER DC”, and the setting for this unit can be specified by selecting “FULL POWER”, “NORMAL” or “ECONOMY”.

- The time until this unit enters the Sleep Mode after the unit is not used.
- The speed of CPU (Long-Run setting)
- The time until the function of hard disk stops after the unit is not used.
- The brightness of the display
- The time until nothing is displayed in the LCD monitor after the unit is not used.

Important

You can also specify the power management setting of this unit by selecting “Control panel” → “Power Management” → “The property of Power Management”. Note that the setting in the “Power Management” has priority over the setting of the “Power Management Setting” in the Mobile Cockpit. The setting of the “Power Management Setting” in the Mobile Cockpit is cancelled when the setting in the “Power Management” is performed after the setting of the “Power Management Setting” in the Mobile Cockpit is performed. Normally, you should specify only the setting of the “Power Management Setting” in the Mobile Cockpit because it is easier to operate.

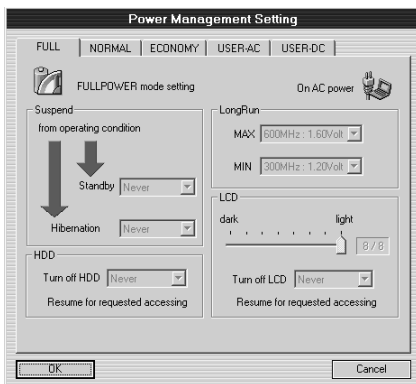
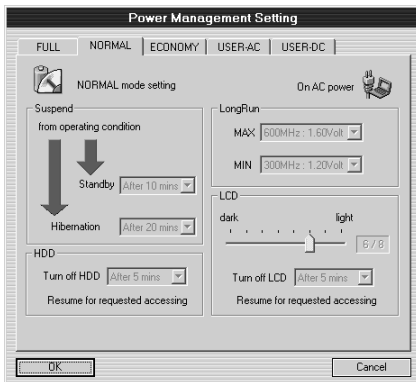
FULL POWER**NORMAL**

ECONOMY

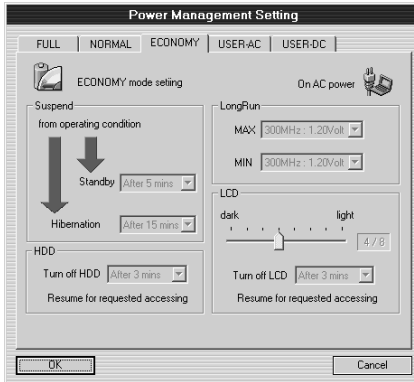

USER AC

This setting is when the power is supplied to this unit by the AC adaptor.

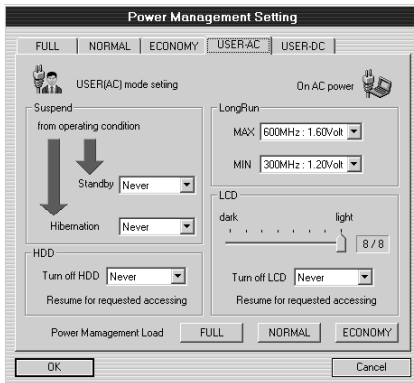

USER DC

This setting is when the power is supplied to this unit by the battery pack.

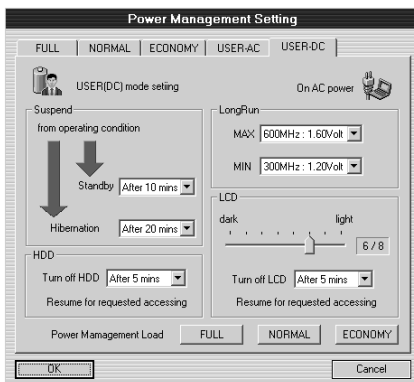

Settings (Preferences)

The initial setting can be set to use this unit. The 5 settings of “Built-in LAN on/off”, “Priority of starting up devices (Boot sequence)”, “Power Switch Action”, “LCD Panel Action” and “Switch the PC Card/PC Card Pro button” can be specified.

When the restart is necessary after the setting is changed, the display to restart this unit appears after you press the **OK** button.

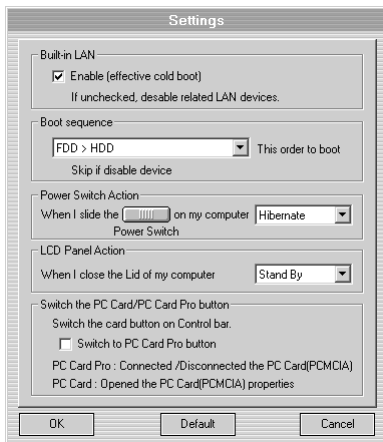

Built-in LAN on/off

When you do not use the built-in LAN, remove the check mark from the check box .

Priority of starting up devices (Boot sequence)

The priority of the devices when the power of this unit is turned on (when the unit is in function) can be specified from the selecting list. The unit ignores the device that cannot be detected when searching, and searches for the next device.

[The selecting list]

- FDD > CDROM (PCMCIA) > HDD
- FDD > HDD
- HDD > FDD

Power Switch Action

You can set to each of the “Stand by”, the “Hibernate” or the “Shut down” when you slide the power switch to turn off the power while the unit is used.

LCD Panel Action

You can set to each of the “None”, the “Stand by”, the “Hibernate” or the “Power Off” when you close the display panel while the unit is used.

Switch the PC Card/PC Card Pro button

You can change the setting of the “PC card” button of the tool bar in the Mobile Cockpit according to this setting.

(See ⑧ [PC card properties on page 93.](#))

④ **Power management**

When the button is depressed.



When you press one of the “Full power”, the “Normal”, the “Economy” and the “User” button to select the setting of the “Power Management Setting” described before, the setting of the power management for this unit can be specified.

The selected button is depressed. (The “Full power” button is selected in the illustration shown above.)

The power condition is shown in the indicator of the selected button when you switch to the AC adaptor or to the battery pack.

- When the AC adaptor is used, the indicator on the upper left of the button is turned on or off according to the operation you click the icon.
- When the battery pack is used, the indicator on the lower right of the button is turned on or off according to the operation you click the icon.

⑤ **Brightness control**

You can adjust the brightness of LCD monitor.

Adjust the brightness of LCD monitor by dragging the control bar. After adjusting it, click the “Save the user mode” to save the items of the “LCD monitor

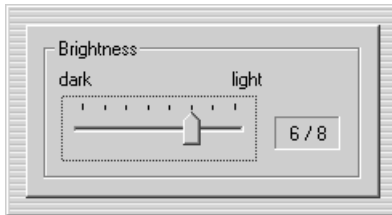

setting” in the “Setting of power management” described before. If you do not save the setting, the LCD monitor is displayed in the brightness previously set in the “LCD monitor setting” of the “Setting of power management” when you restart the unit.

- Also, you can adjust the brightness of LCD monitor using the hot key combinations such as “**Fn** + **F1** (☀️▲)” or “**Fn** + **F2** (☀️▼)”.

⑥ **Stop functioning of the hard disk**

This setting stops functioning the hard disk when the hard disk is not used. So, you can prolong the using time of the battery pack because the power to the hard disk is reduced. Even after the function of the hard disk stopped, the hard disk resumes functioning when the access to the hard disk occurs.

⑦ **Adjusting the volume**

You can adjust the volume for the speaker. Adjust the volume by dragging the control bar. When you put the check mark in the check box of the “mute”, the sound is muted.



- Also, you can adjust the volume using the hot key combinations such as “**Fn** + **F5** (🔊▲)” or “**Fn** + **F6** (🔊▼)”.

⑧ PC card properties

This button has the two functions and the display can be switched in the “Settings” described before.

The  button opens the PC card properties (PCMCIA) of the Windows.

The  buttons connects or disconnects two PC cards each other.

An example of “Settings”

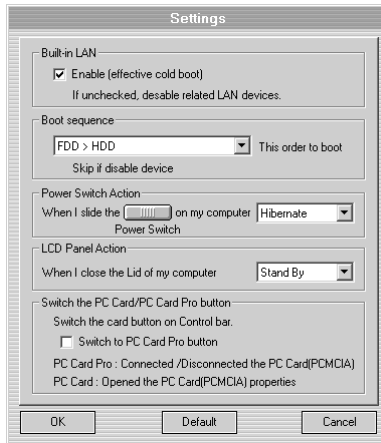

button

Selects **Control panel** → **PC card (PCMCIA)** and opens the PC card (PCMCIA) properties window.

When you remove the PC card, perform the operation in this window.

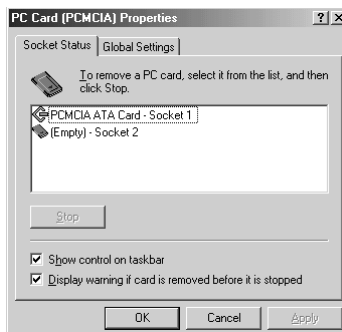

You can remove all storage devices including the connected PC card using the **Removing the hardware** button in the indicator area.

button

Connects or disconnects the PC card (PCMCIA). When this button is clicked, this unit confirms the connecting condition of the PC card, and connects the PC card when the PC card is disconnected, or disconnects it when it is connected.

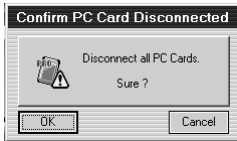

- Connecting operation
After inserting the PC card into the slot of this unit, click the  button. The connecting operation is automatically performed with the plug and play function.
- Disconnecting operation
The unit stops the PC card function and disconnect the PC card. The operation in the PC card (PCMCIA) properties window is not required. When the screen of disconnecting disappears, remove the PC card.

⑨ Long-Run setting

By setting the function range of CPU of this unit, you can decrease the power consumption and prolong the using time of the battery pack. The CPU functions within the upper value and the lower value. After setting it, click the **Save the user mode** to save the items of "LongRun" in "Power Management Setting" described before. If you do not save the setting, the unit functions in the CPU speed previously set in "LongRun" of "Power Management Setting" when you restart the unit.

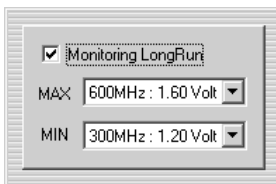

Click ▲ to display the upper value and lower value you specified. When you click the displayed value, the display is switched between the CPU speed and the voltage.



10 Battery Control

This window displays the condition of the battery pack. You can check the connecting condition of the battery pack, the remaining power of the battery pack or the time to replace with the new battery pack, etc.

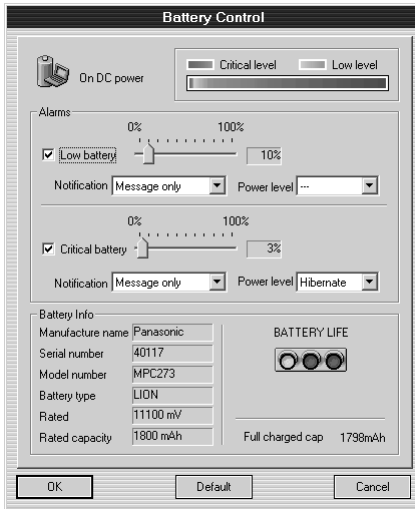

The reading of the Rated capacity does not guarantee the actual capacity of the battery pack which is being used. Therefore the capacity of the full-charged battery pack and the Rated capacity do not coincide with each other.

When you click the battery control button while power is supplied from the AC adaptor, the “On AC power” screen shown below appears.

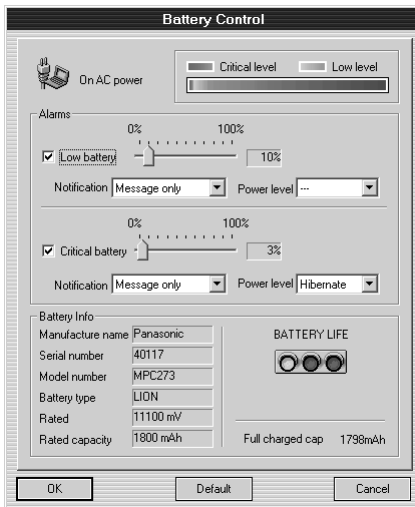

⑪ **Battery indicator**

This indicator always displays the remaining power or estimated remaining time of the battery pack, etc.

- When using only the battery pack

The estimated remaining time of the battery pack is displayed.



- When using the AC adaptor and the battery pack

The estimated time to reach a full charge is displayed.



- When using only the AC adaptor

“NO BATTERY” appears.

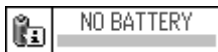

- CALCULATE

“CALCULATE” appears right after the battery pack is installed. If this message remains to

be displayed, install the battery pack once again, or the replacement with the new battery pack is required because of the exhaustion of the battery pack.

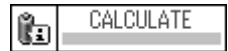



⑫ **Standby Mode**

When you click the standby button () , this unit enters the Standby Mode.

- You can also set to the Standby Mode by pressing “**Fn** + **F3** ()”, selecting “Standby” after selecting the “Shut down”, or performing the operation of “③ Settings” described before. If you click this button when the wake on timer setting is set to on, the unit is restored from the Standby Mode when the time you set comes.

⑬ **Hibernation Mode**

When you click the hibernation button (), this unit enters the Hibernation Mode.

- You can also set to the Hibernation Mode by pressing “**Fn** + **F4** ()”, selecting “Hibernation” after selecting the “Shut down”, or performing the operation of “③ Settings” described before. If you click this button when the wake on timer setting is set to on, the unit is restored from the Hibernation Mode when the time you set comes.



Appendix

This appendix tells you how to solve the problem and how to restore FIVA to the default settings.

System Restoration

Using the supplied “Product Recovery CD-ROM”, you can restore the system and applications back to the factory defaults.

When Windows Me does not function correctly or when Windows Me does not start up even if you turn on the power, restore the system with the supplied “Product Recovery CD-ROM” (after this, the way to resume the system is described as “System restoration”).

- The optionally available CD-ROM drive is required to use the “Product Recovery CD-ROM”. Only the specified drive can be used. [See “Option List” on page 141.](#)

Important



- Keep “Windows Me” and “Product Recovery CD-ROM” securely. The reissue is not available.
- System restoration deletes all data stored on the hard disk. Be sure to make regular, even daily backup copies of all important data to protect against loss, and keep them separately from the hard disk.
- Be sure to power FIVA with the AC adaptor whenever restoring the system. Low battery power can cause the procedure to be aborted, which requires starting again from the beginning.

To restore the system, perform the following procedure.

Before restoring, be sure to set the software switch to MODE A and set the BIOS to the default setting. Never reset the Start-up mode switch while restoring.

Starting up from the “Product Recovery CD-ROM”

Though FIVA is preset to start up from its hard disk, you can start up FIVA from “Product Recovery CD-ROM” in a CD-ROM drive to restore the system and applications. The following procedure is performed with the CD-ROM.

1. Turn off FIVA and disconnect all peripherals.
2. Connect the CD-ROM drive.
3. Insert the “Product Recovery CD-ROM” into the CD-ROM drive.
4. Turn on FIVA.
5. The CASIO logo appears.

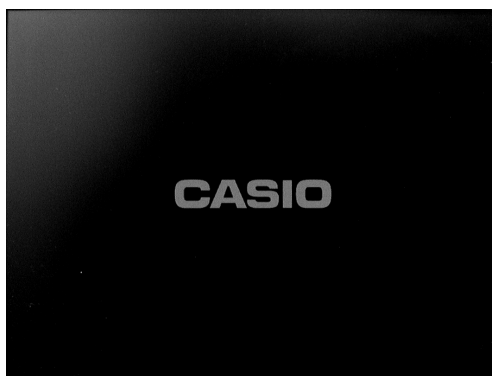

6. Press **[F2]** a few times. The CASIO logo screen changes to the “BIOS Setup Utility” screen.
7. Select **Exit** using the → key, and select **Load Setup Defaults** in third line, and then select **[Yes]**.
8. Select Boot using the → key, press **[Enter]**, and then select **Enabled**. After that, press **[Enter]**.
9. Select **Exit** using the → key, and select **[Yes]**.

Setting the Partition of Hard Disk/Initializing the Hard Disk

Starting up from the “Product Recovery CD-ROM” automatically starts the system restoration routine. Follow the instructions that appear on the screen.

1. Specify hard disk space which should be allocated for **Hibernation Mode** data.

Start up from the “Product Recovery CD-ROM,” and the screen shown below appears after an initial process is performed. Type **[Shift] + [Y]** (upper case **[Y]**) to delete all data on the hard disk and start installation.

```
*****
*                CASSIOPEIA FIVA RECOVERY CD-ROM                *
*                *
* Copyright (c) 2000-2001, CASIO COMPUTER CO., LTD. All right Reserved.*
*                *
*****

Type upper-case Y to automatically launch the FDISK and FORMAT commands.
This deletes all the contents of your hard disk and reinstalls the system.

Type upper-case N to cancel without doing anything.

OK to continue? [Y,N]?_
```

Important



Typing **[Shift] + [Y]** deletes everything currently on the FIVA hard disk. If you change your mind and want to stop this procedure, type **[Shift] + [N]** (upper case **[N]**).

Note

Typing **[Y]** here also executes the FDISK command, which creates a hard disk partition. The partition reserves part of memory for storage of data when the system goes into the **Hibernation Mode**. After that, the partition for the Hibernation Mode is formatted automatically.

2. Creating the Linux preferences.

```
=====
Initialize the Linux environment
=====
Please wait a little.
```

For details of Linux, see the supplied booklet.
After that, the hard disk will be initialized.

3. After restarting, change CD-ROM.

After hard disk initializing is complete, remove the “Product Recovery CD-ROM” and insert the “Microsoft Windows Me Operating System CD-ROM” into the CD-ROM drive. Next, press any key.

```
=====
Hard disk initialization complete.
=====

Remove the RECOVERY CD-ROM and
Insert the CD-ROM marked [Microsoft WindowsMe].

Next, press any key to continue.
-
```

Important



Do not turn off CD-ROM drive power when you change the CD-ROM.

4. Start installation of Windows Me.

When the screen shown below appears, press **Enter**.

```
Microsoft Windows Me Setup
=====
Welcome Setup.

The Setup program prepares Windows Me to run on your
computer.

  * To set up Windows now, press ENTER.
  * To learn more about Setup before continuing, press F1.
  * To quit Setup without installing Windows, press F3.

Note: If you have not backed up your files recently,
you might want to do so before installing Windows. To back
up your files, press F3 to quit Setup now. Then, back
up your files by using a backup program.

To continue with Setup, press ENTER.

ENTER=Continue  F1=Help  F3=Remove Color
```

5. Run Scan Disk.

When the screen shown below appears, press **Enter** to starts Scan Disk. Scan Disk checks the hard disk for errors.

```
Setup is preparing to install Windows
Please wait while Setup initializes.
Setup is now going to prepare a routine check on your system.
To continue, press ENTER. To quit Setup, press ESC_
```



Note Scan Disk is a program that checks hard disk for errors, and corrects any errors it finds.

6. Exit Scan Disk.

After Scan Disk finishes its check, type **◀Exit▶** to exit it.

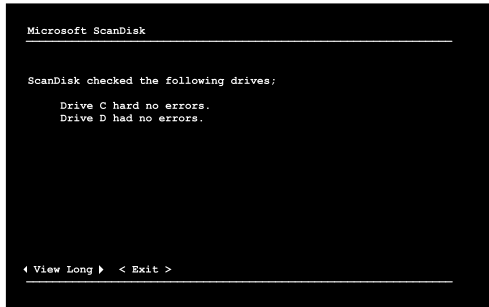

Exiting Scan Disk changes starts Windows Me installation.

The screen changes, and FIVA prepares for Windows Me installation and the Windows Me installation wizard starts.

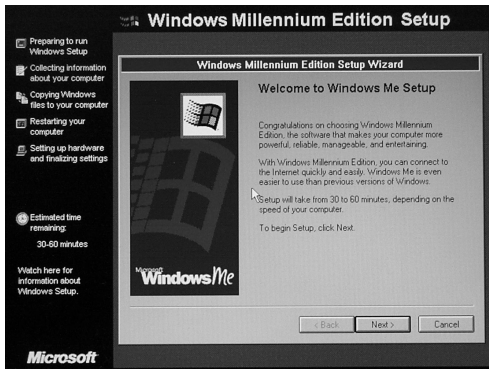

Click Next.

7. Select the directory where you want Windows Me installed.
Make sure that **C:\WINDOWS** is selected as the installation directory, and then click **Next>**.

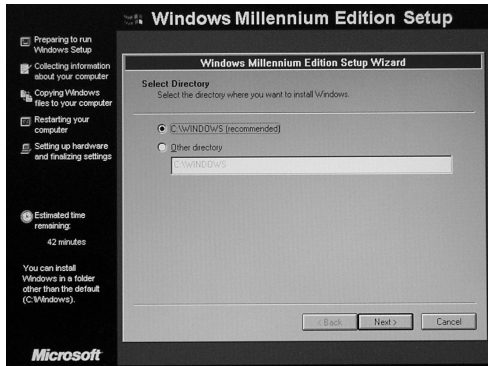

If you want to install Windows Me in a different directory, select “Other directory”, and then type in path to the directory. Of course, you can leave the default **C:\WINDOWS** as it is.

8. Select the kind of setup you want.
Make sure that **Typical** is selected and then click **Next>**.

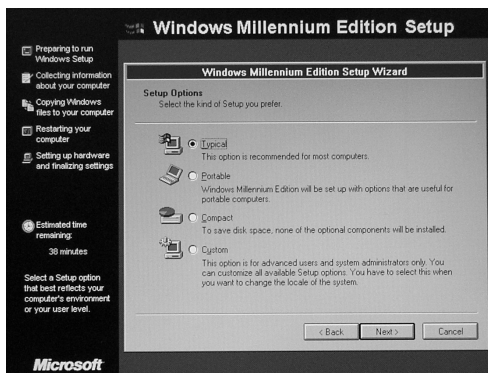

Important



You can select another setup option if you like, but be sure to select **Typical** if you want to restore the system to its initial factory defaults. For details, see [“Installing the CASIO Applications” on page 116](#).

9. Select the Windows Me files you want installed. Make sure that “Install the most common components recommended.” is selected, and then click **Next>**.

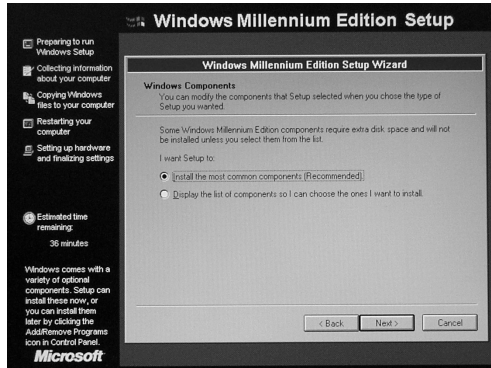

Important



You can select “Display the list of components so I can choose the ones I want to install.” you like, but be sure to select “Install the most common components recommended.” if you want to restore the system to its initial factory defaults.

10. Specify your geographic area.

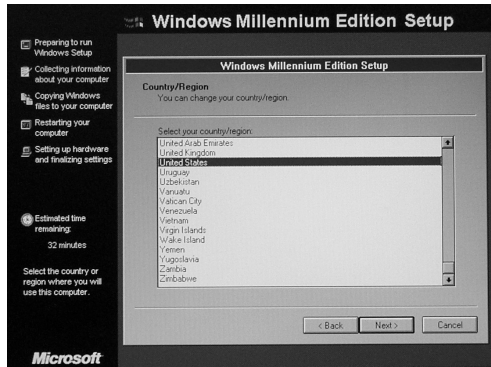

11. Specify your time zone.

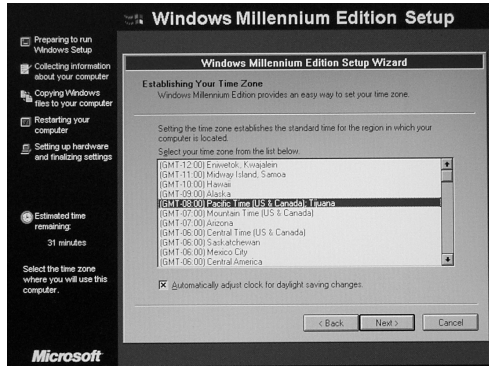

12. Skip the screens for making a startup disk. Click **Next** on the screen shown below.

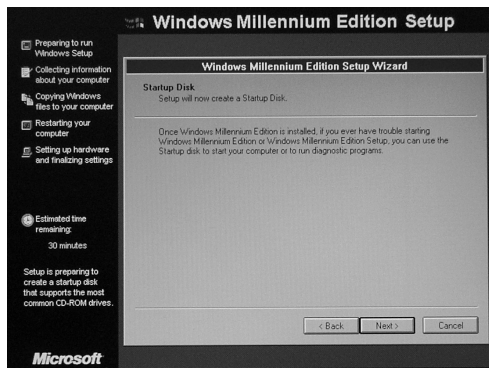

A startup disk is a floppy disk that can be used when Windows Me does not start up correctly. You can find the cause Windows Me does not function correctly by starting up the system with the startup disk and performing troubleshooting steps.

Click the Cancel button when the screen below appears.

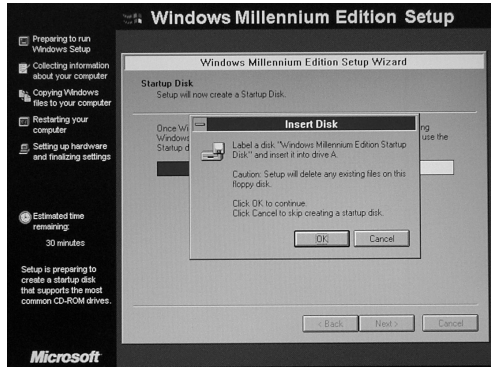

In response to the confirmation message that appears, click **Cancel**. The screens for making a startup disk is skipped. A startup disk will be made after the installation of Windows Me is complete.

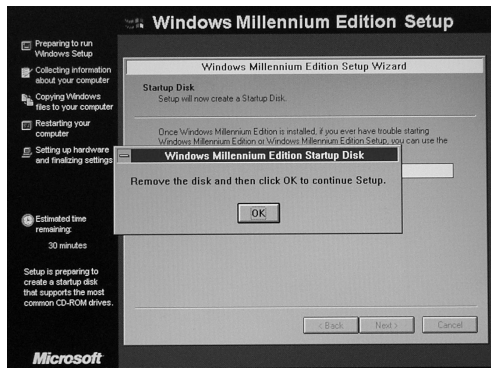

- See page 121 for details on making a startup disk.
- The CD-ROM drive is treated as Drive A: during the system restoration operation. Because of this, you will be unable to make a startup disk with the connected floppy disk drive. This is why you skip the above screens at this point and make a startup disk later.

13. Start the file copy operation.

When the screen shown below appears, click **Finish** to start the file copy operation.

It takes about 15 minutes to copy all files. After that, you do not need to operate. Windows Me is installed automatically. FIVA will automatically restart with Windows Me when the installation of Windows Me is complete.

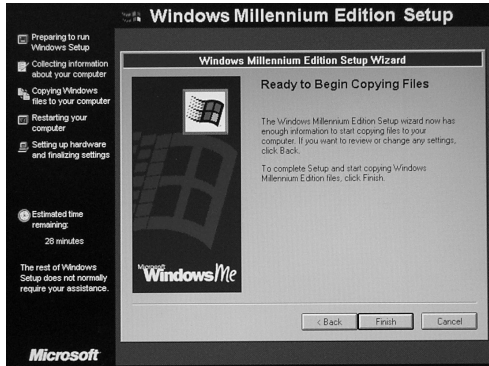

14. After FIVA restarts, the following screen appears. Click **OK.**

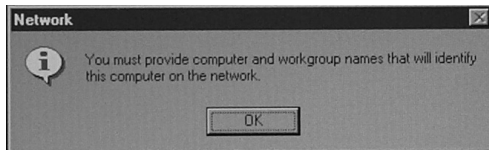

15. Specify the computer name and work group name respectively. Input a computer name and work group name and then click **Close**. For example, Input “FIVA” as a computer name and “CASIO” as a work group name.

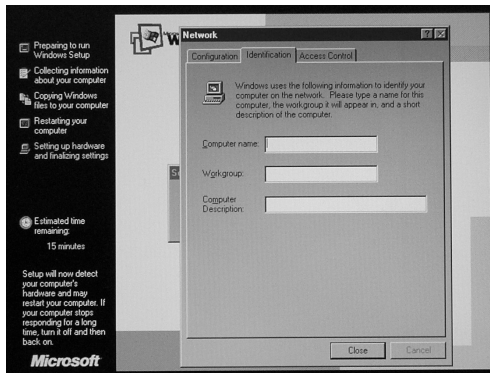

When using this unit in a network, ask the network manager about specifying a computer name and work group name.

After that, “Setting up hardware and finalizing settings” described below will be processed.

Making Windows Me Settings

Use the following procedure to make Windows Me settings required for installation after formatting the hard disk in the procedure above.

1. Input your user information.

- You must input your name, but input of the company name is optional. Pressing the **[Tab]** key after inputting your name causes the cursor to jump to the company name text box.

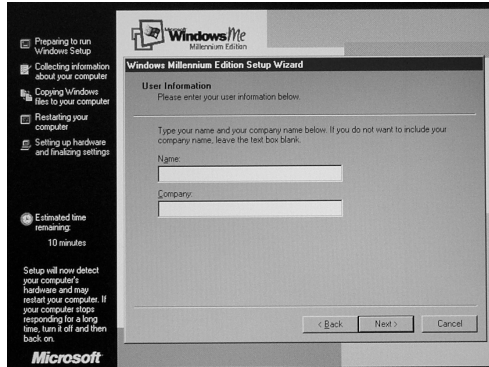

- After inputting your name and company name, click the **Next** button.

2. Read and agree to the Software License Agreement.

- Be sure you read the terms and conditions of the Microsoft Software End-user's License Agreement.
- To read all, use the **▲** or **▼** button, or **[PgUp]** (**[Fn]** + **[↑]**) or **[PgDn]** (**[Fn]** + **[↓]**) button to scroll the screen.

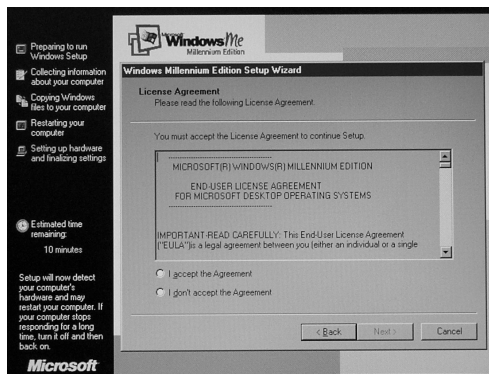

- Click the option button next to "I Accept the Agreement", and then click **Next**.

3. Input the Product Key number.

- Input the Product Key number that is printed on the Certificate of Authenticity affixed to the back of this unit, and then click **Next**. All the letters and numbers you type in this screen are automatically input in upper case, even if you do not press the **[Shift]** key.

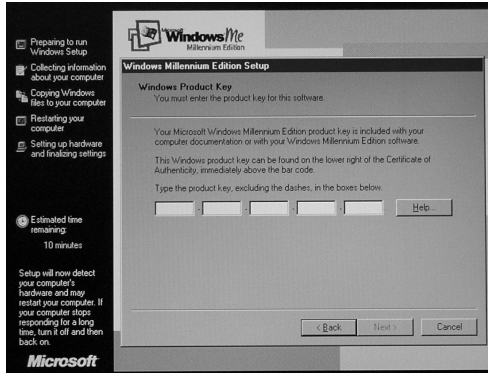

Make sure you input the Product Key number correctly. Take care that you distinguish between the letter O and the number 0 (zero).

- After you input the Product Key number, the Setup Wizard startup screen appears. Click the **Finish** button to continue.



- The Setup Wizard copies files from the CD-ROM and installs Windows Me.

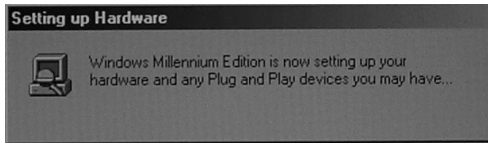

4. The screen changes to the “Windows is now setting up the following items.” screen from the Setup wizard.

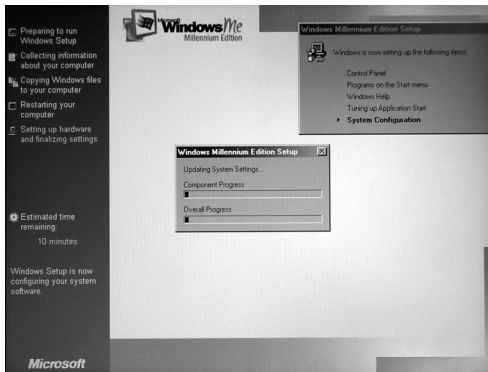
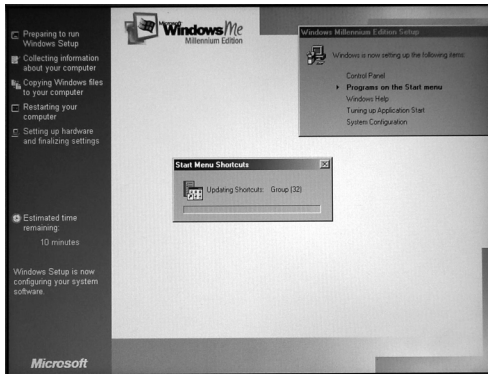

5. The setup is performed automatically and after that, the Windows Me restarts automatically.
6. Type in your user name and password.

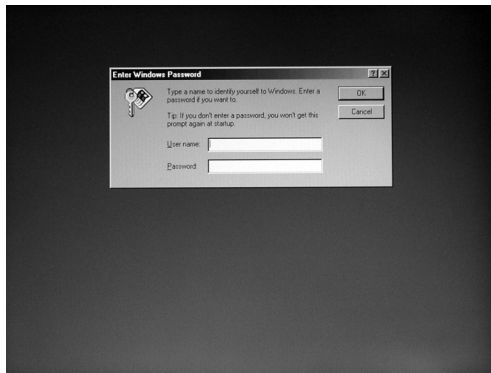

Type in your user name and password. If you do not input in the name and password, this screen will not appear when you start up Windows Me. Type the user name and then press **Tab** to move the cursor to the password text box. As you type your password, an asterisk appears in the textbox for every character you type. After you input the password, click the **OK** button.

Type your password once again into the “Confirm new password” box for confirmation. Once again, an asterisk appears in the textbox for every character you type. After you type in all the characters, click the **OK** button. You will need to input your user name and password each time you start up Windows Me.

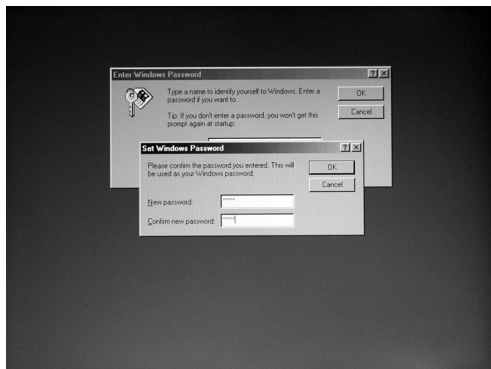

When the Windows Me starts up, the Welcome to Windows Me screen appears.

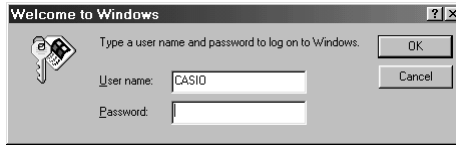

7. The Windows Me desk top screen appears.

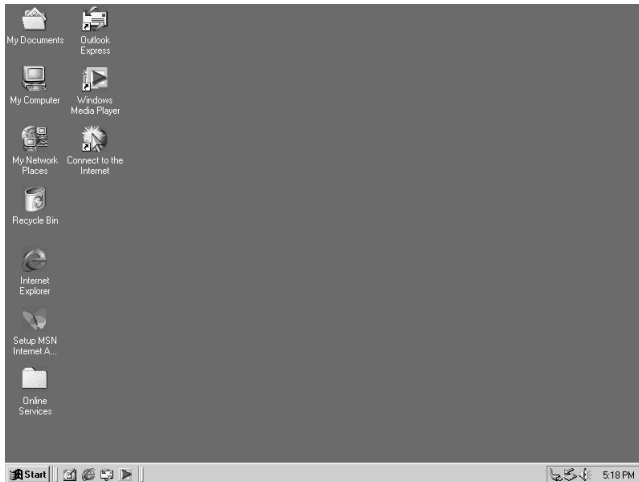

Next, perform the procedure below to change the BIOS setting. Otherwise, if you start up this unit with the MODE B setting of the software switch, Windows Me will start up as if the software switch is set to MODE A.

1. Shut down Windows Me and turn off the power of this unit.
2. Turn on the power of this unit.
3. While the CASIO logo is displayed, press **[F2]** a few times until the BIOS setup screen appears.
4. Press **[F9]** (SetUp Defaults) and confirm that Yes is selected, then press **[Enter]**.
5. Select **Main** by pressing **[→]**.
Select **Keyboard** by pressing **[↓]**, and then change Japanese to English by pressing the **space** key.
6. Press **[F10]** (Save and Exit) and confirm that Yes is selected, then press **[Enter]**.

Installing applications from the “Product Recovery CD-ROM”

Installing the CASIO Applications

Some applications are installed in this unit at the factory. The procedure you performed with the “Product Recovery CD-ROM” restores the hard disk to virtually the same state it was in when the FIVA shipped from the factory. Note, however, that the recovery procedure does not restore the following software and settings. The applications are not automatically installed from the “Product Recovery CD-ROM”. You need to start up the applications and then install them.

Setting/Software	Action Require to Restore	Page
Acrobat Reader/FIVA TOOL	Install from the Product Recovery CD-ROM.	116
Wallpaper and screen designs	Make Display Properties settings.	118
Windows Me Accessories	Install using Add/Remove Programs.	119

To install application from the Product Recovery CD-ROM

1. Insert the “Product Recovery CD-ROM” into the CD-ROM drive.
If you are continuing from installation of Windows Me, remove the “Microsoft Windows Me Operating System CD-ROM” and replace it with the “Product Recovery CD-ROM.”
2. Click **My Computer** and then **RECOVER...[D:]**.
3. The contents of the “Product Recovery CD-ROM” appear on the display. Open the folder for the application you want to install by double-clicking it.

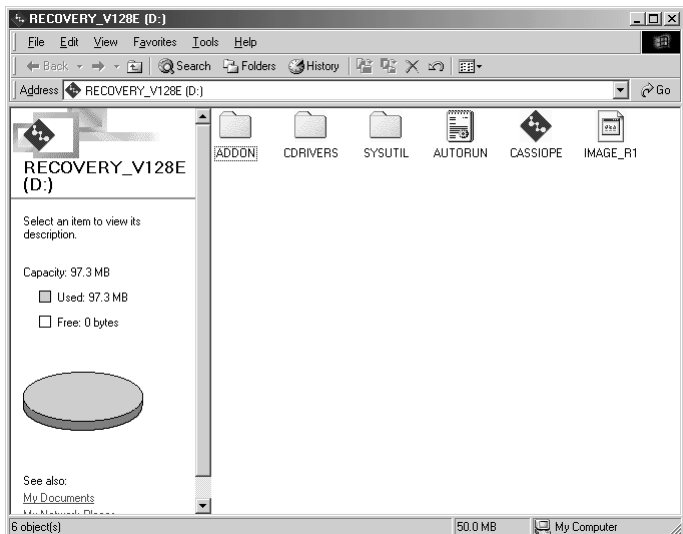

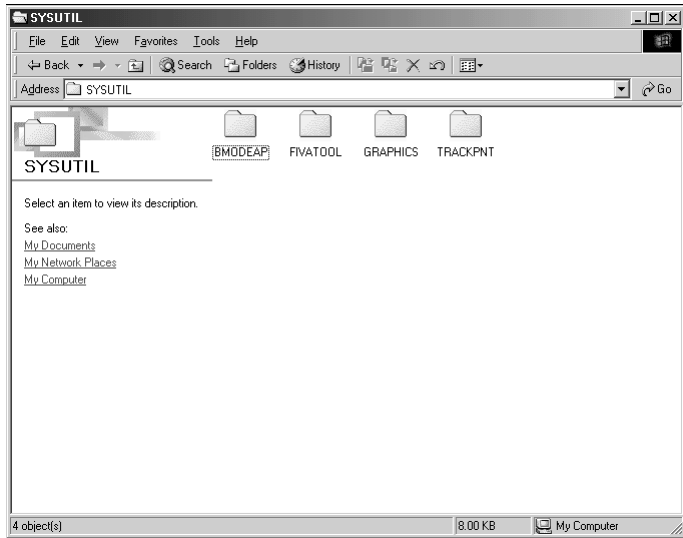

4. Double-click the **SETUP** icon or **AR405ENG.exe** in the folder you opened. This launches the installer for the application. Follow the instructions that appear on the screen.

FIVA TOOLS which includes Mobile Cockpit and other important system support utilities is strongly recommended to install.



Mobile Cockpit makes it easy to adjust speaker volume, change serial port functions, etc.

Making Screen Settings

Restoring the system causes the Windows Me display fonts and wallpaper to be set to initial default settings. Use the following procedure to change these settings.

1. Right-click on the Windows Me desktop.
2. From the menu that appears, select **Properties** to display Display Properties.

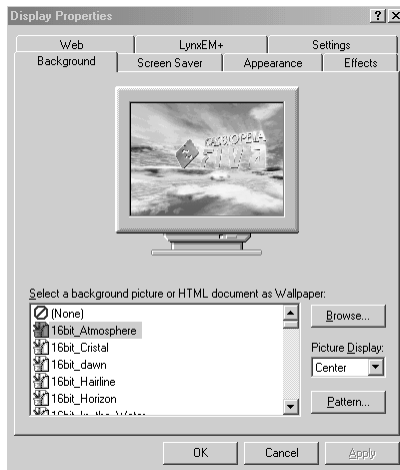

3. Select the wallpaper.
Click the **Background** tab, and select the desired picture from the **Wallpaper** list.
4. Click **OK** to close Display Properties.

Installing Microsoft Me Components

The components available after you install Microsoft Windows Me are different from those installed on FIVA when you purchase it. Use the following procedure to install the components that are available when you purchase FIVA.

1. Insert the “Microsoft Windows Me Operating System CD-ROM” into the CD-ROM drive.
2. On the Windows Me Taskbar, click **Start**, point to **Settings**, and then click **Control Panel**. Next, double-click the **Add/Remove Programs** icon.



3. Click the **Windows Setup** tab.

The names of components that are already installed have a checkmark next to them.

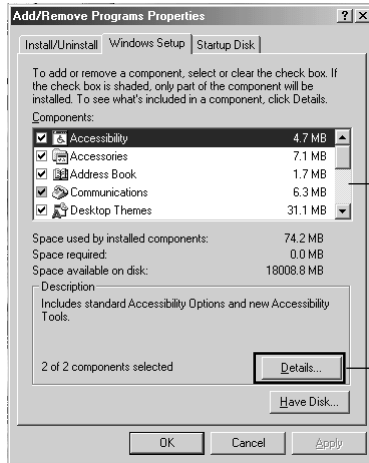

Select from this list.

Click here to specify which parts you want installed.

4. Select the components you want to install.

Select a component from the list, and then click the **Details** button. For FIVA, you should check all components in the list except for the following.

- **Multilanguage Support**
- Communications cable connection, dial-up server, and virtual private network

5. Start the installation.

Click **OK** to install the components you selected. It takes about 10 minutes to install the components. During that time, do not perform any other Windows Me operation. After a few moments a dialog asking whether you want to restart Windows Me appears. Click **Yes**.

Making a Startup Disk

A startup disk is a floppy diskette that contains the system files required to start up the system. It starts up the system without using the hard disk, so it comes in handy when you need to perform troubleshooting steps.

Important



The optional floppy disk drive is required to make a startup disk.

1. On the Windows Taskbar, click **Start**, point to **Settings**, and then click **Control Panel**.
2. Double-click the **Add/Remove Programs** icon.
3. In the Add/Remove Programs properties dialog, click the **Startup Disk** tab.
4. Insert a new 2HD (1.44Mbytes) into the floppy disk drive.
5. Click the **Create Disk** button to start creation of a startup disk.



Click here.

6. Specify where the startup disk files are located.
 - Specify the location of the **Cabs** folder if you have copied the Cabs files to your hard disk ([page 138](#)). The path should be: C:\Windows\Options\Cabs.
 - If you have not copied the Cabs files to your hard disk, you will need to connect the CD-ROM drive and insert the “Microsoft Windows Me Operating System CD-ROM” into the drive.
7. When the **Insert Disk** dialog appears, check to confirm that the floppy disk is inserted in the drive. Next, click **OK** to create the startup disk.

The following explanation on [pages 122 to 128](#) is about the Terminal Equipment embedded in CASSIOPEIA FIVA series and described by following the rules. The Terminal Equipment is operable and compliant with the regulations in the United States and Canada only.

For users of CASSIOPEIA FIVA series resident in other countries, the description and the instruction of the equipment are not applicable.

Using the Terminal Equipment FB1456VQL12 (built-in Modem)

For users in the United States

This equipment complies with Part 68 of the FCC rules. On the back side of this equipment is a label that contains, among other information, the FCC registration number and ringer equivalence number (REN) for this equipment. If requested, this information must be provided to the telephone company.

USOC Jack,RJ11C is available to this equipment.

An FCC compliant telephone cord and modular plug is provided with this equipment. This equipment is designed to be connected to the telephone network or premises wiring using a compatible modular jack which is Part 68 compliant. See Installation Instructions for details.

The REN is used to determine the quantity of devices which may be connected to the telephone line. Excessive RENs on the telephone line may result in the devices not ringing in response to an incoming call. In most, but not all areas, the sum of RENs should not exceed five (5.0). To be certain of the number of devices that may be connected to a line, as determined by the total RENs, contact the local telephone company.

If the terminal equipment FB1456VQL12 causes harm to the telephone network, the telephone company will notify you in advance that temporary discontinuance of service may be required. But if advance notice isn't practical, the telephone company will notify the customer as soon as possible. Also, you will be advised of your right to file a complaint with the FCC if you believe it is necessary.

The telephone company may make changes in its facilities, equipment, operations or procedures that could affect the operation of the equipment. If this happens the telephone company will provide advance notice in order for you to make necessary modifications to maintain uninterrupted service.

If trouble is experienced with this equipment FB1456VQL12, for repair or warranty information, please contact CASIO INC. (973.361.5400). If the equipment is causing harm to the telephone network, the telephone company may request that you disconnect the equipment until the problem is resolved.

This equipment cannot be used on public coin phone service provided by telephone company. Connection to party line service is subject to state tariffs. (Contact the state public utility commission, public service commission or corporation commission for information.)

The Telephone Consumer Protection Act of 1991 makes it unlawful for any person to use a computer or other electric device, including fax machines, to send any message unless such message clearly contains in a margin at the top or bottom of each transmitted page or on the first page of the transmission, the date and time it is sent and an identification of the business or other entity, or other individual sending the message and the telephone number of the sending machine or such business, other entity, or individual.

In order to program this information into your fax machine, you should see your FAX application software manual.

According to the FCC's electrical safety advisory, we recommend that you may install an AC surge arrester in the AC outlet to which this equipment is connected. Telephone companies report that electrical surges, typically lightning transients, are very destructive to customer terminal equipment connected to AC power source and that this is a major nationwide problem.

This equipment is registered with the FCC under Part 68 as a component device for use with CASIO COMPUTER CO., LTD. models CASSIOPEIA FIVA Series. In order for the FCC registration of this product to be retained, all other products used in conjunction with this product must also be FCC Part 68 registered for use with this host. If any of these components are not registered, then you are required to obtain FCC Part 68 registration of the assemblies equipment prior to connection to the telephone network. Part 68 registration requires that you maintain this approval and as such are responsible for the following:

Any component added to your equipment, whether it bears component registration or not, will require a Part 68 compliance evaluation. You may need to test and make a modification filing to the FCC before that new component can be used;

Any modification/update made by a manufacturer to any registered component within your equipment, will require a Part 68 compliance evaluation. You may need to test and make a modification filing to the FCC before that modified component can be used;

If you continue to produce this component you are required to comply with the FCC's Continuing Compliance requirements.

Therefore it is all recommended that only FCC Part 68 registered devices bearing the 'CN' or 'CE' equipment code as part of FCC registration number, be used. To determine if your particular component is appropriately approved, look for the FCC registration number on all components and ensure that the classification code '-CN-' or '-CE-' is part of that number. Refer to the FCC Registration number on this products as an example."

If the telephone company requests that you supply the FCC Registration number and REN of the device you are connecting, please supply the FCC Registration numbers from all component and host devices that have a direct PSTN connection (i.e. have an REN stated on the label) and the highest REN.

Notice Concerning FCC Redial Regulations

Note that federal law prohibits you from using software that is not in compliance with FCC rules that regulate redialing on the computer or other device where this modem is installed.

For users in Canada

NOTICE: The Industry Canada label identifies certified equipment. This certification means that the equipment meets telecommunications network protective, operational and safety requirements as prescribed in the appropriate Terminal Equipment Technical Requirements document(s). The Department does not guarantee the equipment will operate to the user's satisfaction.

Before installing this equipment, users should ensure that it is permissible to be connected to the facilities of the local telecommunications company. The equipment must also be installed using an acceptable method of connection. The customer should be aware that compliance with the above conditions may not prevent degradation of service in some situations.

Repairs to certified equipment should be coordinated by a representative designated by the supplier. Any repairs or alterations made by the user to this equipment, or equipment malfunctions, may give the telecommunications company cause to request the user to disconnect the equipment.

Users should ensure for their own protection that the electrical ground connections of the power utility, telephone lines and internal metallic water pipe system, if present, are connected together. This precaution may be particularly important in rural areas.

Caution: Users should not attempt to make such connections themselves, but should contact the appropriate electric inspection authority, or electrician, as appropriate.”

NOTICE: The **Ringer Equivalence Number** (REN) assigned to each terminal device provides an indication of the maximum number of terminals allowed to be connected to a telephone interface. The Termination on an interface may consist of any combination of devices subject only to the requirement that the sum of the Ringer Equivalence Numbers of all the devices does not exceed 5.”

The Ringer Equivalence Number of This terminal equipment is 0.3.

Main functions of the modem

Network control functions	Automatic Send and Receive by built-in NCU
Modem protocols	Conforms to the following protocols and possible to communicate in full duplex V.21/V.22bis/V.32/V.32bis/V.34/V34bis/V.90/K56flex/V.27ter/V.29/V.17
Data compression protocols	Conforms to MNP 5, ITU-T V.42bis
Error control protocols	Conforms to MNP 4, ITU-V.42

Function	Protocol	Speed	Comment
Data communication (Send and Receive)	ITU-T V.21	300	
	ITU-T V22bis	2400, 1200	
	ITU-T V32	9600, 4800	
	ITU-T V32bis	14400, 12000, 9600, 7200, 4800	
	ITU-T V34	33600, 31200, 28800, 26400, 24000, 21600, 19200, 16800, 14400, 12000, 9600, 7200, 4800, 2400	
Data communication (Receive only)	V.90	56000, 54667, 53333, 52000, 50667, 49333, 48000, 46667, 45333, 42667, 41333, 40000, 38667, 37333, 36000, 34667, 33333, 32000, 30667, 29333, 28000	
	K56flex	56000, 54000, 52000, 50000, 48000, 46000, 44000, 42000, 40000, 38000, 36000, 34000, 32000	
FAX communication	ITU-T V.27ter	4800, 2400	
	ITU-T V.29	9600, 7200	
	ITU-T V.17	14400, 12000, 9600, 7200	There are two modes, Long and Short in each speed respectively

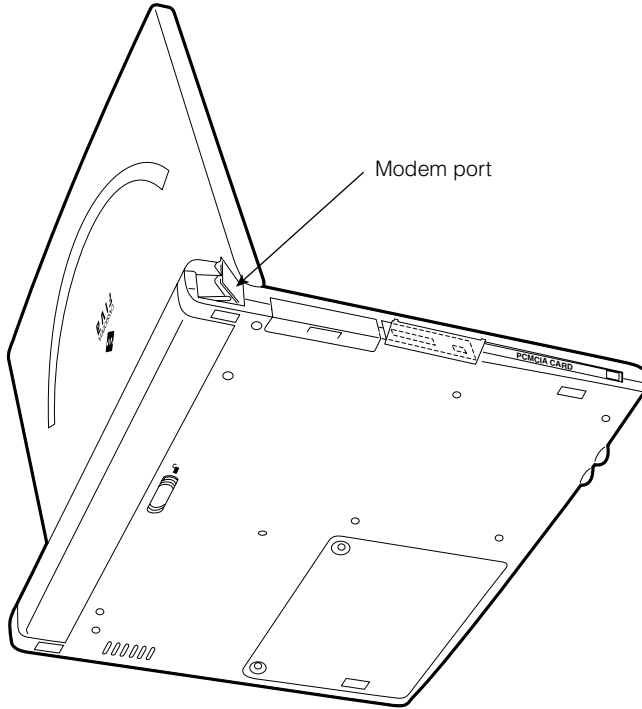

Connecting to telephone line

The modular cable that comes with the modem shall be used to connect the modem to the telephone line.

In this case, if the telephone line is available through the modular jack, it is possible to connect the modem to the telephone line directly.

Otherwise, an adapter is required or modification of the telephone line socket might be necessary.

Connecting to the FIVA

Turn off the power of the FIVA first and then connect as depicted below.

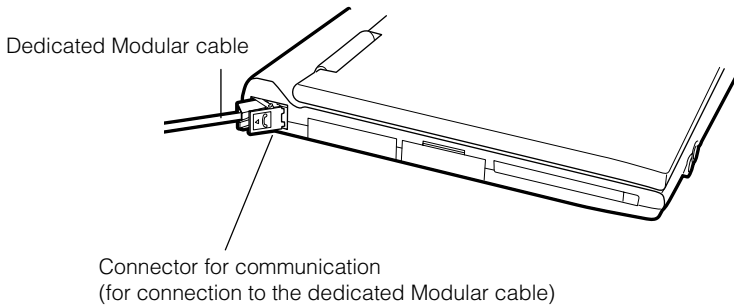

Caution on operation of the product

To use this product, operate as instructed below since this is designed to be embedded in the FIVA.

1. The product must be set in a case upon use.
2. Do not leave the product in the area such as hot and humid or exposed to direct sunlight since it is a precision product.
3. Do not spill any liquid such as water on the product.
4. Do not touch electronic terminals without discharging static fully otherwise it will cause damage.
5. In case the product is used exceeding the maximum specification, there is possibility that LSIs inside might be damaged permanently. Therefore, it is favorable to use the product under the normal operation conditions. If the product is left above the normal operating conditions, it might be possible to affect to the reliability of the LSIs.

Troubleshooting

This section describes what you should do whenever you start to experience problems with operation of FIVA, its peripherals, or applications you are running.

Basic Troubleshooting

Note the following important points whenever you are experiencing problems.

1. Take your time.

If the system seems to hang up, resist the urge to turn off power, click things on the display, or press keyboard keys. The operation you are performing may simply require a bit more time.

2. Take notes of information that appears on the display.

Message, numbers, and codes that appear on the display may provide hints to the cause of the problem and what you need to overcome it. Keep notes of such information when it appears on the display.

3. Try to determine the possible cause of the problem.

If FIVA is the source of the problem, or is it being caused by a peripheral or application? Does the same operation or condition always cause the same problem?

Is there something distinctive about the problem?

4. Check the documentation and on-line help.

You may be able to find information that leads to the solution of the problem in the documentation or on-line help of FIVA, its peripherals, or your applications.

System Outline

Have the following information handy whenever you request user support.

Memo about your system

FIVA	Model	
	Serial Number (on the bottom housing)	
	Memory Capacity(MB)	
	Hard Disk Capacity (GB)	
	Hard Disk Free Space (MB)	
	Battery Pack (Used/No Used)	
Peripherals	External Monitor	
	Printer	
	PC Card	
	Other Peripherals	
LAN	Used/No Used	
MODEM	Used/No Used	
Software	Windows Version All applications running when problem occurred	
Remarks		

Other information about FIVA can be found by visiting the CASSIOPEIA Website at: <http://world.casio.com/>

Power Supply

Symptom	Recommended Action
<p>Power does not turn on.</p> <ul style="list-style-type: none"> • Nothing happens when the power switch is turned on. • Power indicator lamp is flashing red. • Power turns on but immediately turns off. 	<p>Use the AC adaptor to power FIVA.</p> <ul style="list-style-type: none"> • Confirm that FIVA is connected to the AC adaptor, the AC adaptor is connected to the power cord and the power cord is connected to the power outlet securely. • Confirm that the battery pack is installed correctly. • Use a fully charged battery pack. If the battery pack has small charge when power is turned on, a warning message appears momentarily and power turns off.
<p>Power turns on, but the system does not start up.</p> <ul style="list-style-type: none"> • The system does not start up when power is turned on in the Hibernation Mode. 	<p>Leaving power turned on, press the RESET switch on the bottom of FIVA. Note that the RESET operation will result in loss of any data saved by the Hibernation Mode.</p>
<p>Display panel is open, but power does not turn on.</p>	<p>If the HDD indicator lamp is off, slide the power switch to turn on power.</p>
<p>Power turns off.</p> <ul style="list-style-type: none"> • FIVA suddenly goes into the Hibernation Mode and power turns off while you are using it. 	<p>Use the AC adaptor or a fully charged battery pack to power FIVA. A low battery pack can cause power to suddenly turn off.</p> <p>Wait for a while to allow the interior of FIVA to cool down. See the  at the bottom of this page.</p>
<p>Battery pack does not supply much operation time, even after a full charge.</p>	<p>Open the Mobile Cockpit Battery Report and check the battery inferior rate. When the BATTERY LIFE mark becomes red, replace the battery pack.</p>



For safety reasons, FIVA is designed so CPU Clock Speed slows down whenever internal temperature rises above a certain level. If operation continues, FIVA automatically enters the **Hibernation Mode**.

Display Problems

Symptom	Recommended Action
Nothing on the display, Power indicator lamp is not lit.	Slide the power switch to turn on power.
Display has gone blank.	Press the control button. FIVA's power saving function causes the display to go blank if no operation is performed for some time. See page 91.
The operator cannot remember the Windows Me password.	Input a new user name in the Windows Log On screen, or restore the system to its factory defaults.
The Start button or the Taskbar is not displayed.	When the Taskbar display is set to the low position. Move the pointer downward and when the shape of the pointer changes to the up and down arrow (↑↓), drag and drop in the upper direction. When the Taskbar display is set to the "Hide the Taskbar automatically". Remove the check in the checkbox next to the "Auto hide".
Display contents are difficult to see.	Reorient FIVA so you can view the display at a different angle.
Display is dim.	Use [Fn] + [F1] and [Fn] + [F2] to adjust display brightness. If the display remains dim at a bright setting, it may mean that it has reached the end of its service life. With your FIVA model number on hand, contact your original dealer or authorized distributor.
The monitor screen becomes dark temporarily.	When the external monitor connected to this unit is used, inserting the PCMCIA card (including the CF card) or updating the device driver with the System on the Control Panel may temporarily darken the monitor screen.
Nothing appears on the display.	Press [Fn] + [F10] to cycle through monitor functions until the display you want to use it selected. See page 67.

Software Problems

Symptom	Recommended Action
Cannot hear speaker output.	Is a pair of headphones plugged into FIVA? If so, unplug it. <ul style="list-style-type: none"> • Change the volume control setting. • Remove the check when the setting of “Volume control” is set to the “mute”.
Nothing comes out of the speaker, even when a pair of headphones is not plugged in.	Click the Mobile Cockpit Sound Volume icon and then use the slider to adjust speaker volume.
Sound output is too slow.	Turn off sound playback and then turn it back on again.
Sound output is broken.	Quit all other applications.
The sound skip or communication error occurs during playback or when the FIVA is in communication.	This may occur in the following cases. <ul style="list-style-type: none"> • When the power supply is switched between the AC adaptor and the battery pack while the FIVA is used. • When the battery control is open. • When too much load is taken in the CPU of the FIVA. • When the speed of CPU becomes slow because of high temperature inside the unit.
Occasional inability to record from the microphone or output sound from the speaker.	Change the volume control setting or re-start FIVA.
The one touch operation buttons do not function.	The “Mobile Cockpit II” activates the application function of the one touch operation buttons (P1: E-mail, P2: Internet, P3: Memo). Thus, directly after recovering from the Standby Mode or Hibernation Mode, or when there is no selected item, the one touch operation buttons may not function. In this case, press the appropriate button again or click on the screen.

Peripheral Operation Problems

Symptom	Recommended Action
Cannot use a PC/CF card.	Check to make sure the PC/CF card is inserted correctly into the PC/CF card slot.
The unit is locked when using the PC card or USB device.	If you set the unit to the Sleep Mode or Hibernation Mode while the device connected to the PC card is in use, the unit may lock up when recovering. To prevent data from being erased or the unit from unexpectedly malfunctioning, we recommend you to select the setting *** "Close all applications before entering Standby or Hibernation" *** .
<p>Cannot use the floppy disk drive.</p> <p>While a system startup disk is in the drive, the system cannot be restarted by Ctrl + Alt + Del. Pressing the reset switch and then pressing Ctrl + Alt + Del does not restart the system.</p>	The floppy disk drive may be defective. With your FIVA model number and FDD model number on hand, contact your original dealer or authorized distributor.
<p>Cannot use the floppy disk drive.</p> <p>The access lamp on the floppy disk drive does not go out.</p>	It may take considerable time to write large volume data to the disk. Wait until the access lamp goes out.
<p>Cannot use the floppy disk drive.</p> <p>The system cannot be started up from a floppy disk.</p>	Select FDD>HDD from the Preferences of the Settings in the Mobile Cockpit.
<p>After restoring from the Hibernation Mode, the connected USB-compatible device does not work.</p>	<ul style="list-style-type: none"> • Check that the cables are connected correctly. • Disconnect the USB cable and then connect it again.

Text Input Problems

Symptom	Recommended Action
The keyboard is shift locked.	Press Shift + Caps Lock to shift lock the keyboard between upper case and lower case characters.
Nothing happens when keyboard keys are pressed.	Turn FIVA power off and then back on again.
Nothing happens when the Power switch is turned on.	Press Ctrl + Alt + Del .
Nothing happens when Ctrl + Alt + Del are pressed.	Press the RESET switch. See page 24.
Typing letter keys inputs numbers.	Press Fn + F11 to turn off number lock.

Printing Problems

Symptom	Recommended Action
Cannot print. Cause: Printer power is not turned on.	Turn off FIVA power. Next, turn on the printer and then turn on FIVA.
Cannot print. Cause: Cable or connectors are not connected properly.	Make sure that all connections are secure and correct. Also make sure that you are using the specified printer cable.
Cannot print. Cause: Printer is not on line mode.	Put the printer on line mode.
Cannot print. Cause: The printer specified in the application you are printing from is different from the printer you are using.	Open the Printers window from Control Panel and select the correct printer.
Still cannot print, even after taking the actions described above.	Shut down Windows Me and then restart.
Cannot print. Cause: The printer driver required by the printer you are using is not installed.	Install the proper printer driver. You must install the proper printer driver before you can use the printer for the first time.

General Operation Problems

Symptom	Recommended Action
Power indicator lamp flashes red immediately after charging the battery pack.	Purchase a new battery pack and replace the current one. Battery packs tend to lose their ability to charge after long use.
FIVA suddenly hangs up.	<ul style="list-style-type: none">• If you suspect that the problem is due to low battery power, connect the AC adaptor and charge the battery.• If you suspect that the problem is being caused by the application you are using, press the RESET switch and restart Windows Me.
System runs too slow (1).	<ul style="list-style-type: none">• Try turning power off and then back on again.• Memory may be low, which means you have to increase it by installing a separately available expansion memory board.
System runs too slow (2).	When the Power Management is set to the Economy Mode, set to the Normal Mode or the Full power Mode. See page 87 .
System runs too slow (3).	Turn power off and wait for a while. Normal operation should return after FIVA has a chance to cool down.
Displayed date and time are wrong.	<ul style="list-style-type: none">• Use the Control Panel to set the correct date and time.• If the date and time seem to require frequent setting, it may mean that the clock battery is low. Contact your original dealer or authorized distributor about having the clock battery replaced.

General Operation Problems (continued)

Symptom	Recommended Action
Hot keys do not work.	Click the Taskbar's Start button and start up Mobile Cockpit from the Programs menu.
Mobile Cockpit is not displayed.	<ul style="list-style-type: none"> • If Mobile Cockpit is not running, click the Taskbar's Start button and start up Mobile Cockpit from the Programs menu. • If the Mobile Cockpit toolbar is hidden, click the Mobile Cockpit icon on the Taskbar and then uncheck the Hide option on the menu that appears.
The pointer does not move.	<ul style="list-style-type: none"> • Press Ctrl + Alt + Del to restart the system. • If Ctrl + Alt + Del does not work, press the RESET switch and then restart the system.
Windows Me is hung up.	<ul style="list-style-type: none"> • Press Ctrl + Alt + Del, and then click the Shutdown button. Next, restart Windows Me. • If Ctrl + Alt + Del does not work, press the RESET switch and then restart the system.
The Fn + F7 mute function fails to operate when pressed.	The Fn + F7 mute function may not operate while "Windows Media Player" is in function. During this state, information on the task tray, the master volume and the performance will not coincide with each other.

Problems Following Restoration of the System

Symptom	Recommended Action
Standard bundled applications do not work.	Some of the bundled applications are not re-installed when you restore the system. Use the "Product Recovery CD-ROM" to reinstall all the applications.
Screen fonts are too small.	Use Display Properties to change display font size settings.
Wallpaper is different.	Use Display Properties to change the wallpaper setting.

FIVA Malfunction

Symptom	Recommended Action
FIVA is emitting smoke and heat.	Immediately turn off power and unplug the AC adaptor from the wall outlet.
You don't know what to do.	Contact your authorized distributor. Have the following information on hand. <ul style="list-style-type: none">• Product name and model number• Date of purchase• Current status and the names of applications being used
FIVA malfunction	Contact your original dealer or authorized distributor. Have the following information on hand. <ul style="list-style-type: none">• Product name and model number• Date of purchase• Current status and the names of applications being used

Specifications

Model		MPC-205E	MPC-206E
CPU		Transmeta Crusoe TM5600 500MHz	Transmeta Crusoe TM5600 600MHz
Built-in Cache Memory		128KB (1), 512KB (2)	
BIOS ROM		512KB	
Memory	Standard/Max.	96MB/192MB	128MB/192MB
	Slot	1 expansion slot	
VRAM		2MB (SMI LynxEM+)	
Monitor Functions	Monitor Device*1	8.4-inch TFT color LCD	
	Resolution	SVGA (800 × 600 dots), 16,770,000 colors max.	
Input Device	Keyboard	Built-in 80-key keyboard; hot keys (with [Fn] key), Windows/application keys, 16mm × 13mm (0.63" × 0.51") pitch, 1.5mm stroke	
	Operation buttons	One touch operation buttons (E-mail, Internet, Memo)	
	Pointing device	Stick	
Hard Disk		10GB	20GB
Sound Functions		Monaural speaker (built-in)	
		Headphones (stereo mini jack)	
		Monaural microphone (built-in)	
Interfaces	LAN	10Base-T/100Base-TX	
	IEEE1394	× 1	
	USB*2	× 1 (Connect the floppy disk drive such as MPC-240FDD, etc.)	
	RGB	× 1	
PC Card Slot*2		Type II × 1 slot (Connect the CD-ROM drive such as MPC-142CDD, etc.)	
CF Card Slot		Type I/II × 1 slot	
Power Management		Auto or manual setting	
Timekeeping		Clock battery backup	
Security		Power on password	

Power Requirements	Input	DC16V from AC adaptor (Input: 100V~240V AC, 50/60Hz)
		Lithium-ion battery, equipped as standard
Battery Capacity*3		Standard Battery Pack: Approximately 4.5 hours
		Large-capacity Battery Pack*2: Approximately 9 hours
Battery Charge Time*3		Power On: Approximately 2.5 hours (5 hours with Large-capacity Battery Pack)
		Power Off: Approximately 2.5 hours (5 hours with Large-capacity Battery Pack)
Dimensions with standard battery pack		223 (W) × 197.3 (D) × 21.2 (24.6) (H) mm (8.78"(W) × 7.77"(D) × 0.84"(H))
Approximate weight with standard battery pack		990g (2.18lb)
Standard battery pack dimensions		204 (W) × 41 (D) × 24.6 (H) mm 8.03"(W) × 1.62"(D) × 0.97"(H)
Standard battery pack approx. weight		165 g (0.36lb)
Operating Environment		Temperature: 5°C to 35°C (41°F to 95°F); Humidity: 30 to 80% (non-condensation)

*1 Though the FIVA TFT LCD is a very high quality display device, there may be times that brightness is uneven and when fine specs appear on the screen. Also, some dots may not illuminate or some dots may stay illuminated at all times. All of this common for liquid crystal displays, and does not indicate malfunction.

*2 The large-capacity battery pack (MPC-274LBAT), the floppy disk drive (MPC-240FDD), and the CD-ROM drive (MPC-142CDD) are the optionally available accessories.

*3 Battery pack is consumable.

Actual times differ according to operating conditions and the type of options connected. The time indicated above has been measured using a new battery pack.

Options List

The useful options shown below are available for use with the FIVA MPC-205E/206E.

Memory Expansion DIMM Board

(Product No. MPC-252RAM) 64MB
MPC-253RAM) 128MB

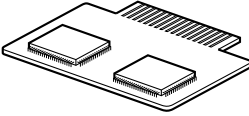

AC Adaptor

(Product No. MPC-277ADPE)

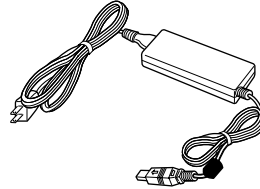

Floppy Disk Drive

(Product No. MPC-240FDD)

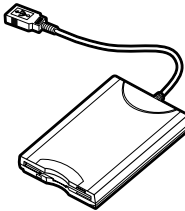

CD-ROM Drive

(Product No. MPC-142CDD)

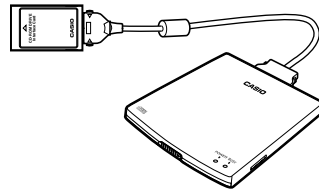

Large-capacity Battery Pack

(Product No. MPC-274LBAT)

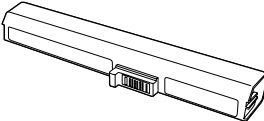

Battery Pack

(Product No. MPC-273BAT)

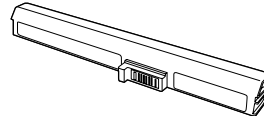

FIVA User's Guide

(Product Nos.: MPC-205E/206E)

1st. ed. 2001-04

CASIO COMPUTER CO., LTD.

6-2, Hon-machi 1-chome
Shibuya-ku, Tokyo 151-8543, Japan

Notes

- This guide cannot be reproduced or duplicated in any form, in part or in whole, without written permission from CASIO COMPUTER CO., LTD.
- The content of this guide is subject to change without notice.
- CASIO has, to the best of its ability, endeavored to make this guide as accurate as possible. However, if any unclear portions or omissions are found, please contact your dealer.

Descriptions and specifications furnished herein the User's Guide by CASIO Computer Co., Ltd. are believed to be accurate and reliable. However, CASIO reserves the right to make changes or improvements in the descriptions and specifications without any advanced notice. CASIO does not assume any liability arising from the use of the contents, nor for any infringements of patents or other rights of third parties which may result from the use of the contents.



CASSIOPEIA
71V2

CASIO COMPUTER CO., LTD.

6-2, Hon-machi 1-chome
Shibuya-ku, Tokyo 151-8543, Japan

Printed on recycled paper.
Printed in Taiwan