

contents

Chapter 1. Getting to know your Device	07
1.1 Getting Started	10
1.2 Status Indicators	12
1.3 Entering Information	13
Chapter 2. Personalising your phone	19
2.1 Today Screen	20
2.2 Start Menu	22
2.3 Ring Tone and Notification	23
2.4 General Settings	26
2.5 Security	34
Chapter 3. Using your phone	37
3.1 Making a Call	38
3.2 Receiving a Call	41
3.3 In-Call Options	42
3.4 Special Dialing Requirements	43
3.5 Additional Settings	43
Chapter 4. Getting connected	47
4.1 Automatic setup of your data connections	48
4.2 Manual setup of your data connections	48
4.3 Bluetooth	51
4.4 Beams	56
4.5 Connecting to a Wireless LAN	58

Chapter 5.Messaging	63
5.1 Text messaging	64
5.2 Email	68
5.3 MMS	78
5.4 Pocket MSN	84
Chapter 6.Synchronizing	93
6.1 Introduction to ActiveSync	94
6.2 Installing and Configuring ActiveSync	94
Chapter 7.Applications & Multimedia	107
7.1 Contacts	108
7.2 Calendar	110
7.3 Tasks	113
7.4 Camera & Video Recorder	115
7.5 Using Pictures & Videos	119
7.6 Using Windows Media Player	124
7.7 Internet Explorer Mobile	131
7.8 Using JAVA	136
7.9 Wireless Manager	139
7.10 Notes	141
7.11 Word Mobile	142
7.12 Wireless Manager	144
7.13 Viewing Slide Shows with PowerPoint Mobile	148
7.14 Internet Sharing	149
7.15 Using Terminal Services Client	151
7.16 File Explorer	152
7.17 Adding more programs to your device	153

Chapter 8.Maintaining you phone	155
8.1 Maintaining your phone	156
8.2 Resetting your Phone	157
8.3 Installing your SIM card	158
8.4 Managing Programs Memory	159
Appendix.Other Applications	161
A.1 Battery Information	162
A.2 PC Requirement to Run ActiveSync 4.2	163
A.3 Regulatory Notices	164
A.4 Specifications	169

Copyright © 2006 i-mate. All Rights reserved.

No part of this manual, including the product and software described in it, may be reproduced, transmitted, stored in a retrieval system, or translated into any language in any form, by any means, without prior written permission from i-mate.

i-mate provides this publication “as is” without warranty of any kind. This information could include technical inaccuracies or typographical errors. i-mate may make improvements and/or changes in the product. Information and specifications contained in this document are subject to change at any time without notice.

The information contained in this document does not affect or change the product specifications or warranties. i-mate is not liable for any damages resulting from the use of this product.

IMPORTANT SAFETY INFORMATION

Please read the following information carefully before you start using your device to avoid any damages caused by improper usage:

- The device is not charged when you take it out of the box. The battery should be charged for at least 8 hours before first use. Do not remove the battery while charging.
- Do not use batteries, which have not been specified by the manufacturer, as this may cause leakage or rupture.
- Do not change the battery with an unspecified AC Adapter, as this may cause damage to both the device and the battery.

- When discarding the batteries, dispose of them in a proper manner, according to the battery manufacturer's instructions and your local laws.
- Power off the device and remove the battery before inserting the SIM card. Make sure the SIM card snaps correctly into the SIM socket.
- Do not open or tamper with the device cover as it will void your warranty.
- Do not press hard on this product, as it may cause damage to the screen or the internal components.
- Do not use the device at gas or refuelling stations, chemical plants and places containing explosives or flammable materials.
- Do not strike, shake or heat the device in a way which may cause battery leakage or rupture and damage to the device.
- Do not scratch the screen with hard objects.
- Do not clean the screen with chemical detergents. Only use cloths, specifically designed for cleaning liquid displays, to wipe the screen.
- Do not expose the device to direct sunlight, or leave the device in a humid environment, for extended periods of time, as this may cause damage to the device and battery.
- Do not immerse the device in water.
- The device may interfere with the navigation and/ or communication systems on aircraft. The use of the device on aircraft is prohibited by laws in most countries.
- Use hands-free devices, if you need to use the telephony services, while driving a vehicle.

Interference with Medical Equipment Functions

This product may cause medical equipment to malfunction. The use of this device is forbidden in most hospitals and medical clinics.

Non-ionizing Radiation

This product should be operated in the suggested normal condition only to ensure the radiative performance and safety of the interference. As with other mobile radio transmitting equipment, users are advised that for satisfactory operation of the equipment and for the safety of personnel, it is recommended that no part of the human body be allowed to come too close to the antenna during operation of the equipment.

Trademark Information

Microsoft, MS-DOS, Windows, Windows NT, Windows Server, Windows Mobile, ActiveSync, Excel, Internet Explorer, MSN, Outlook, PowerPoint and Word are either registered trademarks or trademarks of Microsoft Corporation in the United States and/or other countries.

Chapter 1.

Getting to Know Your Device

- 1.1 Getting Started
- 1.2 Status Indicators
- 1.3 Entering Information

Device View

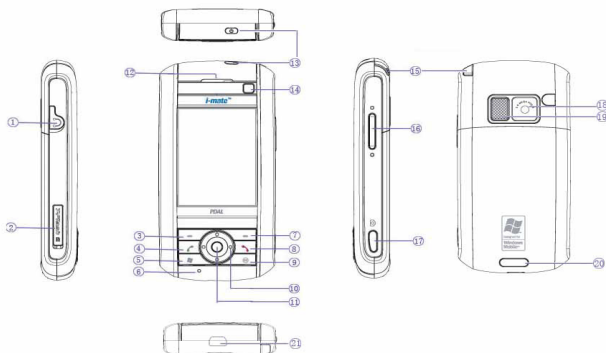

No.	Item	Function
1.	Earphone Jack	Allows you to listen to audio media or use the phone's hands-free kit.
2.	MicroSD Card Slot	Lets you insert a storage card for storing data.
3.	Left SOFT KEY	Performs the command shown in the label above the button.
4.	TALK Button	Press to answer an incoming call or dial a number.
5.	START menu KEY	Press to display your START menu.
6.	Microphone	Speak into the microphone when receiving or making a phone call or voice recording.
7.	Right SOFT KEY	Performs the command shown in the label above the button.
8.	END Button	Press to end the phone call.
9.	OK Button	Press to confirm your data entries or exit the program in use.



No.	Item	Function
10.	Navigation Pad	Press this multi-directional control up, down, left, or right to move through menus, program instructions.
11.	Centre Button	Carry out the selection from the Navigation pad scrolling by pressing the center button.
12.	Earpiece	For use during phone calls.
13.	Power on/off button	Press to turn off your device temporarily and switches the device to sleep mode; press and hold (4 seconds) to turn off your device completely. When your device is in sleep mode, you can still use the phone function to receive calls; however, the phone function is off when you turn off the device completely.
14.	Messaging	Press to open the Messaging application. Illuminates when message (s) received.
15.	Stylus	Use the stylus to write, draw, or select items on the touch screen.
16.	Volume Controller	Scroll up or down to adjust the volume.
17.	CAMERA Button	Press to launch the camera. Press again to take a picture.
18.	Camera Lens	Used for capturing photos and videos.
19.	External Speaker	Allows you to listen to audio media for hands-free calls.
20.	Cover Latch	Slide this latch to release the battery cover.
21.	Sync Connector	Use this connector for synchronizing data or recharging the battery.
22.	Reset Button	To soft reset the device.

1.1 Getting Started

To turn ON the device, press and hold the POWER button for 4 seconds. When you turn on the device for the first time, you are asked to complete a screen calibration process. Calibrating the device screen involves tapping the center of a cross with the stylus as the cross moves around the screen. This process ensures that when you tap the screen with your stylus, the tapped item is activated.

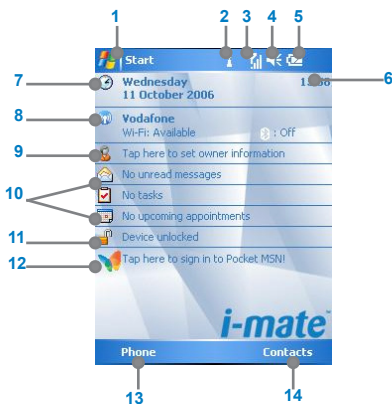
The Today screen displays important information, such as upcoming appointments and status indicators. You can tap a section on the screen to open the associated program. If at any point you need to access the Today Screen, just press/tap Start > Today.





























1. Tap to open the Start menu.
2. Tap to view connectivity status.
3. Indicates the radio signal strength. Tap to configure the phone settings.
4. Tap to control device/ringer volume level.
5. Indicates the battery status. Tap to open the Power Settings screen
6. Displays the current time.
7. Displays the current date. Tap to setup date, time, alarm, and more.
8. Tap to start Wireless Manager; it also shows status of WiFi (left) and Bluetooth (right)  interfaces
9. Tap to set owner information
10. Your day at a glance with reminders. Tap to open the related program: messages, tasks, and appointments.
11. Tap to lock or unlock the device. : locked; : unlocked
12. Tap to open the MSN sign-in screen
13. Tap to open the Phone screen.
14. Tap to open Contacts screen.

To completely turn OFF your device press and hold the POWER button for 10 seconds. A single quick press of the POWER button will set your device into Sleep mode. In Sleep mode you can still use the phone function to receive calls. In order to save battery, your device will automatically go into sleep mode if not used for a period of time.

1.2 Status Indicators

Following are some of the status icons that you may see on your device.

Icon	Description	Icon	Description
	Indicates the battery is fully charged.		No phone service.
	Indicates the battery is very low.		Searching for phone service.
	Battery charging.		Voice call in progress.
	Sound on.		Calls are forwarded.
	Sound off.		Call on hold.
	Ringer in vibration mode.		Missed call.
	Connection is active.		GPRS is in use
	Connection is not active.		New e-mail or text messages.
	Synchronization in progress.		There are more notifications. Tap the icon to view all.
	Synchronization error.		Indicates Wi-Fi is turned on.
	Indicates maximum signal strength.		Indicates the device is locked. : Device unlocked.
	No signal.		WiFi is connected
	Phone is turned off.		WiFi data call



1.3 Entering Information

Input Panel

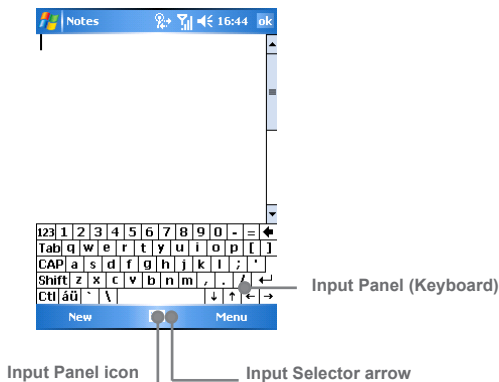
Input Panel provides access to the various input methods available on your device, including Block Recognizer, Keyboard, Letter Recognizer, and Transcriber. By default, the Input Panel icon appears on the menu bar to indicate which input method is currently selected. The Input Selector arrow (shown at the right side of the Input Panel icon) opens a list of available input methods.



The following input methods are available when text entry is possible.

Icon	Input method
	The on-screen keyboard.
	Letter Recognizer or Block Recognizer.
	Transcriber

With the **on-screen Keyboard** you can enter text by tapping keys on the keyboard displayed on the screen. To enlarge the on-screen Keyboard tap the Input Selector arrow, then tap Options, in the Input method list, select Keyboard and then Tap Large Keys. By default, when the Small keyboard is selected, you can use gestures for the following characters:



With **Letter Recognizer** (only available when text entry is possible), you can write individual letters, numbers, and punctuation, which are then converted into typed text. To use Letter Recognizer:

1. From a program, tap the Input Selector arrow, and tap Letter Recognizer.
2. Write characters, numbers, and symbols in the designated writing area.
 - Enter capital letters by writing in the ABC (left) area of the box.
 - Enter lower case letters by writing in the abc (middle) area of the box.
 - Enter numbers by writing in the 123 (right) area of the box.
 - Enter punctuation and symbols by tapping in either area of the box and then writing the desired character.



For help with writing characters with Letter Recognizer, tap the question mark near the writing area.

With **Block Recognizer**, you use a single stroke to write letters, numbers, symbols, and punctuation, which are then converted into typed text. To use Block Recognizer





1. From a program, tap the Input Selector arrow, and tap Block Recognizer.
2. Write characters, numbers, and symbols in the designated writing area.





- Enter letters by writing in the abc (left) area of the box.
- Enter numbers by writing in the 123 (right) area of the box.
- Enter symbols and punctuation by tapping in either area of the box and then writing the desired character.

Transcriber is a handwriting recognition program that allows you to write in cursive, print, or a combination of both. Transcriber works transparently in the background of programs, recognizing words with its integrated dictionary. When Transcriber is turned on, it interprets stylus movement anywhere on the screen as handwriting input. For more information about using Transcriber, see Help on your device. To use Transcriber:





1. Start a program that accepts user input, such as Word Mobile.
2. Tap the Input Selector arrow, and tap Transcriber. The Transcriber introductory screen appears.
3. In a program, position the cursor where you want text to appear.
4. Use the stylus to write anywhere on the screen. The handwriting will be converted to text shortly after you lift the stylus from the screen.





Use quick strokes of the stylus to edit your text or to insert returns, spaces, or tabs:

Do	To
	Insert a paragraph return at the cursor. The horizontal portion of the gesture must be at least two times longer than the vertical portion.
	Insert a space at the cursor. The horizontal portion of the gesture must be at least two times longer than the vertical portion.
	Move the cursor one space back and erase any text. Do the gesture by drawing a line from right to left.
	Open the menu of alternate words if a word is selected or the on-screen Transcriber keyboard if no text is selected. Do the gesture by drawing a line straight down and back up.

	Change the capitalization of a selected letter, word, or block of text. Do the gesture by drawing a line straight up.
	Undo the last action. Do the gesture by drawing a line straight up and back down.
	Copy the selected text. Do the gesture by drawing a line from left to right and back.
	Cut the selected text. Do the gesture by drawing a line from right to left and back.
	Paste copied or cut text. Do the gesture by drawing a line from the lower left of the screen diagonally up toward the right and back down to the right.

The Transcriber toolbar, which appears at the bottom of the screen when Transcriber is open, provides easy access to several tools, Enter, Space, and Backspace buttons, and Left and Right arrow buttons.

Tap	To
	Open the Options dialog box, where you can set options such as writing direction, text entry, and shorthand.
	Open Letter Shapes, where you can set your personal writing styles to maximize recognition.
	Use the miniature keyboard to quickly enter numbers, punctuation, and other symbols.
	Change the character recognition mode. <ul style="list-style-type: none"> • a mode. This is the default for optimum handwriting recognition. • 123 mode. Numbers and some letters are allowed and the calculator is activated. • A mode. All letters are automatically capitalized. If you are in A or 123 mode, recognition returns automatically to the default mode once you lift the stylus.
	Insert a space at the cursor.

	Insert a paragraph return at the cursor.
	Move the cursor one space to the left.
	Move the cursor one space to the right.
	Move the cursor one space back and erase any text.
	Open Transcriber Help.

Drawing and Writing on the Screen

With your device, you can draw directly on the screen, or write on the screen and save notes (Start > Programs > Notes) in your own handwriting. To do this, you must set the input mode in Notes to Writing. If you prefer to use handwriting or frequently add drawings to your notes, you may find it helpful to set Writing as the default input mode. If you prefer typed text, set Typing as the default input mode.

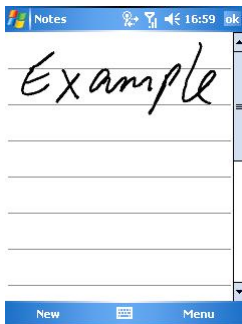

Drawing on the Screen

To change the default input mode in Notes, tap Menu > Options in the notes list and then, in the Default mode box, tap either Writing or Typing depending on your personal preferences. Then Tap OK.

Voice Recording

You can create a stand-alone recording (voice note) or you can add a recording to a note. To create a voice note

1. Tap Start > Programs > Notes.
2. Do one of the following:
3. To create a stand-alone recording, record from the note list.
4. To add a recording to a note, create or open a note.
5. If you do not see the Recording toolbar, tap Menu > View Recording Toolbar.
6. Tap the record icon (●) to begin recording.
7. Hold your device's microphone near your mouth or other source of sound.
8. Tap the stop icon (■) when finished recording.
9. If you adding a recording to a note, tap OK to return to the note list when finished.
10. If you are recording in an open note, an icon will appear in the note.
11. If you are creating a stand-alone recording, the recording will appear in the note list.

To change recording formats

1. Tap Start > Settings > Personal tab > Input.
2. Tap the Options tab, and in the Voice recording format list, tap the format you want.
3. Tap OK.

Chapter 2.

Personalising your phone

- 2.1 Today Screen
- 2.2 Start Menu
- 2.3 Ring Tone and Notification
- 2.4 General Settings
- 2.5 Security

2.1 Today Screen

The Today screen shows your upcoming appointments, active tasks, and information about e-mail messages.

You can customize the items and background presented in the Today screen on your device:

1. Tap Start > Settings > Personal tab > Today.
2. On the Appearance tab, select the desired theme for the background of the Today screen. You can use one of your own pictures as the background image on the Today screen selecting “Use this picture as the background” check box, and tap Browse to view a list of your picture files.
3. On the Items tab, select the items you want to appear on the Today screen. To change the order of items displayed on the Today screen, tap the item, and then tap Move Up or Move Down.
4. Tap OK.

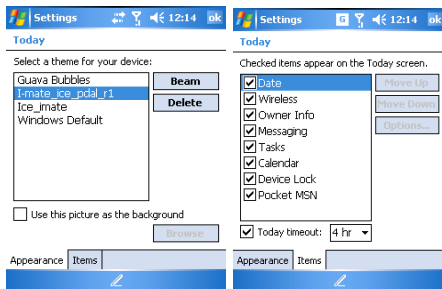

You can also customize the presentation of the upcoming Appointments in the Today Screen:

1. Tap Start > Settings > Personal tab > Today.
2. Tap the Items tab.



3. Select Calendar and tap Options.
4. Do any of the following:
 - Select Next appointment to show only the next appointment in your schedule, or Upcoming appointments to show multiple appointments.
 - Clear the Display all day events check box if you do not want to display all-day events.

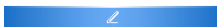
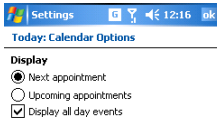

If you have a large number of tasks, you may want to specify the kind of tasks that are displayed on the Today screen. To set options for displaying tasks on the Today screen:

1. Tap Start > Settings > Personal tab > Today.
2. Tap the Items tab.
3. Select Tasks and tap Options.
4. Do any of the following:
 - Under Display number of, select the type of tasks you want to appear on the Today screen.
 - In the Category list, select whether to display only tasks assigned to a specific category or to display all tasks.

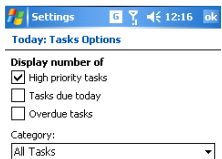

Entering and displaying owner information in the Today Screen are best practices; they allow someone to return the device to you in case it is lost.

1. Tap Start > Settings > Personal tab > Owner Information.
2. On the Identification tab, enter your personal information.



If owner information is displayed on the Today screen, you can open and edit the information directly from the Today screen. Just tap that section of the screen.

2.2 Start Menu

The Start menu, located at the top left corner of the Today screen, displays a list of programs. It lets you close a screen and switch from one program to another. You can start a program by scrolling through the programs list and then pressing ENTER, or by tapping a program with the stylus.

1. You can choose which items appear in the Start menu:
2. Tap Start > Settings > Personal tab > Menus.
3. Select the check boxes of the items you want to appear in the Start menu. You can select up to seven items.



You can also create folders and shortcuts to appear on the Start menu. In ActiveSync on your PC, click Explore. In the Mobile Device window, double-click My Windows Mobile-Based Device > Windows > Start Menu, then create the folders and shortcuts that you want. You will see the added items after you synchronize.

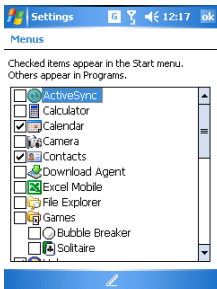

2.3 Ring Tone and Notifications

To change the ring tone

1. From the Phone keypad, tap Menu > Options > Phone tab.
2. In the Ring tone list, tap the sound you want to use.



To use custom *.wav, *.mid, *.mp3, or *.wma files as ring tones, use ActiveSync on your PC to copy the file to the /Windows/Rings folder on your device. Then, select the sound from the Ring tone list. For more information about copying files to your device, see ActiveSync Help on your PC.

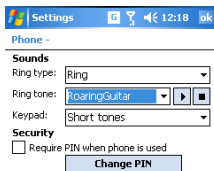

Changing the ring tone

It is also possible to assign a specific Ring Tone for a Contact:

1. Go to Start > Contacts and Tap on the desired Contact.
2. Select Menu > Edit
3. In the Ring tone field, select a ring tone of your choice.

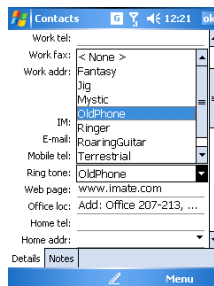

Changing the ring tone for a specific Contact

To change the ring type

You can change the way that you are notified of incoming calls. For example, you can choose to be notified by a ring, a vibration, or a combination of both.



1. From the Phone keypad, tap Menu > Options > Phone tab.
2. In the Ring type list, tap the desired option.

To set an alarm

1. Tap Start > Settings > System tab > Clock & Alarms > Alarms tab.
2. Tap <Description> and enter a name for the alarm.
3. Tap the day of the week for the alarm. You can select multiple days by tapping each desired day.
4. Tap the time to open a clock and set the time for the alarm.
5. Tap the alarm icon (🔔) to specify the type of alarm you want. You can choose a flashing light, a single sound, a repeating sound, or vibration.
6. If you choose to play a sound, tap the list next to the Play sound check box and tap the sound you want.

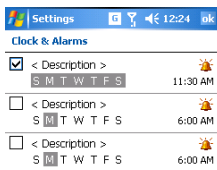

Setting Alarms

To choose how to be notified about events or actions

1. Tap Start > Settings > Personal tab > Sounds & Notifications.
2. On the Sounds tab, choose how you want to be notified by selecting the appropriate check boxes.
3. On the Notifications tab, in Event, tap an event name and choose

how you want to be notified by selecting the appropriate check boxes. You can choose from several options, such as a special sound, a message, or a flashing light.

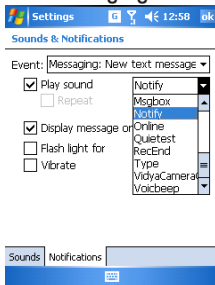

Changing Notifications

2.4 General Settings

To set the time and date

1. Tap Start > Settings > System tab > Clock & Alarms.
2. Select the correct time zone and change the date or time.

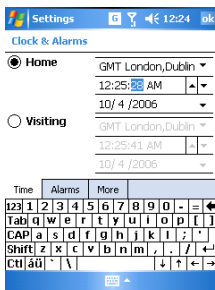

Setting the Time





During synchronization, the time on your device is updated with the time on your PC.

To set the time and date for a different location

If you visit or communicate with someone in a particular time zone often, you can select it as your visiting time zone.

1. Tap Start > Settings > System tab > Clock & Alarms.
2. Tap Visiting.
3. Select the correct time zone and change the time or date.



Updating the Visiting TimeZone

To change language and regional settings

The style in which numbers, currency, dates, and times are displayed is specified in regional settings.

1. Tap Start > Settings > System tab > Regional Settings.
2. On the Region tab, select your region and language.
3. The region you select determines which options will be available on the other tabs.
4. To customize settings further, tap the appropriate tabs and select the desired options.

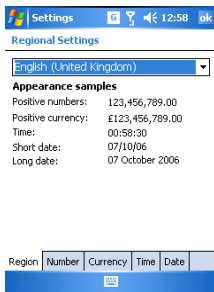

Regional Settings

To reassign programs or shortcuts to program buttons

1. Tap Start > Settings > Personal tab > Buttons.
2. A list of buttons and their current assignments is displayed on the Program Buttons tab.
3. Tap the button you want to reassign. To help you identify the buttons, there are numbers and icons representing the original function of the button.
4. In the Assign a program box, tap the program or shortcut you want to assign.
5. Tap OK.

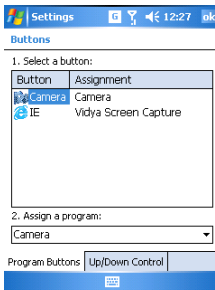

Assigning Buttons



To increase or decrease the size of text on the screen

1. Tap Start > Settings > System tab > Screen > Text Size tab.
2. Move the slider to increase or decrease the text size.

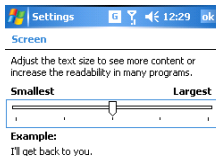

Screen Text Size

To adjust the speed for scrolling

Pressing and holding NAVIGATION up or down (Up/Down control) scrolls through the items in a list.

1. Tap Start > Settings > Personal tab > Buttons > Up/Down Control tab.
2. Do one of the following:
 - Under Delay before first repeat, move the slider to shorten or lengthen the time that elapses before scrolling begins.
 - To change the time it takes to scroll from one item to the next, under Repeat rate, move the slider to adjust the speed.

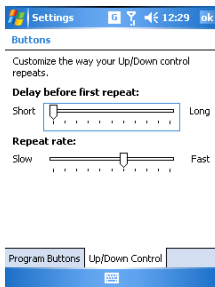

Scrolling speed

To change the device name

1. Tap Start > Settings > System tab > About.
2. Tap the Device ID tab.
3. Enter a name.

The device name is used to identify the device in the following situations:

- Synchronizing with a PC
- Connecting to a network
- Restoring information from a backup

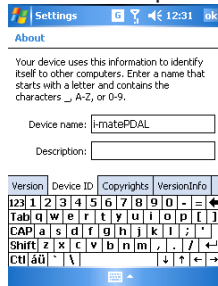

Updating Device Name





The device name must begin with a letter, consist of letters from A to Z, numbers from 0 to 9, and cannot contain spaces. Use the underscore character to separate words. If you synchronize multiple devices with the same PC, each device must have a unique name.

To make the battery last longer

1. Tap Start > Settings > System tab > Power. On the Advanced tab, you can specify when your device turns off to conserve battery power. For optimum conservation, specify 3 minutes or less.
2. Use the AC adapter to plug your device into external power whenever possible, especially when using a miniSD card or when using a modem or other peripherals.
3. Adjust the backlight settings.

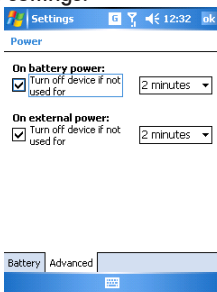

Automatic turn-off

To adjust the brightness of the backlight

1. Tap Start > Settings > System tab > Backlight > Brightness tab.
2. Move the sliders right to increase the brightness, or left to decrease the brightness.

To set the backlight to dim after a time delay

1. Tap Start > Settings > System tab > Backlight.
2. Tap the Battery power tab, or the External power tab.

3. Select the Turn off backlight if device is not used for check box, and specify the time delay.

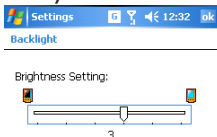

Brightness Menu

To close a program

In most cases, programs automatically close to free needed memory, however, you can close programs manually, if you prefer.

1. Tap Start > Settings > System, and tap > Memory > Running Programs .
2. In the Running Programs list, tap the program you want to close, and tap Stop.



In most programs, you can also use the shortcut “CTRL+Q” on the on-screen keyboard to close the program.





Stopping running programs

To change the orientation of the screen

You can use your Pocket PC in both landscape and portrait modes, depending on how you wish to use the device.

1. Tap Start > Settings > System tab > Screen > General tab.
2. Choose whether you wish to use the device in Portrait Mode, Landscape (for right handed usage) or Landscape (for left handed usage). Press OK to make the change occur.

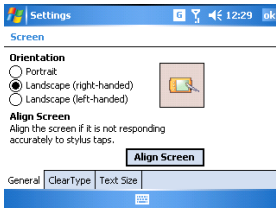
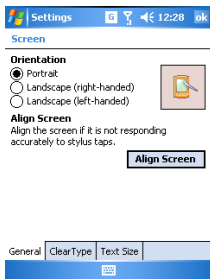

2.5 Security

To protect your phone with a PIN

1. From the Phone keypad, tap Menu > Options > Phone tab.
2. Tap Require PIN when phone is used.
3. To change the PIN at any time, tap Change PIN.



Emergency calls can be placed at any time, without requiring a PIN.

To protect your device with a password

You can help keep your data more secure by requiring a password every time the device is turned on.

1. Tap Start > Settings > Personal tab > Lock.
2. Select the Prompt if device unused for check box, and in the box to the right, select how long your device must be turned off before a password is required. In the Password type box, select the type of password you would like to use. Enter the password and, if necessary, confirm the password. If your device is configured to connect to a network, use a strong password to help protect network security.
3. On the Hint tab, enter a phrase that will help you remember your password, but doesn't allow others to guess your password. The hint will be displayed after the wrong password is entered four times.
4. Tap OK. The next time the device is turned on, you will be prompted to enter your password.



Each time a wrong password is entered, the time the device takes to respond will get longer and longer until the device appears to be not responding.

If you forget your password, you must follow the instructions in your owner's manual to clear memory before you can access your device.



To change your password

1. Tap Start > Settings > Personal tab > Lock. You will be prompted to enter your current password.
2. In the Password box, enter your new password.
3. On the Hint tab, enter a phrase that will help you remember your new password, but doesn't allow others to guess your password. The hint will be displayed after the wrong password is entered four times.
4. Tap OK.

Chapter 3.

Using your phone

- 3.1 Making a call
- 3.2 Receiving a call
- 3.3 In-Call Options
- 3.4 Special Dialing Requirements
- 3.5 Additional Settings

3.1 Making a Call

Like a standard mobile phone, you can use your Pocket PC Phone to make, receive and keep track of calls. You can also take notes while talking, dial directly from Contacts, and easily copy SIM contacts to Contacts on the device.

In order to make calls, you will need to insert your SIM card into the device as described in Chapter 8. Most SIM cards are preset with a PIN (personal identification number), which is provided by your wireless service provider. If this option is enabled in your SIM, you will be prompted to enter the PIN when the unit is switched on.



If your PIN is entered incorrectly three times, the SIM card will be blocked. If this happens, you can unblock it with the PUK (PIN Unblocking Key) obtained from your wireless service provider.

You can make a call from Phone, Contacts, Speed Dial, Call History, and SIM Manager.

Make a call from Phone

On the Phone screen, tap the desired phone number, and tap the Talk button. To open the Phone screen, do one of the following:

- Use the stylus and tap Start > Phone.
- Press the TALK  button .
- From the Today Screen, directly dial the phone number by pressing numeric keys on the hardware keyboard

Make a call from the Contacts application

- Tap Start > Contacts.
- Tap the desired contact, and press TALK twice (once to send the number to the Phone keypad, and once to dial the number).

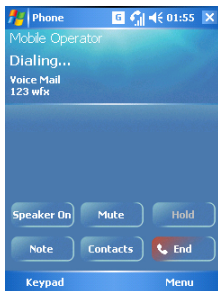

- You can also tap the desired contact in the contacts list, and tap the phone number that you want to call. Or, tap and hold the desired contact, and on the shortcut menu, tap Call Work, Call Home, or Call Mobile.

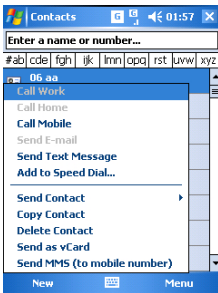

By default, the mobile telephone number (w) of a contact is dialed when you make a call from Contacts. However, you can specify that a different phone number is used instead.

1. Tap Start > Contacts.
2. Press NAVIGATION up or down to select the contact.
3. Press NAVIGATION left or right. The letters representing the number will change as you scroll through them.

Make a call from Call History

1. On the Phone screen, tap the Call History button.
2. Tap Menu > Filter and tap a category.
3. Scroll to the desired contact or phone number, and tap Call.



Make a call from Speed Dial

Use Speed Dial to call frequently-used numbers with a single tap. For example, if you assign a contact to the location 2 in Speed Dial, you can simply tap and hold on the Phone screen to dial the contact's number. Before you can create a Speed Dial entry, the number must already exist in Contacts. To create a Speed Dial entry:

1. On the Phone screen, tap Menu > Speed Dial.
2. Tap Menu > New.
3. Tap a contact. Tap the phone number for which you want to create a Speed Dial.
4. In the Location box, select an available location for the new Speed Dial.





To create a Speed Dial entry from Contacts, tap and hold the contact name, tap Add to Speed Dial, and select an available location for the new Speed Dial. To delete a Speed Dial entry, in the Speed Dial list, tap and hold the desired entry, and tap Delete.

To make a call from SIM Manager

SIM Manager allows you to view the contents of your SIM card, transfer SIM phonebook entries to Contacts on your device, and make a call from your SIM card.

1. Tap Start > Programs > SIM Manager. Wait for your SIM card contents to load.
2. Tap a name or phone number of the person you want to call, and Select Menu> Dial Number.

Making an emergency call

To make an emergency call just enter the emergency phone number for your location and press TALK.



You can make calls to emergency services under any circumstances, even if you have enabled the SIM PIN or locked the device. The ability to make emergency calls is dependent on network availability

3.2 Receiving a Call

When you receive a phone call, a message will appear, giving you the option to either answer or ignore the incoming call.

1. To answer the call, tap Answer, or press TALK on the device.
2. To reject the call, tap Ignore, or press END on the device.

To end a call

Once an incoming or outgoing call is in progress, you can tap End or press END on the device to hang up.

3.3 In Call Options

To put a call on hold

If this option is enabled, your device notifies you when you have another incoming call, and gives you the choice of rejecting or accepting the call. If you are already on a call and accept the new call, you can choose to switch between the two callers, or set up a conference call between all three parties.

1. Tap Answer to take the second call, and put the first one on hold.
2. To end the second call and return to the first call, tap End or press END on your device.
3. To switch between calls, Tap Swap.

To set up a conference call

1. Either put a call on hold, and dial a second number; or, accept a second incoming call when you already have one in progress.
2. Tap Conference.



NOTE Not all service providers support conference calling
Contact your service provider for details.

To turn on and off the Speakerphone

The built-in Speakerphone on your device allows you to talk hands-free or lets other people listen to the conversation. The speakerphone icon  appears in the title bar.

To turn off the speakerphone, tap Speaker Off, or press and hold TALK again until the speakerphone turns off.

To mute a call

You can turn off the microphone during a call, so that you can hear the caller but the caller cannot hear you. During a call, tap Mute .

- When the microphone is turned off, the mute icon () appears on the screen.
- Tap Unmute to turn on the microphone again.

3.4 Special Dialing Requirements

Insert a pause in a dialing sequence

Calls to certain networks may require a pause in between the dialed digits. To do this,

1. Tap Start > Contacts
2. Click the contact in whose phone you want to insert a pause.
3. Select the phone number and add a 'p' character where you want to insert a 3 second pause.
4. Select the phone number and add a 'w' character where you want to insert a manual pause.



To resume dialing after reaching a manual pause, press TALK.

Insert an International Country Code

To make an international code, you must insert a country code at the beginning of the dialing sequence for the phone number.

- Tap and Hold 0 on the Phone keypad until a (+) sign appears and then insert the rest of the number. You can also (+) directly from the qwerty keyboard.

3.5 Additional Settings

Phone services

Phone Services, such as Call Waiting, enable you to choose how to handle all incoming calls on your device.

To choose the services

Tap Start > Settings > Phone > Services tab.

Tap the service you want to use and tap Get Settings.

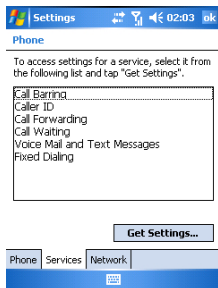

Networks

You can view available wireless networks, determine the order in which your device accesses another network if the current one is unavailable, and specify whether you want to change networks manually or automatically. For more information about network settings, see [Help on your device](#).

To change phone network settings

1. Tap **Start** > **Settings** > **Phone** > **Network** tab.
2. By default, your device displays the current network as offered by your service provider. You can customize to set your preferred network.

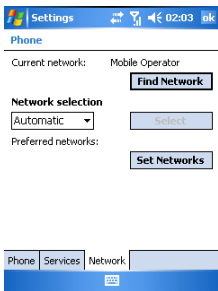

To set preferred networks

1. Tap Start > Settings > Phone > Network tab. By default, Network selection field is set to Automatic. However, you can set it to Manual to choose your own network at any point of time.
2. Tap Set Networks.
3. Select the networks on the Phone: Preferred networks screen and sort them according to your preference.
4. Tap OK.

To change the keypad tone

You can change the tone you hear when entering a phone number on the keypad. If set to Long tones, the tone is heard continuously for as long as the number on the keypad is pressed. Use this setting if you are having trouble accomplishing tasks that rely on tones from your phone such as accessing messages from an answering machine. If set to Short tones, the tone is heard only for one or two seconds. If set to Off, no tone will be heard.

1. From the Phone keypad, tap Menu > Options > Phone tab.
2. In the Keypad list, tap the option you want.

Chapter 4.

Getting connected

Topics

- 4.2 Manual setup of your data connections
- 4.3 Bluetooth
- 4.4 Beams
- 4.5 Connecting to a Wireless LAN

4.1 Automatic setup of your GSM/GPRS data connections

Your device is equipped with powerful networking functions that enable you to connect to the Internet through a General Packet Radio Service (GPRS) network. GPRS is a service that allows information to be sent and received across a mobile telephone network.

Your device is able to configure itself for data services for many of the major GSM/GPRS operators across the world. Simply insert your SIM card and switch on your device. When the device powers on it will configure itself for Web, MMS and WAP services. If the settings are not known for your operator, the device will notify you and you will need to enter these manually.



The use of Web, WAP and Multimedia Messaging Services is subject to your Mobile Service Provider. You must ensure that your subscription has Web, WAP and MMS before using those services.

4.2 Manual setup of your data connections

You can set up connections to the Internet or to a corporate network to browse the Internet, and exchange e-mail or instant messages.

Your device has two groups of connection settings: My ISP (Internet Service Provider) and My Work Network. The My ISP settings are used to connect to the Internet, while My Work Network settings can be used to connect to any private, corporate network.

To connect to the Internet via ISP

1. Obtain the following information from your ISP:
 - Access Point Name or Server phone number
 - User name (if required)
 - Password (if required)
 - Domain (If provided by an ISP or a network administrator)
 - Proxy settings (if required).

2. Tap Start > Settings > Connections tab > Connections.
3. Tap Add a new modem connection.
4. Enter a name for the connection.
5. Select a modem from the list. For example, if you want to use the mobile phone network, select Cellular Line.
6. Tap Next.
7. Complete the connection wizard by entering the required information and tap Finish.



To connect to a private network

1. Obtain the following information from your network administrator:
 - Access Point Name or Server phone number
 - User name (if required)
 - Password (if required)
 - Domain (If provided by an ISP or a network administrator)
 - Proxy settings (if required).
2. Tap Start > Settings > Connections tab > Connections.
3. In My Work Network, follow the instructions for each type of connection.
4. Once finished, tap on “Edit my proxy server”, and enter the Proxy Information, including any WAP Proxy required by the operator if setting up a connection to their WAP site.
5. Complete the connection wizard, then tap Finish.



To start browsing the Internet or private network, tap Start > Internet Explorer.

Connect to a VPN from the internet

Please ensure that you have setup a successful GPRS/WiFi connection. The VPN connection uses the existing Internet connections to connect to your Work Network. Please refer to the next section “Connect to Intranet URLs” for further information on this subject.

1. If the Work Connection is not being used for any other connection, tap on “Add a new VPN sever” connection and skip to step 4.
2. Start > Settings > Connections > Connections > Advanced > Select Networks.
3. Create a new connection to a private network pressing “New...” in the lower part of the screen. This new network connection must be selected in this menu when required to connect to VPN. Assign a name of your choice and tap on the VPN tab. Then press New.
4. Complete the VPN setup wizard using the settings provided by your network administrator, which should include: Host Name/IP, VPN Type, User Name, Password and Domain.

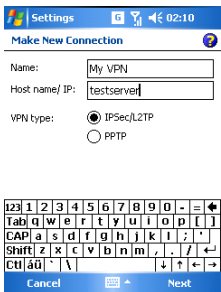

5. If you selected IPSecin VPN type, press next to select the type of authentication required. If Pre-Shared key is selected, enter the key.
6. Check the advanced settings and complete the settings according to the instructions from your network administrator.

Connect to Intranet URLs

A work URL exception tells Internet Explorer Mobile and/or ActiveSync to look on the Work Network to find that URL instead of searching the Internet. This has to be setup also if you wish to browse websites in your intranet through your VPN connection:

1. On the home screen press Start > Settings > Connections > Advanced > Add new URL.
2. In Work URL, enter the URL and Click Done. Separate multiple URLs with a semicolon.



You should not create URL exceptions for URLs on the Internet. An Intranet URL can be either an IP address or FQDN (Fully Qualified Domain Name).

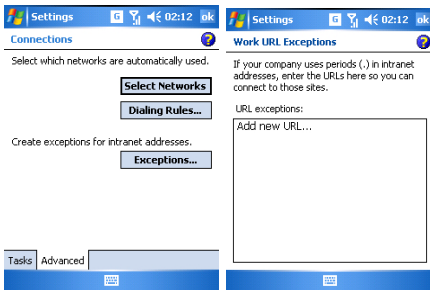

4.3 Bluetooth

Bluetooth is a short-range wireless communications technology. Devices with Bluetooth capabilities can exchange information over a distance of about 10 metres without requiring a physical connection. You can even beam information to a device in a different room, as long as it is within the Bluetooth signal coverage range.

The software included with your device allows you to use Bluetooth in the following ways:

1. Beam information, such as files, appointments, tasks, and contact cards, between devices that have Bluetooth capabilities.
2. Create a dial-up modem connection between your device and a Bluetooth-enabled phone, then transfer data using the Bluetooth phone as a modem.
3. Use a Bluetooth headset.

To turn on or off Bluetooth on your device

1. On your device, tap Start > Settings > Connections tab > Bluetooth.
2. Select the Turn on Bluetooth.
3. Select the “make this device discoverable to other devices” check box if you want your device to be visible to other Bluetooth users in a range of approximately 10 meters.
4. Tap OK.
- 5.



Bluetooth can also be enabled from the Bluetooth icon in the Wireless Manager application in your Today Screen.

To create a Bluetooth partnership

A Bluetooth partnership is a relationship that you create between your device and another Bluetooth-enabled device in order to exchange information in a secure manner. Creating a partnership between two devices involves entering the same personal identification number (PIN) or Passkey on both devices. Creating a partnership between two devices is a one-time process. Once a partnership is created, the devices can recognize the partnership and exchange information without entering a PIN again. Make sure the two devices are within a range of 10 meters from one another, and Bluetooth is turned on and in discoverable mode.

1. On your device, tap Start > Settings > Connections tab > Bluetooth.



Bluetooth

- Turn on Bluetooth
- Make this device visible to other devices

To connect to a device, click on the Devices tab below.



2. On the Devices tab, tap **Add New Device**. Your device searches for other Bluetooth devices and displays them in the box.



Bluetooth

Tap Add new device to search for other Bluetooth devices. Tap on a device to modify its settings.

Add new device...



3. Tap the desired device name in the box.



Select a Bluetooth Device

Select a device to connect with and tap Next.

Hands Free device

Refresh



4. Tap Next.
5. Enter a passkey to establish a secure connection. The passkey must be between 1 and 16 characters.



6. Tap Next.
7. Enter the same passkey that is entered on the other device. You can, however, edit and enter a new name for the other device.



8. Tap Finish after checking the services offered by the other Bluetooth device.

To accept a Bluetooth partnership

1. Ensure that Bluetooth is turned on and in discoverable mode.
2. Tap Yes when prompted to establish a partnership with the other device.
3. Enter a passkey (the same passkey that is entered on the device requesting the partnership) to establish a secure connection. The passkey must be between 1 and 16 characters.
4. Tap Next.
5. Tap Finish. You can now exchange information with the other device.

To rename a Bluetooth partnership

1. Tap Start > Settings > Connections tab > Bluetooth.
2. Tap and hold the partnership on the Devices tab.
3. On the shortcut menu, tap Edit.
4. Enter a new name for the partnership.
5. Tap Save.

To delete a Bluetooth partnership

1. Tap Start > Settings > Connections tab > Bluetooth.
2. Tap and hold the partnership on the Devices tab.
3. Tap Delete from the shortcut menu.





On <http://www.clubimate.com> you can find step-by-step guidelines for configuring your device for use as a Bluetooth Wireless Modem and for connecting to a PC using ActiveSync over Bluetooth. Those guidelines are also available in the CD that came with your device.

4.4 Beams

The term Beam is used to describe the short range transferring of information between two units. Beaming only refers to passing information Bluetooth. An example of beaming could be you wishing to send the details of a contact to another Windows Mobile device.



By default, the option to receive incoming beams is disabled for security and battery saving reasons. Make sure that “Receive All Incoming beams” is enabled in Start > Settings > Connections > Beam.

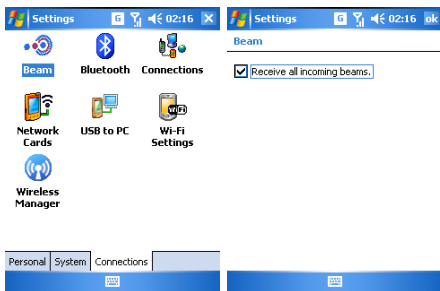

To Beam an item

In the Calendar, Contacts, Notes, Tasks, and Pictures programs, you can beam files and information to other devices using Bluetooth

1. From the program, select the item you want to beam, such as an appointment in Calendar, a task in Tasks, a contact card in Contacts,

- or a picture in Pictures. In Calendar, first open the appointment in Agenda view.
2. Click Menu > Beam [type of item]. In the contacts application, you should go to Menu > Send Contact > Beam

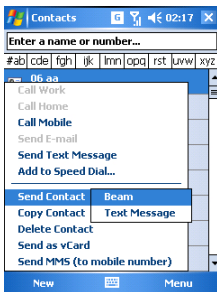

3. Select the device to which you want to send the item.
4. Tap on "Tap to Send".

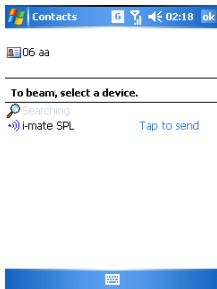

4.5 Connecting to a Wireless LAN

Connect to a Wi-Fi network

1. Tap on the Wireless Manager in the Today Screen.
2. Tap the Wi-Fi button to turn on/off the wireless function.



3. When the Wi-Fi function is turned on the device will start scanning for networks and will prompt the user to select one of the users.

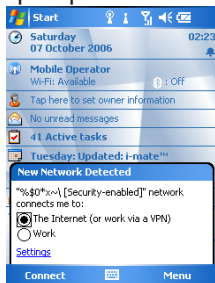

Select whether this network is used to connect to The Internet or for a Work Connection and enter the password for this access point if requested.

- On the Wireless Manager screen, tap Settings > Wi-Fi Settings to configure the required settings. When the configuration is completed, you can connect to a Wi-Fi network using your device.

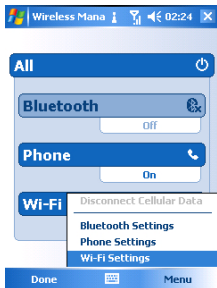

To save battery power while connected to a Wi-Fi network

- On the Settings tab of the Wireless LAN Settings screen, move the Power

Save Mode slider to a position that optimizes performance with the least power consumption. For example, move the slider to left (Best Performance) to achieve the optimal WLAN performance; move to right (Best Battery) to maximize battery life.

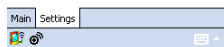
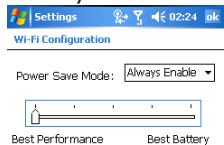

To check the Wireless LAN status

You can check the current wireless connection status from the following the screens of your device:

- **Wireless LAN Main screen.** Start > Settings > Connections > WLAN settings provides information about the connection status and signal quality for the current connection.

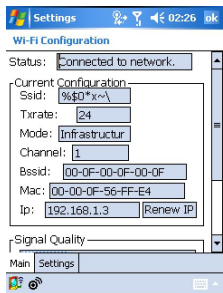

- To manually Configure your connection, tap Start > Settings > Connections tab > Network Cards. This screen displays the wireless networks currently available and allows you to change the connection settings and create new connections to other access points not broadcasting their SSIDs.

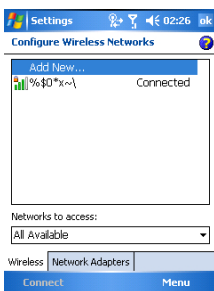
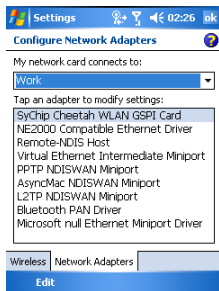

On <http://www.clubimate.com> you can find step-by-step guidelines for connecting your device to public and private WiFi access points. Those guidelines are also available in the CD that came with your device.

Chapter 5.

Messaging

5.1 Text Message

5.2 E-mail

5.3 MMS

5.4 Pocket MSN

This chapter describes how you can create or delete, send or receive, and organize or store your messages in the phone. The following types of Messages are all stored under the Messaging Application:

- Text messages (SMS – Short Message Service)
- Email messages
- Multimedia messages (MMS)

Real-time messaging is also possible on your device by signing into the MSN Messenger application, as explained in this chapter.

5.1 Text message

Text Messaging is a popular way of sending short messages to other mobile phone users, and in some countries to land lines as well. Each text message is a maximum of 160 characters long. In some countries the maximum size is 70 characters if accented or other special characters are used. Several text messages can be joined together to make one message, and your device will do this automatically.

Create a text message

1. On the Today screen, tap Start > Messaging
2. From the drop down list at the top of the screen choose the 'Inbox' icon in the 'Text Messages' account

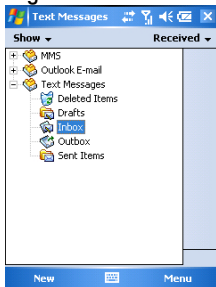

- From the bottom of the screen, press New.

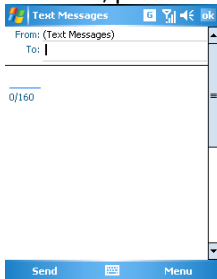

- In the To: field, enter the mobile phone number of recipients. Insert a semicolon (;) between multiple recipients. You may also choose a contact by pressing Menu > Add Recipient
- Tap Send. The Text messages are sent immediately.



In the To: field, you can enter phone numbers from your contact cards quickly. Press ENTER when the cursor is in this field. A new screen displays the contact list for your selection. Press ENTER again for the selection and the phone returns to the SMS text message screen. Repeat this for as many contacts you wish to send the SMS message to.

To cancel a message, press Menu > Cancel Message.

If you require Delivery notification, in the message creation screen above, press Menu > Message Options... and tick the box for 'Request message delivery notification'.

Insert predefined text into message

To save time when entering text, you can insert predefined text into messages.

- Tap Menu > My Text.
- Select the text you want to insert by tapping the phrase you wish to insert.

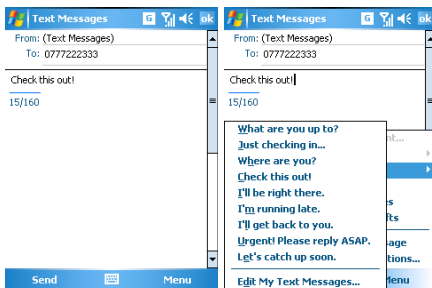

Reply to a message

1. From the Text Message inbox or from an open message, tap Reply or Menu > Reply All.

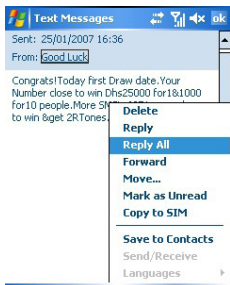

2. Enter a message in the message area.
3. Press Send.



Saving SMS on SIM: Start > Messaging > Select a message > Menu > Save to SIM

Forward a message

1. From an open message, tap Menu > Forward.

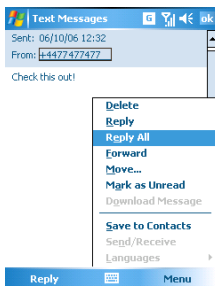

2. Enter a message in the message area.
3. Choose a recipient to send the message to; either type in the name or tap Menu > Add recipient
4. Tap Send.

Delete a message

1. On the Home screen, tap Start > Messaging and select an account.
2. Select the message to delete.

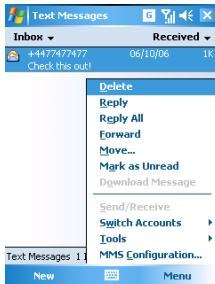

3. Tap Menu > Delete.

5.2 E-mail

Before you can send or receive emails, you will need to setup an email account. There are different types of email accounts supported by the phone. This is described in the next few pages.

- Internet email account (POP3/IMAP4)
- Exchange Server (Outlook)

Set up an Internet email account automatically

1. On the Home screen, tap Start > Messaging, and select an account.
2. Tap Menu > Tools > New Account.
3. Select "Other (POP3/IMAP)" as your email provider

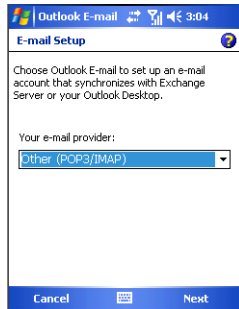

4. In E-mail address, enter the e-mail address for this account.
5. Enter your name, user name and password
6. Enter your account information
7. Input your server information that is provided from your email provider



If the account is set up successfully, you will be prompted to send and receive e-mail. If not, you must tap Next and set up the account manually which is described in the following pages.

You will need to enter your user name and password for your email account

Set up an Internet email account manually

Before you set up your Internet e-mail account, ensure that you have the necessary information as listed in the table below. Usually, manual setup is only needed if automatic setup as described in the previous section has failed.

Setting	Description
User name	Usually the first part of your e-mail address, which appears before the at sign (@).
Password	Choose a strong password. You will have the option to save your password, so that you do not need to enter it each time you connect to your e-mail server.
Domain	The domain name. This may or may not be required by your Internet Service Provider.
Server type	The type of e-mail server that hosts your mailbox (POP3 or IMAP4).
Account name	A name for this account. You must use a different name for each account that you set up.
Network	The type of network your e-mail server connects to.
Incoming mail server	The name of your e-mail server (POP3 or IMAP4).
Require SSL connection	Select this to ensure you always receive e-mail for this account using an SSL connection. This enables you to receive information more securely. Please note that if you select this and your ISP does not support an SSL connection, you will not be able to connect to receive e-mail.
Outgoing mail server	The name of your outgoing e-mail server (SMTP).
Outgoing server requires authentication	Your outgoing e-mail server (SMTP) may require authentication. Note: Your user name and password from above will be used.

Outgoing server settings	Your outgoing e-mail server may require different authentication settings than your incoming e-mail server.
Use different user name for outgoing server	A check box that lets you enter separate settings for your outgoing e-mail server.
User name	Your user name for the outgoing e-mail server.
Password	Your password for the outgoing e-mail server.
Domain	The domain name of the outgoing e-mail server.
Require SSL connection (Outgoing mail server only)	A connection that enables you to send information more securely. Note that if you select this and your ISP does not support an SSL connection, you will not be able to send e-mail.

Now you're ready to set up your account.

1. On the Home screen, tap Start > Messaging, and select an account.
2. Tap Menu > Options > New Account.
3. In Your name, enter your display name for e-mail messages.
4. In E-mail address, enter the e-mail address for this account/
Password
5. Tap Next.
6. Enter the information above as appropriate until setup is complete, and tap Finish.



If you save your password and then lose your phone, someone finding your phone might be able to gain access to your e-mail.

Set up an Outlook e-mail account

An Outlook e-mail account is created and managed by Microsoft's Exchange Server. You will need to have this account setup first before carrying on with the other steps described in this section.

For sending and receiving messages with your Exchange Server, tap Start > ActiveSync

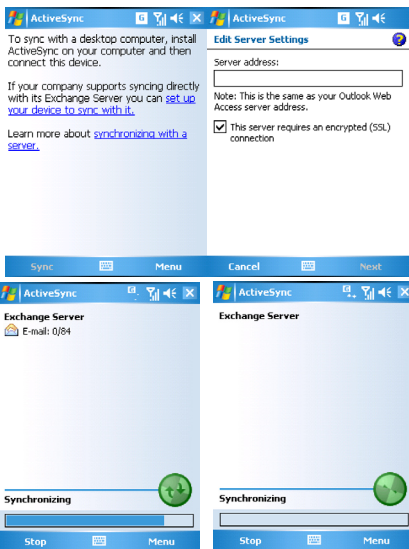

You will get the following prompt on your phone if your Exchange Server supports MSFP – Microsoft “Messaging and Security Features Pack”, and your email administration team are enforcing security policies to your device. These security policies may be to lock the device from unauthorized access after the device has been left unused for a period of time, or for the ability to wipe the device ‘over the air’. Your administrator will be able to tell you which policies are being applied to your device.

Exchange Server 2003 with SP2 has the option to utilize the MSFP. One of the benefits is the ability for the Server to push new e-mails as they arrive to the Outlook client in the phone.

When ActiveSync has synchronized successfully, tap Start > Messaging and Choose the Outlook Email tab. You should see e-mail folders similar to the Outlook client in a PC.

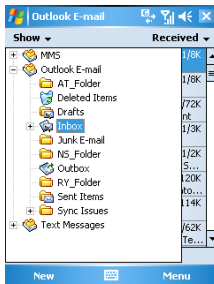

Please refer to section 6 for further information on how to synchronize with an Exchange Server. Also, on <http://www.clubimate.com> you can find step-by-step guidelines on how to set up email on your i-mate device. Those guidelines are also available in the companion CD that came with your device.

View the Inbox message list

On the Home screen, tap Start > Messaging, and select an account. The Inbox message list displays your received messages.



To quickly view new messages when they arrive, tap on the Notification on the Home screen.

Create an e-mail message

1. On the Home screen, tap Start > Messaging.
2. Select an e-mail account from the drop-down list.
3. Tap New.
4. In To, Cc, and/or Bcc, enter recipient e-mail addresses. Insert a semicolon (;) between multiple addresses.
5. In Subject, enter a subject for the mail.
6. Enter a message.
7. Tap Send. E-mail messages are stored in Outbox and are sent to recipients the next time you synchronize or connect to your e-mail server and send and receive mail.



You can quickly enter e-mail addresses from your contact cards. In the To field, press ENTER and select a recipient from the list. Then, select the recipient's e-mail address. The semicolon separator is automatically inserted if you enter multiple recipients.

To set the priority of the mail (i.e. to appear as a Low, Normal or High priority in the recipient's inbox), tap Menu > Message Options.

To cancel a message, tap Menu > Cancel Message.

Insert predefined text into message

As described in Section 5.1 Text Message, please refer to the section for details for how to use this facility. You can use it when creating a new message or replying to an e-mail. When the message screen appears, tap Menu > My Text

Create and add a signature to message

For each account in Messaging, you can specify a signature to be automatically inserted into messages that you send.

1. On the Home screen, tap Start > Messaging and select an account.
2. Tap Menu > Tools > Options... Then tap the Signatures button
3. Scroll to the account for which you are creating the signature.
4. Select Use signature with this account.

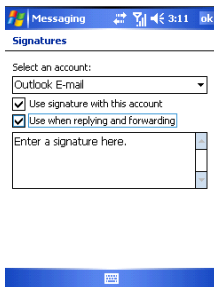

5. To insert a signature in every message you send, select Include when replying and forwarding. Otherwise, a signature is inserted only in new messages.
6. Tap the Signature box, enter your signature, and tap Done.

Reply to a message

1. From an open message, tap either the soft-key Reply or tap Menu > Reply All.
2. Enter a message in the message area.
3. Tap Send.

If you are replying to an e-mail in the Outlook E-mail account, you will send less data if you do not edit the original message. This may reduce data transfer costs based on your rate plan.

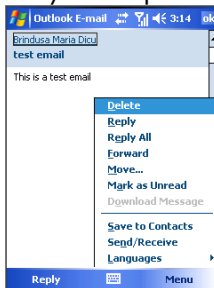

Send and receive internet e-mail messages

1. On the Home screen, tap Start > Messaging.
2. Select the Internet e-mail account for which you want to send and receive messages.
3. Tap Menu > Send/Receive. The phone connects to your Internet e-mail server and sends and receives your messages.



To stop this process, tap Menu > Stop Send/Receive.

Download a complete e-mail message

1. On the Home screen, tap Start > Messaging and select an account.
2. Select the message to download.
3. Tap Menu > Download Message. The complete message is retrieved the next time you synchronize or connect to your e-mail server to send and receive e-mail.



Alternatively, you can scroll down to the bottom of the message and tap "Get the rest of this message". The message will be downloaded the next time your phone connects to the Server to send/receive e-mail. The frequency of this is determined by the Schedule setup during your ActiveSync configuration described in Chapter-6.

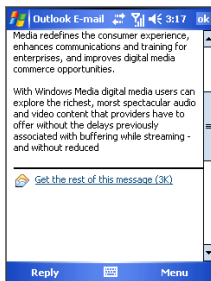

Download an attachment

In an open message with an attachment to download, tap on the attachment that you wish to download. The attachment is downloaded the next time you synchronize or connect to your e-mail server and send and receive e-mail.

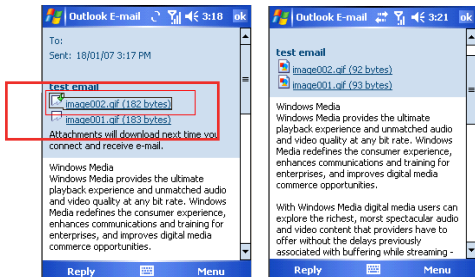

After you scroll down to the filename shown, tap again and the attachment file will be downloaded when your phone connects to your server to send/receive e-mails again.

View an attachment

- In an open message containing a downloaded attachment, tap the attachment.



You can view attachments only for file types that are supported by the device.

Add a picture to an e-mail message

1. In the message area of an e-mail message, click **Menu** > **Insert** > **Picture**.
2. Click the picture you want to add.

Digitally Sign a message

Digitally signing a message applies your certificate with the public key to the message. This proves to the recipient that the message is from you and not from an imposter, and that the message has not been altered.

1. In the message list, click Menu > Switch Accounts > Outlook E-mail.
2. Click New.
3. Click Menu > Message Options.

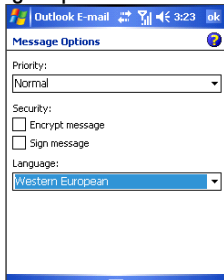

4. Select Sign message and click Done.



S/MIME encryption and digital signatures for Windows Mobile-based devices are available only with Exchange Server 2003 Service Pack 2 or a later version that supports S/MIME. If you are not using one of these products, or have not yet synchronized, these options are unavailable.

Change between e-mail folders and accounts

1. Tap Start > Messaging
2. Tap Menu > Go To > Folders
3. You can select the new folder you wish to view

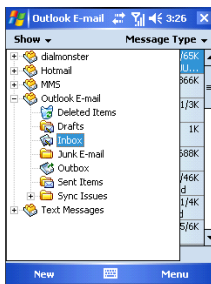

5.3 MMS

Creating and sharing MMS messages with your friends and family is easy with your device. You can even use the device camera to capture photos while composing a new MMS message, and send them along with your message.

Set up MMS

Before you can use MMS, you have to configure the required settings on your device. If your mobile operator settings are recognized by the device when it first boots-up, then the MMS settings should be set up automatically.

To access MMS

- Tap Start > Messaging > Menu > Go To > MMS



You can also send an MMS message directly from the Pictures & Videos or Camera programs. Do one of the following:

- Select a picture from My Pictures, and tap Menu > Send. In Select an account, tap MMS.
- Capture a photo or an MMS video clip using the camera, and tap Send. In Select an account, tap MMS.

To set up an MMS account Manually

- To set up your default MMS Messaging account tap Start > Messaging > Menu > Go To > MMS.
- Tap Menu> MMS Configuration and enter details of your mobile operator's MMSC.

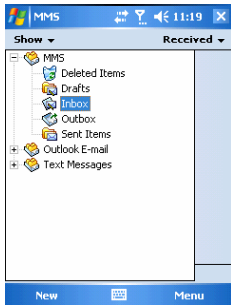





Manage MMS messages

After configuring the required settings, you can start to compose and manage your MMS messages.

To start composing an MMS message



You can compose MMS messages in a combination of various slides, where each slide can consist of a photo, audio or video clip, and/or text.

1. Tap Start > Messaging > Menu > Go To > MMS
2. Tap New
3. In To, enter the recipient's phone number or e-mail address directly, or tap To, Cc, or Bcc to choose a phone number or an e-mail address from Contacts.
4. Enter a subject for your message.

5. Tap the Insert icon () to select and send a photo or video clip. By default, it will open My Picture folder. To navigate to any other folder containing pictures or videos, tap the Down arrow corresponding to My Pictures folder.
6. Select a photo or video clip. When selected, you can:
 - Tap  to view it.
 - Tap  to insert the image into the MMS message you are composing.
 - Tap  to discard it.
 - Tap and hold the thumbnail to display a shortcut menu containing the options: File Info and Delete. Select File Info to display the file information of the photo or video clip; select Delete to remove the selected photo or video clip.
7. Enter text and insert audio clips by tapping the respective areas.
8. Tap Send to send the message.



The following icons act as shortcuts to some of the operations on the MMS Message screen:

- Tap  to preview your message
- Tap  to go to the previous slide
- Tap  to go to the next slide

To create an MMS message from a template

- Tap Edit > New from Template to compose a message using a predefined template.



To save a message as a template, open the message and tap Edit > Save as Template.

To add predefined text strings to an MMS message



You can instantly add text to any slide from a list of predefined words or phrases, called Canned Text.

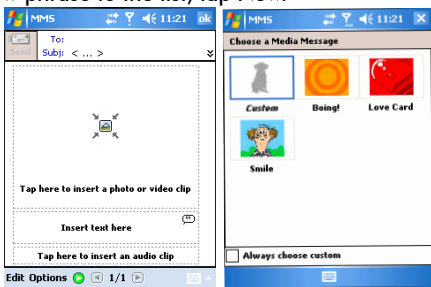



- Tap  to add a text string from the Canned Text list.
- To edit or delete a phrase on the Canned Text list, tap and hold a string, then tap Edit or Delete from the shortcut menu. To create and add a new phrase to the list, tap New.



To add an audio clip to an MMS message

You can add audio clips to your MMS message. However, you can add only one audio clip per slide.

1. Tap “Tap here to insert an audio clip”.
By default, it will open My Sounds folder. To navigate to any other folder containing pictures or videos, tap the Down arrow corresponding to My Sounds folder.
2. Select an audio file. When selected, you can:
 - Tap  to play the audio clip.
 - Tap  to pause.
 - Tap  to stop.



- Tap  to insert it into your MMS message.
- Tap  to discard it.
- To record a new audio clip and add it to your MMS message, tap . This activates the recording control mode for a new audio clip. Tap  to start recording, and  to stop recording. The new audio clip is automatically inserted into your MMS message.

To reply to an MMS message

- Tap Menu > Reply to reply to the sender of the message, or tap Menu > Reply All to reply to all persons listed in To, Cc, and Bcc of the message.

To view an MMS message

You can view MMS messages in several ways.

- Use the playback controls , , and .
- Tap Objects to see a list of files included in the message. To save a file, select it, and tap Tools > Save.
- View the slides manually by scrolling through the message using the NAVIGATION control.

To set advanced options for an MMS message

- Tap Options > Background to choose a background colour from the list.
- Tap Options > Text on Top to align the included text to appear at the top of the message.
- Tap Options > Text Below to align the included text to appear at the bottom of the message.
- Tap Options > Message Options to configure and manage the sending time, validity, priority, class, and other settings for a message.

Change MMS settings

You can set options to keep track of your messages, retrieve messages immediately, accept or reject messages, and request a delivery or read receipt. You can also specify a resolution for images you send, message delivery attempts, and set up a server to access messages.

To configure MMS settings

1. Tap Start > Messaging.
2. Tap Menu > MMS Configuration.
3. Select any of the following:
 - Retrieve messages immediately. Select this check box to download new messages automatically without being notified. (Typically, when you are connected to a network, you receive a notification whenever you receive a new message.) You can also choose to download messages when you are on your home network only.
 - Save sent messages. Select this check box to save a copy of messages that you send.
 - Reject all messages. Select this check box so all incoming MMS messages are not downloaded.
 - Allow delivery report and Allow read report. Select these check boxes to send and receive delivery and read reports.
 - Use signature with this account. When you select this check box, you can add your personal signature in the MMS messages. Edit your signature in the following Signature field.
 - Attempts before giving up. Select a value from this list to limit the number of times the program attempts to send your message.
 - Photo resolution. Select a value from this list to choose the resolution for images that you send. Decreasing the original resolution helps speed up the sending and receiving of messages.
 - Servers. On this tab, you can create a new server or select an existing one from the list to store and manage your messages. You can also set a server as default by tapping Set As Default.

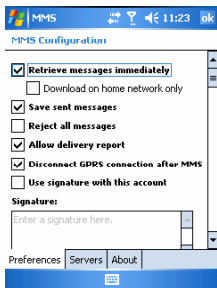

5.4 Pocket MSN

About Pocket MSN

Pocket MSN on your mobile device provides real-time access to your MSN Hotmail inbox, your MSN Messenger contacts list, and options for customizing your Pocket MSN experience.

MSN Messenger is an instant messaging service hosted by MSN through the Internet. At the time of writing this User Guide, this service is free of charge.

With Pocket MSN you get:

- MSN Hotmail. Read, write, and send e-mail, or manage your Hotmail folders.
- MSN Messenger. See who's online. Send and receive instant messages. Subscribe to status updates for selected contacts so you're notified when they're online.
- Options and settings you can use to create a custom Pocket MSN experience.
- To use it, tap Start > Programs > Pocket MSN



- You need to have either a Microsoft .NET Passport (from www.passport.com) or a Hotmail account (www.hotmail.com) to use MSN Messenger.
- Your phone first needs to be connected to the Internet.

About MSN Hotmail

With MSN Hotmail on your Pocket PC, you have access to your Hotmail inbox even when you're mobile. Read, send, and reply to e-mail, and manage your folders. Mark e-mail attachments for downloading so that you can view them.

Pocket MSN Messenger overview

With MSN Messenger you can send instant messages to your contacts mobile devices or computers. For instructions, select a task below.

Getting started with MSN Messenger

To use MSN Messenger, you need Microsoft Passport Network credentials. After obtaining credentials, complete the following tasks:

1. Set up a connection with your phone, refer to Chapter-4 Getting connected, that enables you to connect to the Internet.
2. Set up an MSN Messenger account. For more information, see Set Up an Account.

3. Sign in to MSN Messenger. For more information, see Sign In and Out.

To obtain a Passport, go to <http://www.passport.com>.

To create a Hotmail account, go to <http://www.hotmail.com>.

Sign in to Pocket MSN or Hotmail

The sign-in process helps to maintain secure access to your MSN Hotmail and MSN Messenger accounts. Sign-in lasts for 24 hours, regardless of power or connection loss. Just being signed in to Pocket MSN does not incur charges, but if you are also signed in to Messenger, or if you are sending and receiving e-mail you can incur charges.

1. On the Pocket MSN home screen, click Start > Pocket MSN.
2. Click Messenger or MSN Hotmail, and then enter the e-mail address and password you use to sign in to MSN Mobile. Click Save password to have Pocket MSN automatically sign you in.
3. Click Sign in.



Tap here to sign in



msn Messenger

Sign In



Menu



Caution This could be a security risk if your mobile device is lost or stolen, others may gain access to MSN Messenger and Hotmail. If you mobile device is lost or stolen, go to a computer and change your



Microsoft Passport credentials by logging into www.passport.com. If you have signed into MSN Messenger, you can access to your emails in your Hotmail account already without having to sign into Hotmail also.

View your Hotmail Inbox

1. In your Hotmail inbox, tap Start > Programs > Pocket MSN > MSN Hotmail.
2. To synchronize your Hotmail inbox so you see your latest e-mail messages, tap Menu > Send/Receive mail.

Write and send E-mail

1. Tap New at the bottom of the Hotmail inbox screen.
 2. In the To: field, enter an e-mail address.
 3. In Subject, enter the subject of the e-mail.
 4. Enter a message in the body of the e-mail, and then tap Send.
- To write or reply to e-mail while offline, follow the steps above. Then, when you have an open data connection, tap Menu > Send/Receive mail.

Reply to an E-mail Message

1. Select a message in your Hotmail inbox.
 2. Tap Reply or if you wish to include replying to recipients in the CC field also, tap Menu > Reply All
 3. Enter the text of your reply, and then tap Send.
- To write or reply to e-mail while offline, follow the steps above. Then, when you have an open data connection, tap Menu > Send/receive mail.

Keep your Hotmail Inbox always up-to-date

You can set your Hotmail inbox to automatically update with new e-mail whenever you have an open data connection.

1. In Pocket MSN tap Menu > Options > Hotmail.

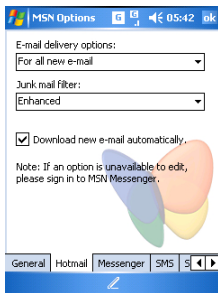

2. Tick **Download new e-mail automatically**, then tap **Done**.

Delete an E-Mail Message

1. Select a message in your **Hotmail** inbox.
2. Tap **Menu > Delete**. The message is deleted immediately.

Add an E-Mail attachment

1. On the **Hotmail** inbox screen, tap **New** located at the bottom of the screen.
2. In **To:** field, enter an e-mail address.
3. In **Subject**, enter the subject of the e-mail.
4. Tap **Menu > Insert > File**, to select a file.
5. Enter a message in the body of the e-mail, and then tap **Send**.



You can also attach **Picture** and **Voice Note** files.

Option and Settings

With **Pocket MSN Options** you can manage your password settings. For instructions, select the task below.

Clear the MSN password last saved on your device

When you clear the password that was last saved on this device, you can re-enter your credentials using a new password. You need to do this if you change the password on your MSN account.

1. On the Home screen, tap Start > Programs > Pocket MSN.
2. Tap Options > General.
3. Tap Clear saved password and tap Done.

Set up an Account

Before you can use MSN Messenger, you must set up an instant messaging account. For MSN Messenger Service, you must have Microsoft Passport Network credentials or a Hotmail account. To use MSN Messenger Service, you need to create a connection to the Internet.

1. In MSN Messenger, tap Menu > Options > Messenger tab.
2. Tap Enable MSN Messenger Service. Your sign-in name and password are established the first time you sign in to Pocket MSN.
3. If necessary, select which account to sign in to first, under Sign in using this account first.

To obtain a Passport, go to <http://www.passport.com>

To create a Hotmail account, go to <http://www.hotmail.com>

Add and Delete Contacts

After you have signed into Messenger, you will be able to perform the functions below.

- To add a contact, tap Menu > Add Contact, and then follow the directions on the screen.
- To delete a contact, select the contact, tap Menu > Delete contact. Tap Yes to permanently delete the contact.

Manage Contacts

- To block a contact from seeing your status and sending you messages, select the contact, and tap Menu > Block.
- To unblock a contact, select the blocked contact from the list, and tap Menu > Unblock.

Change Your Display Name

1. In MSN Messenger, tap Menu > Options.
2. In My display name, enter the name that you want to display to others in MSN Messenger, then tap Done.

Check your own Messenger Status

- Select your own name at the top of the page. Your current status is indicated in the displayed list by a bullet point. You can change your status by selecting another status description.

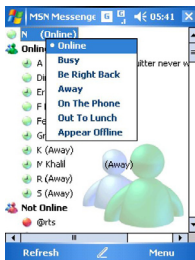

Subscribe to status updates for selected Contacts

When your device has an open data connection, status update notifications alert you when contacts come online or change their MSN Messenger status.

1. Select the contact.
2. Tap Menu > Auto update status.

Let Contacts know you are not available

Select your own name at the top of the page, and then tap the desired status description (such as Away).

Read a Message

- When you receive an alert that a new message has been received, tap Chat to switch to that chat, or Ignore to stay in the current chat.
- To switch between chats, tap Menu > Chats, and then select the contact to resume chatting.

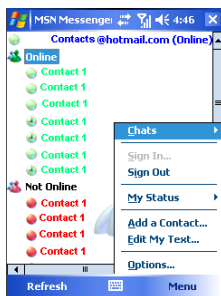

Send a Message

1. Select the contact you want to send a message to.
2. Enter your message in the text entry area at the bottom of the screen and tap Send. To quickly add common message, select Menu > My Text, select a message in the list, and click on it.

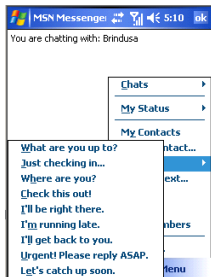

Sign In and Out

1. On the Home screen, tap **Start > Programs > Pocket MSN**.
2. Tap **MSN Messenger > Sign in**.
3. Enter the e-mail address and password for your Microsoft Passport Network credentials or Hotmail account, and tap **Sign in**.



The phone will only prompt for your Sign in account and password the first time you sign in for that account. After a successfully signing in, you will not be prompted for your Sign in details the next time you sign in again. To switch to a different account, you will need to tap **Menu > Options > Switch User**.

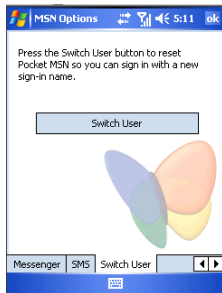

Signing in to an account may take several minutes, depending on your connection speed and how busy your mobile network is.

- To sign out, tap **Menu > Sign out**.

Chapter 6.

Synchronizing

6.1 About ActiveSync
6.2 How to Set Up ActiveSync

6.1 Introduction to ActiveSync

Your device contains ActiveSync software that allows you to create a synchronization relationship between your mobile device and your PC. This means that when your device is connected to your PC, data is shared between your device and PC according to your preferences. If you make a change in one place, the next time you connect PC and device together, the change is automatically made to the corresponding information on the other machine. You may connect to your PC using a cable, or using a Bluetooth connection. Accessing files from your PC remotely on your device is also possible using the 1-View component of i-mate Suite™.

To allow the connection to be made, the ActiveSync software provided on the in-box CD must also be installed on your PC.

To access e-mails or other Outlook information when you are away from your PC, you may also connect your device to your Microsoft Exchange E-mail server. This connection may be performed over GPRS or WiFi, or using your PC as a way of connecting back to the Internet. If your Exchange Server is running Exchange 2003 Service Pack 2, you may also be able to receive Push e-mails, whereby any new e-mails are sent directly to your device.

6.2 Installing and Configuring ActiveSync

You can either install ActiveSync from your Windows Mobile Getting started CD or by downloading from <http://www.microsoft.com/windowsmobile/addons/default.aspx>

After the software has been installed and the USB cable is connected between your PC and the phone, the ActiveSync setup wizard starts up. Click Next to continue.

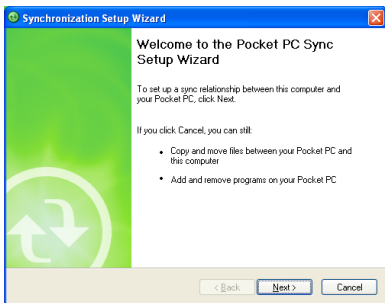

If you only intend to synchronize directly with your Microsoft Exchange Server and not your PC, select the option below. The alternative is to sync your phone with your PC. Note that you cannot do both at the same time while connected to your PC. The next few steps are self-explanatory to follow through from the screen information. Please select the appropriate options required.

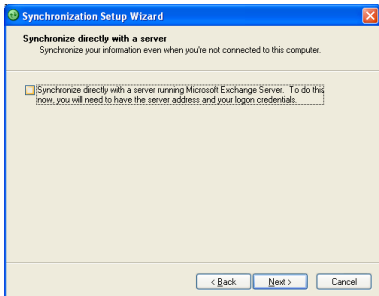



If you have a PC which is already fully synchronized with your Exchange Server, then synchronize your device to your PC the very first time instead of synchronizing through to the Exchange Server. This will allow faster synchronization.

To synchronize direct through to your Exchange Server instead of your PC, click the box above and enter the Exchange Server details as shown below:

Synchronization Setup Wizard

Exchange server credentials
Enter the information that will authenticate you to a server running Microsoft Exchange Server

Server address: Exchange.Server.Address

Note: If you use Outlook Web Access, this is the same as your DWA server address.
 This server requires an encrypted (SSL) connection

Logon Credentials

User name: YourName

Password:

Domain: YourDomainName

Save password (required for automatic synchronization)

< Back Next > Cancel

Ensure that your PC has a connection which is accessible to the Server as the setup will check the connection and that your User name / Password settings above are valid also.

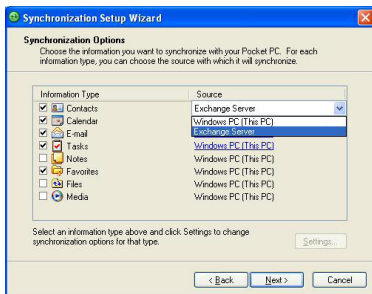

You can view additional settings information by selecting an item and clicking Settings below. For example, you may choose to synchronize details of your Calendar for the past two weeks only:

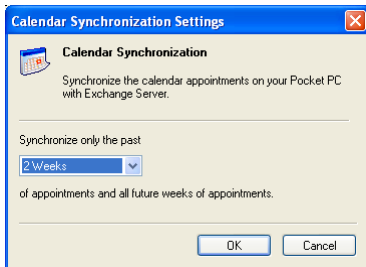

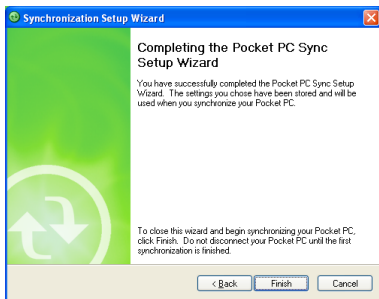

After you click Finish above, you should get a screen prompt as below. This needs to be selected as appropriate to your own requirements depending on the state of your PC.

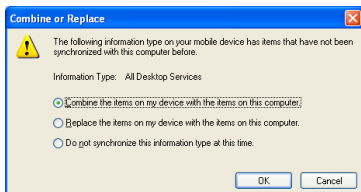

The time required for the synchronization depends on how much data is to be transferred.

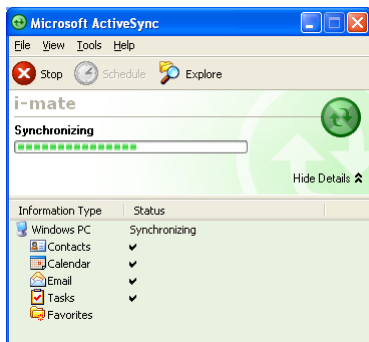

Information Type	Status
Windows PC	Synchronizing
Contacts	✓
Calendar	✓
Email	✓
Tasks	✓
Favorites	

When the synchronization has completed successfully, details from your selected data types will be shown on your Today screen. For example in the diagram below, an upcoming Calendar appointment and unread emails are displayed:

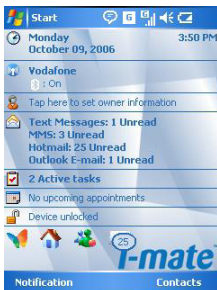

Change ActiveSync settings

After setting up synchronization using the Sync Setup wizard on the PC, the synchronization settings can subsequently be changed:

- If you want to change ActiveSync settings when synchronizing with your PC, use the «Changing the amount of information synchronized» section in the Help files on your PC.

- If you want to change ActiveSync settings for synchronizing through to your Exchange Server, use the ActiveSync settings on your device, as described in «Change settings for an information type.»

Change settings for an information type



Before changing synchronization settings on the device, first disconnect it from your PC.

1. On the phone Today screen, click Start > Programs > ActiveSync > Menu > Options.
2. Select one of the information types.
3. Do one of the following:
 - To view or change settings for an information type (when available), click Settings.
 - To view or change settings for a computer or Exchange Server, click Menu > Settings.
4. Change the amount of information to be synchronized or other settings.
5. Click Done (or Finish in the Exchange Server settings wizard).

Connecting to a PC using Bluetooth

1. Follow the instructions in ActiveSync Help on the PC for configuring Bluetooth on your PC to support ActiveSync. Make sure that your PC's Bluetooth is set to Visible (also known as 'Discoverable'), and that ActiveSync on the PC has the Bluetooth COM port enabled – see below.
2. From the device Today screen, click Start > Programs > ActiveSync.
3. Click Menu > Connect via Bluetooth. Ensure that the phone and PC are within close range.
4. If this is the first time you have connected to this PC via Bluetooth, you must complete the Bluetooth wizard on the phone and set up a Bluetooth partnership with the PC before synchronizing.

5. Click Sync.
6. When finished, click Menu > Disconnect Bluetooth.
7. To preserve battery power, turn off Bluetooth.



Ensure that the PC ActiveSync Serial port corresponds to the PC's Bluetooth Serial port configuration. In the example below the Bluetooth Serial Port has already been set up as COM4 by the computer. Because COM4 is allocated to Bluetooth, the 'Allow connections to one of the following' has been set to 'COM4' to match this.



In the sample screenshot below, the PC Bluetooth Manager indicates the Bluetooth Serial Port is set to COM4.

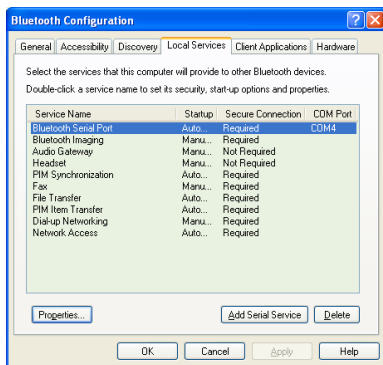

Mixed synchronization settings between Exchange Server and PC

If, for example, you wish to sync your phone to Exchange Server for Email and Tasks, and to your PC for Contacts and Calendar, from your phone, click Start > Programs > ActiveSync > Menu > Options and select from the list as shown. .

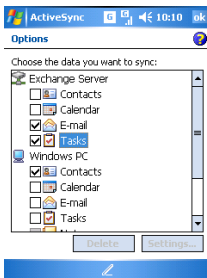

Before connecting your device to your PC, you may first need to check your ActiveSync Connection settings by double clicking on the ActiveSync icon at the bottom right of your PC screen.



When complete, connect your device and synchronization should take place as below.

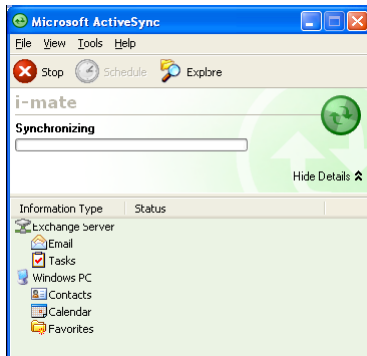

Setting up an Exchange Server connection

You can synchronize your email, Calendar Appointment and Contacts directly with your Exchange server. Tasks may also be synchronized if your company is running Exchange Server 2003 with Service Pack 2.

The synchronization may be performed over the air using a cellular connection, using Wi-Fi to a local Wireless Access Point, or by using your PC as a pass-through. In this final method, you connect your device to your PC and use the PC's connection to the internet as the connection for your device back to the Exchange Server.

To complete this configuration, you will need to get the name of the server and the server domain name from your service provider or system administrator. You must also know your Exchange user name and password.



Before changing synchronization settings on the phone, disconnect it from your PC. You can also refer to some of the screenshots in the previous section of *Install and setup ActiveSync (with Exchange Server)*.

1. On the phone Home screen, click Start > Programs > ActiveSync > Menu > Configure Server. If you have not yet set up sync with Exchange Server, this will say Add Server Source.
2. In Server address, enter the name of the server running Exchange Server, and click Next.
3. Enter your user name, password, and domain name, and click Next.
4. If you want the phone to save your password so that you will not need to enter it again when connecting, select the Save password check box.
5. Select the check boxes for the types of information items that you want to synchronize with Exchange Server.
6. To change available synchronization settings, select the type of information, and click Menu > Settings.
7. To change the rules for resolving synchronization conflicts, click Menu > Advanced.

8. Click Finish.

Start and stop synchronization

1. On the Today screen, click Start > Programs > ActiveSync.
2. To start synchronization, click Sync.
3. To stop synchronizing, click Stop. (Note this menu only shows up during the synchronization)

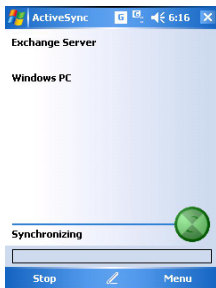

Synchronizing your Music and Video files

Your device is able to synchronize music and video files from your PC. This is described in detail in Chapter 7.

Chapter 7.

Applications & Multimedia

- 7.1 Contacts
- 7.2 Calendar
- 7.3 Tasks
- 7.4 Camera & Video Recorder
- 7.5 Using Pictures & Videos
- 7.6 Using Windows Media Player
- 7.7 Internet Explorer Mobile
- 7.8 Using JAVA
- 7.9 Wireless Manager
- 7.10 Notes
- 7.11 Word Mobile
- 7.12 Wireless Manager
-  7.13 Wireless Manager
- 7.14 Internet Sharing
- 7.15 Using Terminal Services Client
- 7.16 File Explorer



Introduction

Your Pocket PC contains many applications to make you more productive, while at home, in the office or on the move.

Your device comes with mobile versions of Microsoft Word, Excel, Outlook and Powerpoint, as well as Windows Media Player.

You can also take pictures and movies, record notes and use Java applications using the built-in programs.

This chapter will guide you through how to use these applications, and let you know how to add more.

7.1 Contacts

Contacts is your address book and information storage for the people and businesses you communicate with. Store phone numbers, e-mail addresses, home addresses, and any other information that relates to a contact, such as a birthday or an anniversary date. You can also assign a picture or a ringtone to a contact.

From the Contacts list, you can quickly communicate with people. Tap a contact in the list for a summary of contact information. From there, you can call or send a message.

If you use Outlook on your PC, you can synchronize contacts between your device and PC. If you have synchronized your contacts with an Exchange server, then your contacts will be updated there too.

To create a contact

1. Tap Start > Contacts.
2. Tap New and enter the contact information.
3. When finished, tap OK.

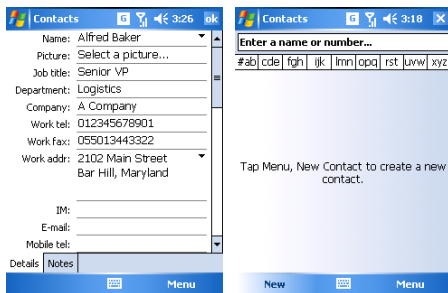

If someone who is not in your list of contacts calls you or sends you a message, you can create a contact from Call History, or from the message by tapping Menu > Save to Contacts.

In the list of contact information, you'll see where you can add a picture or assign a ring tone to a contact.

To change contact information

1. Tap Start > Contacts.
2. Tap the contact.
3. Tap Menu > Edit and enter the changes.
4. When finished, tap OK.

To work with the contact list

There are several ways to use and customize the contact list. Here are a few tips:

1. Tap Start > Contacts.
2. In the contact list, do any of the following:
 - In Name view, you can search for a contact by entering a name or number, or by using the alphabetical index. To switch to Name view, tap Menu > View By > Name.

- To see a summary of information about a contact, tap the contact. From there you can also make a call or send a message.
- To see a list of available actions for a contact, tap and hold the contact.
- To see a list of contacts employed by a specific company, tap Menu > View By > Company. Then, tap the company name.

To find a contact

There are several ways to find a contact when your contact list is long.

1. Tap Start > Contacts.
2. If you are not in Name view, tap Menu > View By > Name.
3. Do one of the following:
 - Begin entering a name or phone number in the provided text box until the contact you want is displayed. To show all contacts again, tap the text box and clear the text, or tap the arrow to the right of the text box.
 - Use the alphabetical index displayed at the top of the contact list.
 - Filter the list by categories. In the contact list, tap Menu > Filter. Then tap a category you've assigned to a contact. To show all contacts again, select All Contacts.

7.2 Calendar

Use Calendar to schedule appointments, including meetings and other events. Your appointments for the day can be displayed on the Today screen. If you use Outlook on your PC, you can synchronize appointments between your device and PC. If you synchronize your calendar over your cellular connection to your email account, then this will also be kept up to date.

You can also set Calendar to remind you of appointments with a sound or flashing light, for example.

You can look at your appointments in several different views (Day, Week, Month, Year, and Agenda).

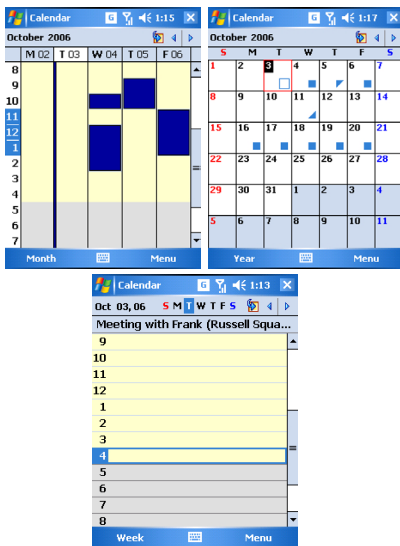

To see detailed appointment information in any view, tap the appointment.

To schedule an appointment

1. Tap Start > Calendar.
2. Tap Menu > New Appointment.
3. Enter a name for the appointment, and enter information such as start and end times.
4. To schedule an all-day event, in the All Day box, tap Yes.

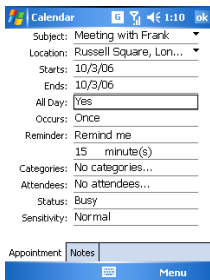

5. When finished, tap OK to return to the calendar.



Note All-day events do not occupy blocks of time in Calendar; instead, they appear in banners at the top of the calendar.

To cancel an appointment, tap the appointment and tap Menu > Delete Appointment.

To have the time entered automatically in Day view, tap the time slot for the new appointment, and tap Menu > New Appointment.

To send a meeting request

Use Calendar to schedule meetings via e-mail with contacts who use Outlook or Outlook Mobile.

1. Tap Start > Calendar.
2. Schedule a new appointment, or open an existing one and tap Edit.
3. Tap Attendees.
4. Tap the name of the contact you want to invite.
5. To invite each additional attendee, tap Add and tap the name.
6. Tap OK.
7. The meeting request will be sent to the attendees the next time you synchronize your device with your PC.



When attendees accept your meeting request, the meeting is automatically added to their schedules. When their response is sent back to you, your calendar is updated as well.

To set a default reminder for all new appointments

You can have a reminder automatically turned on for all new appointments you schedule.

1. Tap Start > Calendar.
2. Tap Menu > Options > Appointments tab.
3. Select the Set reminders for new items check box.
4. Set the time when you want the reminder to alert you.
5. Tap OK to return to the calendar.

7.3 Tasks

Use Tasks to keep track of things you need to do. A task can occur once or repeatedly (recurring). You can set reminders for your tasks and you can organize them using categories. Your tasks are displayed in a task list. Overdue tasks are displayed in red.

To create a task

1. Tap Start > Programs > Tasks.
2. Tap New, enter a subject for the task, and fill in information such as start and due dates, priority, and so on.
3. When finished, tap OK.

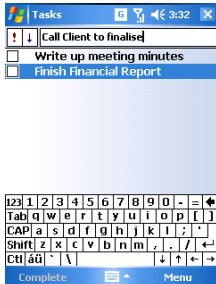



You can easily create a short, to-do-type task. Simply tap the "Tap here to add a new task" box, enter a subject, and press ENTER. If the task entry box is not available, tap Menu > Options and select the "Show Tasks entry bar" check box.

To change the priority of a task

Before you can sort tasks by priority, you need to specify a priority level for each task.

1. Tap Start > Programs > Tasks.
2. Tap the task you want to change the priority for.
3. Tap Edit and in the Priority box, tap a priority level.
4. Tap OK to return to the task list.



All new tasks are assigned a Normal priority by default.

You can have a reminder automatically turned on for all new tasks you create.

1. Tap Start > Programs > Tasks.
2. Tap Menu > Options.
3. Select the Set reminders for new items check box.
4. Tap OK to return to the task list.

Tasks 3:33

Subject: Finish Financial Report

Priority: High

Status: Not Completed

Starts: None

Due: None

Occurs: Once

Reminder: Remind me

10/3/2006 8:00 AM

Categories: No categories...

Sensitivity: Normal

Task Notes Menu



The new tasks must have due dates set in order for the reminder to take effect.

To show start and due dates in the task list

1. Tap Start > Programs > Tasks.
2. Tap Menu > Options.
3. Select the Show start and due dates check box.
4. Tap OK.

To locate a task

When your list of tasks is long, you can display a subset of the tasks or sort the list to quickly find a specific task.

1. Tap Start > Programs > Tasks.
2. In the task list, do one of the following:
 - Sort the list. Tap Menu > Sort by, and tap a sort option.
 - Filter the list by category. Tap Menu > Filter, and tap the category you want displayed.



To filter your tasks further, tap Menu > Filter > Active Tasks or Completed Tasks.

7.4 Camera and Video recorder

Taking photos and recording video clips along with audio is easy with your device's built-in camera.



To start the Camera

- Tap Start > Programs > Camera; or
- Press the camera button on your device.



Use the camera

The camera on your device allows you to capture pictures and video clips by using various built-in modes with flexibility. The Camera mode is set to the Photo capture mode by default. By using either the navigation keys or tapping the screen you can adjust the various options.

- Tap  or  on the screen.
- Press NAVIGATION left or right.
- Photo: Captures standard still images.
- Video: Captures video clips, with or without accompanying audio.
- Portrait: Captures self portraits
- Self Shutter: Captures a still image
- Burst: Captures a sequence of still images (maximum 30) as long as CAMERA on the device or ENTER on the NAVIGATION is kept pressed.

Use shortcuts in Camera mode

- While in Camera mode, you can use the following buttons and icons on your device as a shortcut when performing operations.
- The ENTER button
- Press ENTER to take a picture when you are capturing still image. Press ENTER to start recording an incoming video stream; press it again to stop recording.

The NAVIGATION control

- Press NAVIGATION up or down to swap between setting the Saturation, Contrast, Brightness Effect, Environment and Zoom of the current picture.
- Press NAVIGATION left or right to alter whichever setting has been chosen by the up and down arrows.

For example, press the NAVIGATION up until you arrive at the 'Brightness' setting. Now press the left arrow to decrease the brightness of the picture, or the right arrow to increase the brightness.

The CAMERA button

Press the CAMERA button on the device to switch to Camera mode. If already in Camera mode, press once to take a still image or to start recording a video clip.

Use Still Image capture modes

While using Still Image capture modes, such as Photo, Self Portrait, Self Shutter, and Burst, you can capture still image(s) by pressing the CAMERA or ENTER buttons on the device, or tapping Capture on screen. The Still Image capture creates JPEG images.

While capturing an image in the Picture Theme capture mode, you can select a built-in template from the default template folder. To browse and select different templates, tap the template selector icon or tool icon to select a template from the Camera Settings screen.

Picture Resolution.

Your device is equipped with a 2 Megapixel camera and can capture pictures in sizes from 0.02 Megapixels up to 2 Megapixels. The larger the number of megapixels, the more detailed the picture will be. However a larger picture means that more data has to be stored, resulting in less free space for other pictures.

To set the resolution of the pictures to be captured, go to Menu > Settings and choose from the drop down menu underneath the Resolution heading.

Use Video capture mode

Your device is capable of recording moving pictures and sound.

To enter into Video recording mode:

1. Press the CAMERA key, then press Menu > Mode > Video or
2. Go to Start > Programs > Camera the press Menu > Mode > Video

While using the Video capture mode, you can press CAMERA or ENTER to start recording a video clip (with audio if desired). To stop recording, press CAMERA or ENTER again. Your device displays the first frame of the captured video clip by default on the Review screen.

Before you capture a video clip, you can specify the recording limit in terms of time and file size on the Camera Settings screen so that the recording stops automatically when the clip size reaches that limit.

To set the limit on the maximum video recorded:

1. Press Menu > Setting
2. Tap on Capture Time Limited, and choose '15 seconds', '30 seconds' or 'Unrestricted'

Video is captured by default as a WMV (Windows Media Video) file. This can be played back on your Pocket PC or on a desktop PC.

Using the Zoom feature

The device is equipped with a digital zoom feature. While capturing a still image or a video clip by using the main camera, you can zoom in to make the object appear larger, and you can zoom out to make the object move farther away. The amount of digital zoom that can be applied depends on the resolution of the picture that is being captured.

The zooming allowed for each picture size is in the table below:

This picture size	Allows this amount of Zooming
1600 x 1200	1x
1280 x 960	1x , 2x
640 x 480 or less	1x, 2x, 3x, 4x

Use the Camera Settings screen

While capturing a still image or video clip using any capture modes, tap the menu item to access the Camera Settings screen. The Camera Settings screen allows you to configure the capture settings.

You can configure the following settings on the Camera Settings screen.

Setting	Allows you to
Capture mode	Select a capture mode
Zoom	Select zoom ratio
Environment	Select the lighting conditions
Effect	Select a effect to apply to the photo/video
Setting	Specify settings and location of files
Album	Browse photos/videos
Exit	Exit

After you configure settings, tap OK or Start Camera on the Camera Settings screen to go back to the Camera screen.

To exit the Camera

- Tap the OK button at the top right of the Camera screen.

7.5 Using Pictures & Videos

The Pictures and Videos program collects, organizes, and sorts images and video clips in the following formats on your device.

File Type	File Extensions
Image	*.bmp, *.jpg
Video	*.avi, *.wmv,

You can view the pictures as a slide show, beam them to another nearby device, send them via e-mail, edit them, or set them as the background on the Today screen.

To copy a picture or video clip to your device

You can copy pictures from your PC and view them on your device.

- Connect your device to your PC using ActiveSync. You can find out more about how to do this in chapter 6. Then drag the images from your PC and place them in the 'My Pictures' folder of your Pocket PC.

For more information about copying files from your PC to your device, see ActiveSync Help on your PC.



You can also copy pictures from your PC to your device using a memory card. Insert the memory card into the memory card slot on your device, then copy the pictures from your PC to the folder you created on the memory card.

To view pictures

1. Tap Start > Programs > Pictures & Videos. The images in the My Pictures folder appear as thumbnails by default.
2. Select a picture and tap View. If you cannot find a picture in the default My Pictures folder, go to another folder by tapping the on the **My Pictures** icon. A list of other folders will be displayed. Click on a folder name to navigate to it.

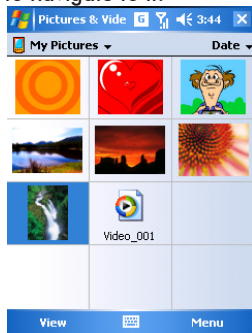

Pictures and Videos

To play videos with audio

1. Tap Start > Programs > Pictures & Videos. The video files in the My Pictures folder appear as thumbnails by default, which appear with a media icon ().
2. Select a video and tap the thumbnail to play it with the built-in Windows Media Player.

To view slide shows

You can view your pictures as a slide show on your device. Pictures are shown in full-screen view with 5-second intervals between slides.

1. Tap Start > Programs > Pictures & Videos.
2. Tap Menu > Play Slide Show.



You can specify how pictures are scaled to optimize their display in a slide show. Tap Menu > Options, then tap Portrait Pictures or Landscape Pictures on the Slide Show tab

Tap anywhere on the screen to display the Slide Show toolbar, which you can use to stop or pause the slide show, rotate the view, and more. Press NAVIGATION right or left to move forward or backward through the slides.

To sort pictures and video clips

If you store a large number of pictures or video clips on your device, you may find it helpful to sort them to quickly find a specific picture or clip. You can sort by name, date, and size.

1. Tap Start > Programs > Pictures & Videos.
2. Tap the sort list (labeled Date by default), and select the item you want to sort by.

To delete a picture or video clip

Do any of the following to remove a picture or a video clip:

- Select a picture or video clip on the Pictures & Videos screen, and tap Menu > Delete. Tap Yes to confirm the deletion.
- Tap and hold the thumbnail of the picture you want to delete, then tap Delete.

To edit a picture or video clip

You can rotate, crop, and adjust the brightness and color contrast of your pictures.

1. Tap Start > Programs > Pictures & Videos.
2. Tap the picture you want to edit.
3. Tap Menu > Edit, and do any of the following:
 - To rotate a picture 90 degrees counterclockwise, tap Rotate.
 - To crop a picture, tap Menu > Crop. Then, tap and drag to select the area to crop. Tap outside the box to stop cropping.
 - To adjust the brightness and contrast levels of a picture, tap Menu > AutoCorrect.
 - To undo an edit, tap Menu > Undo. To cancel all unsaved edits you made to the picture, tap Revert to Saved.

To set a picture as the Today screen background

You can use a picture as the background on the Today screen.

1. Tap Start > Programs > Pictures & Videos.
2. Select the picture you want to set as the background.
3. Tap Menu > Set as Today Background.
4. In Transparency level, select a higher percentage for a more transparent picture, or a lower percentage for a more opaque picture.
5. Tap OK.

To send pictures and video clips via e-mail

1. You can send pictures and video clips to other devices via e-mail.
2. First, set up Messaging to send and receive messages.
3. From the program, select the item you want to send.
4. Tap Menu > Send, and select one account (such as Outlook E-mail or MMS) to send the attached item.
5. A new message is created with the item attached.
6. Enter the recipient name and subject, and tap Send. The message will be sent the next time you synchronize your device.



Pictures and video clips are saved automatically before they are sent.

To assign pictures to contacts

You can assign a picture to a contact. This picture will be shown alongside the contact's name : for example when you receive a telephone call from the contact, or write an email to them.

1. Tap Start > Programs > Pictures & Videos.
2. Select the picture you want to assign to a contact.
3. Tap Menu > Save to Contact.
4. Tap the contact, or navigate and tap Select to choose the contact from your Contacts list.

To use advanced options of the Pictures and Videos program

1. Tap Start > Programs > Pictures & Videos.
2. Select the picture for which you want to configure further settings.
3. Tap Menu > Options. The Options screen appears, allowing you to:
 - Resize a picture so that you can send it faster to someone using your e-mails.
 - Configure the view settings during slide shows and activate screensaver options.
 - Configure your device camera and Video Recorder settings.

7.6 Using Windows Media Player





You can use Microsoft Windows Media Player 10 Mobile for Pocket PC to play digital audio and video files that are stored on your device or on a network.







Using Windows Media Player, you can play both audio and video files. These are the following file formats that are supported by this version of Windows Media Player.

File Formats Supported	File Extensions
Video	
• Windows Media Video	*.wmv, *.asf
• MPEG4 Simple Profile	*.mp4
• H.263	*.3gp
• 3GPP2	*.3g2
Audio	
• Windows Media Audio	*.wma
• MP3	*.mp3
• MIDI	*.mid, *.midi, *.rmi
• AMR Narrow Band	*.amr
• AMR Wide Band	*.awb
• AAC	*.m4a

About the controls

The following are available controls on the Windows Media Player.

This control	Does this	This control	Does this
	Plays a file.		Increases the volume level.
	Pauses a file.		Decreases the volume level.

This control	Does this	This control	Does this
	Skips to the beginning of the current file or to the previous file.		Turns the sound on or off.
	Skips to the next file.		Displays a video by using the entire screen (full screen)
	Adjusts the playback progress of a selected file.		Displays a Web site where you can find music and videos to play.



You can rewind and fast-forward files by pressing and holding the Left/Right sides of the navigation keys.

About the screens and menus

Windows Media Player has three primary screens: the Playback Screen, the Library Screen, and the Now Playing screen. At the bottom of each screen is an option called Menu. The commands on this menu change depending upon which screen you are viewing.

Playback screen

The default screen that displays the playback controls (such as Play, Pause, Next, Previous, and Volume). If the playback is of an audio file, any album art will be shown in this screen. If the file is a video, the pictures will be shown here. You can change the appearance of this screen by choosing a different skin.



When you are viewing the Playback screen, the following commands appear on Menu.

This control	Does this
Library	Displays the Library screen so you can choose a file to play.
Play/Pause	Starts or pauses playback.
Stop	Stops playback.
Shuffle/ Repeat	Plays the items in the Now Playing playlist randomly/ repeatedly.
Full Screen	When a video is playing, pressing this will use the entire screen to play it back. Touch the screen to return to the Playback screen.

Options	Lets you adjust various Windows Media Player options, including network, skin, and hardware button options.
Properties	Displays information about the currently playing file.
About	Displays information about Windows Media Player, such as the version number.

Now Playing screen menu

The screen that displays the Now Playing play list. This special play list indicates the currently playing file and any files that are “queued up” to play next.

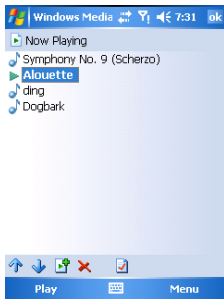

When you are viewing the Now Playing screen, the following commands appear on Menu.

This control	Does this
Library	Displays the Library screen so you can choose a file to play.
MoveUp/ Down	Moves the selected item up/down in the playlist order.
Remove from Playlist	Deletes the selected item from the playlist.
Shuffle/ Repeat	Plays the items in the Now Playing playlist randomly/ repeatedly.

Clear Now Playing	Deletes all items from the Now Playing playlist.
Error Details	Displays error information about the selected item (an exclamation mark appears before the item name if error details are available).
Properties	Displays information about the selected file.

Library screen

The screen that lets you quickly find your audio files, video files, and playlists. It contains categories such as My Music, My Video, My TV, and My Playlists.

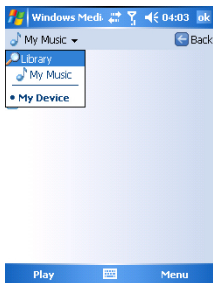

When you are viewing the Library screen, the following commands appear on Menu.

This command	Does this
Queue Up	Adds the selected item to the end of the current (Now Playing) playlist.
Delete from Library	Deletes the selected item from the library.
Now Playing	Displays the Now Playing screen.
Library	Displays the Library screen so you can choose a file to play.

Update Library	Adds new items to the library by searching your device or storage card.
Open File	Lets you find and play files that are stored on your device or storage card but that are not in the library..
Open URL	Lets you play a file on a network, such as the Internet.
Properties	Displays information about the selected file.

About licenses and protected files

Some content (such as digital media files downloaded from the Internet, CD tracks, and videos) have associated licenses that protect them from being unlawfully distributed or shared. Licenses are created and managed by using digital rights management (DRM), which is the technology for securing content and managing its access rights. Some licenses may prevent you from playing files that have been copied to your device. Files that have licenses associated with them are called “protected files.”

If you want to copy a protected file from your PC to your device, use the desktop Player to synchronize the file to your device (instead of dragging the file from a folder on your PC to a folder on your device, for example). This will ensure that the license is copied along with the protected file. For more information about synchronizing files to your device and other mobile devices, see desktop Player Help.



You can view the protection status for a file by checking its file properties (tapping Menu > Properties).

To play items on your device

Use the library to find and play songs, videos, and playlists that are stored on your device or removable storage card.

1. If you are not on the Library screen, tap Menu > Library.
2. On the Library screen, tap the Library arrow (near the top of the screen), then tap the library that you want use (for example, My Device or Storage Card).
3. Tap a category (for example, My Music or My Playlists), tap and

hold the item that you want to play (such as a song, album, or artist name), then tap Play.



To play a file that is stored on your device but is not in a library, on the Library screen, tap Menu > Open File. Tap and hold the item that you want to play (such as a file or a folder), then tap Play.

To play an item on a network

Use the Open URL command to play a song or video that is stored on the Internet or on a network server.

1. If you are not on the Playback screen, tap OK to close the current screen and display the Playback screen.
2. Tap Menu > Open URL.
3. Do one of the following:
 - In the URL box, enter a network address.
 - In the History box, tap a URL that you have previously used.



To play an item on a network, you must be connected to a network. For more information about creating a remote connection between your device and a network, see the Getting Connected chapter in this manual and the Connections help on the device.

Copying files to your device

Use the latest version of the desktop Player (Windows Media Player 10 or later) to synchronize digital media files to your device (instead of dragging a file from a folder on your PC to a folder on your device, for example). Using the desktop Player ensures that licenses are copied with protected files.

When synchronizing files, always synchronize the files to a storage card that is inserted into your device. Do not synchronize to a storage card that is inserted into a storage card reader. In addition, do not synchronize to the internal storage location in your device. For more information about synchronizing files to mobile devices, see desktop Player Help on the PC.



Audio files copy faster if the desktop Player is configured to automatically set the quality level for audio files copied to your device. For more information, see desktop Player Help on the PC.

Troubleshooting

If you encounter a problem while using the Windows Media Player, a number of resources are available to help you troubleshoot the issue. For more information, see the Troubleshooting Windows Media Player Mobile page at the Microsoft Web site (<http://www.microsoft.com/windows/windowsmedia/player/windowsmobile/troubleshooting.aspx>).

7.7 Internet Explorer Mobile

Internet Explorer Mobile is a full-featured Internet browser, optimized for use on your mobile device.

To start Internet Explorer Mobile

- From the Today Screen tap Start > Internet Explorer., or
- Tap the Internet Explorer key on the front of the device



To Use Internet Explorer

Typing in a web page location

To go to a web site, tap in the address bar and enter the address of the site. Press the green arrow to the right of the address bar to go there, or press 'Go' which appears on the bottom left menu option when you have typed in the new address.

Going to a web site using the Favorites list

You can store the web sites you want to visit most frequently in the Favorites list. This list can also be synchronized with your PC so that Favourites in your PC are also carried with you on your Pocket PC.

To open the Favorites list

Inside Internet Explorer Mobile, press Menu > Favorites...

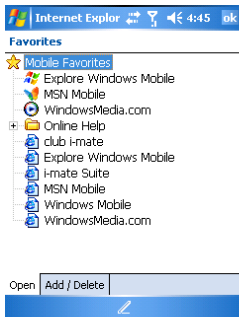

To go to a web page on the Favorites list

Tap on the name of the link to go to that web page.

To Edit the Favorite list

With the Favorites list open, click on the 'Add/Delete' tab at the bottom of the screen. You may select links, edit their names, delete them or add new links.

To Add the current web page to the Favorites list

1. Navigate to a page you wish to appear on the Favorites list.
2. Tap Menu > Add to Favorites...

To transfer favorites from your PC

You can transfer the favorites you have stored on your PC to your device by synchronizing the Internet Explorer favorites on your PC with your device.

1. In ActiveSync on your PC, on the Tools menu, click Options, and select Favorites.
2. In Internet Explorer on your PC, save or move favorite links to the Mobile Favorites subfolder in the Favorites list.
3. Connect your mobile device to your PC. If synchronization does not start automatically, click Sync.

To choose a Home page

1. In Internet Explorer Mobile, tap Menu > Tools > Options > General tab.
2. Do one of the following:
 - To use the displayed page as your Home page, tap Use Current.
 - To use the default Home page, tap Use Default.



To your Home page, tap Menu > Home.

To change the size of text on Web pages

- In Internet Explorer Mobile, tap Menu > Zoom, and tap the size you want.

To show or hide pictures on Web pages

- In Internet Explorer Mobile, tap Menu > View > Show Pictures.
A check mark next to Show Pictures indicates that pictures will be displayed on Web pages.

To change how Web pages fill the screen

1. In Internet Explorer Mobile, tap Menu > View.
2. Tap one of the following:
 - One Column. Arranges the content into one column that is as wide as the screen. This means that you will rarely have to scroll horizontally.
 - Default. Maintains a layout similar to what you see on a desktop computer, but it makes items smaller and arranges the content so that you can see most of it without having to scroll horizontally.
 - Desktop. Keeps the same layout and size as on a desktop computer, which will require both horizontal and vertical scrolling.



To clear the History list

1. In Internet Explorer Mobile, tap Menu > Tools > Options > Memory tab.
2. Tap Clear History.

To save a picture from a Web page

1. In Internet Explorer Mobile, tap and hold the picture, and tap Save Image.
2. Do one of the following:
 - To save the picture in My Pictures on your device, tap Yes.
 - To save the picture in another location, such as a storage card, tap Save As.

To change cookies and security settings

Internet Explorer Mobile supports the protocols used by Secure Sockets Layer (SSL). A connection that uses SSL helps you to send personal information more safely.

Cookies are small files containing information about your identity and preferences so that a page can tailor information to your needs. The page sends the file, and it is stored on your mobile device.

1. In Internet Explorer Mobile, tap Menu > Tools > Options > Security tab.
2. Select the check boxes for the options you want, and tap OK.



To prevent Internet Explorer Mobile from accepting any cookies, clear the Allow cookies check box.

To delete temporary Internet files

Some Web content is stored as you view it to speed up the display of pages you frequently visit or have already seen. You may want to delete these files to free storage space.

1. In Internet Explorer Mobile, tap Menu > Tools > Options > Memory tab.
2. Tap Delete Files. All pages stored on your device, including offline favorites content, will be deleted.



To end the GPRS session that was initiated from within the Internet Explorer Mobile browser, press and hold the End (Call Hang up) button until the GPRS connection is closed down.

7.8 Using Java

MIDlets are Java applications that can run on mobile devices. Your device supports Java 2 Micro Edition, J2ME. The Java software allows you to download Java applications, such as games and tools that are specifically designed for mobile devices. This gives you the flexibility of installing and managing additional J2ME applications from the Internet.

To install MIDlets from the Internet

1. Locate the MIDlet/MIDlet suite while connected to the Internet.
2. Select the MIDlet/MIDlet suite to download.
3. Confirm to start downloading.
4. Run the file(s) to install.

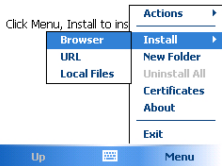

You can cancel the installation at any time.

To install MIDlets from a PC

You can install the MIDlets/MIDlet suites on your device from a PC using the USB sync cable, the optional cradle, or Bluetooth. MIDlets copied to your device using Bluetooth, or e-mail attachments are automatically saved in the My Documents folder. However, you can copy the MIDlet file(s) from a PC to any of the following temporary folders on your device from where MIDlet Manager can install them.

- Device memory: ../My device/My Documents/My MIDlets
- Storage card: ../My device/Storage Card



If the My MIDlets folder does not exist in My Documents, you can create one with the same folder name. However, a folder named Storage Card automatically appears after you insert a storage card into your device.

To install a MIDlet/MIDlet suite

1. Tap Start > Programs > Java > Menu > Install > Local Files to install the MIDlets currently saved on your phone.
2. Select the MIDlet/MIDlet suite from the list by using the NAVIGATION control.
3. Tap Install.
4. Tap OK to install.
5. Tap Continue to confirm the installation.



To remove the MIDlet files from the temporary folder, tap Delete from the shortcut menu.

To run MIDlets on your device

1. Tap Start > Programs > Java.
2. Select a MIDlet from the list by using the NAVIGATION control.
3. Press the ENTER button to run the MIDlet.

Manage MIDlets

You can organize the MIDlets into folders in order to find them easily. You can create a folder by:

1. Clicking Menu > New Folder.
2. Type in the name of the folder
3. Press Create
4. To enter inside that folder, tap on its name. To leave that folder, click on the '..' icon

To change the display name of a MIDlet

1. Tap Start > Programs > Java.
2. Select a MIDlet by using the NAVIGATION control.
3. Tap Menu > Actions > Rename.
4. Enter a new name for the MIDlet.
5. Tap Save.



You cannot change the name of a MIDlet suite.

To uninstall a MIDlet

1. On the Java Apps screen, select the MIDlet/MIDlet suite by using the NAVIGATION control.
2. Tap Menu > Actions > Uninstall.
3. Tap OK to confirm.



You cannot uninstall a single MIDlet from a MIDlet suite; you must uninstall the complete MIDlet suite.

To configure MIDlet security

You can adjust security settings for each MIDlet/MIDlet suite.

1. On the Java Apps screen, select a MIDlet by using the NAVIGATION control.
2. Tap Menu > Actions > Security.
3. Configure the security options, such as Local connection, Net access, Auto start.

Following are the security options that you can set for a running MIDlet/MIDlet suite.

Security Option	Description
Net Access	Determines whether a MIDlet/MIDlet suite can access the Internet.
Local Connection	Enables a MIDlet/MIDlet suite to access services, such as Bluetooth.
Auto start	Enables a MIDlet/MIDlet suite to run at specified times, or any time.

7.9 Wireless Manager

The Wireless Manager is an application that allows you to easily switch on and off the Bluetooth, Wi-Fi and Telephony functions of your Pocket PC.

To Start the Wireless Manager

- From the Today screen, tap on the antenna symbol at the top of the screen and select Wireless Manager, or
- From the Today Screen go to Start > Settings > Connections tab > Wireless Manager



If an item is active then it will be colored white. If an icon is dark then it is inactive. In the example above, both the telephone and Bluetooth functions are active, whilst the Wi-Fi is off.

To turn the Telephony Element on and off

You may switch the Telephony element of your Pocket PC on and off by tapping on the 'Phone' item. When a cross appears on the receiver icon, the device is in 'flight mode' for the telephone element only. You will not be able to make or receive telephone calls, nor use the cellular data network of your Mobile Operator. However, Bluetooth and Wi-Fi may still be activated if you so wish.

To turn the telephony element back on, click the option again.

To disconnect the current active cellular data connection

You may wish to disconnect the cellular data connection without switching off the telephone function. To do this tap Menu > Disconnect Cellular Data

The data connection will automatically reconnect itself if you are using the Direct Push email solution. This is by design as your device must have a connection permanently to the email server. If you wish to disconnect the data connection under this scenario, first you must disconnect the Direct Push email. To do this:

1. From the Today Screen go to Start > Programs > ActiveSync.
2. Tap Menu > Schedule
3. Change the 'Peak times' and 'Off Peak Times' to the 'Manually' setting

Now you may return to the Wireless Manager to disconnect the cellular data.

When you wish to restart the Direct Push email again, you should return to the ActiveSync Schedule page and re-choose 'As Items Arrive'.

To Turn Bluetooth On and Off

Tap on the Bluetooth menu option

To set up the advanced features of Bluetooth, click on Menu > Bluetooth Settings

To Turn Wi-Fi On and Off

Tap on the Wi-Fi menu option

To set up the advanced features of Wi-Fi, click on Menu > Wi-Fi Settings

7.10 Notes

Notes helps you to quickly capture thoughts, questions, reminders, to-do lists, and meeting notes. You can create handwritten and typed notes, record voice notes, convert handwritten notes to text for easy readability, and send notes to others.

Entering information in Notes

There are several ways to enter information in a note. You can enter typed text by using the on-screen keyboard or handwriting recognition software. You can also use the stylus to write or draw directly on the screen. On devices that support recording, you can create a stand-alone recording or embed a recording in a note.

To set the default input mode for Notes

If you frequently add drawings to your notes, you may find it helpful to set Writing as the default input mode. If you prefer typed text, select Typing.

1. Tap Start > Programs > Notes.
2. In the note list, tap Menu > Options.
3. In the Default mode box, tap one of the following:
 - Writing if you want to draw or enter handwritten text in a note.
 - Typing if you want to create a typed note.
4. Tap OK.

To create a note

1. Tap Start > Programs > Notes. In the note list, tap New.
2. Tap the Input Selector arrow next to the Input Method icon on the menu bar, tap the input method you want, and enter your text.
3. If the Input Selector arrow is not displayed, tap the Input Method icon.
4. When finished, tap OK to return to the note list.

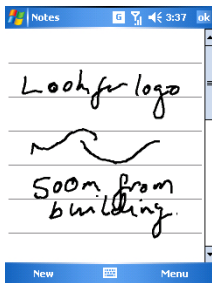

7.11 Word Mobile

Word Mobile is a pocket-based version of Microsoft Word. Word documents created on your PC can be opened and edited on your device. You can also create and edit documents and templates in Word Mobile and save them as *.doc, *.rtf, *.txt, and *.dot files.

You can have only one document open at a time. When you open a second document, the first one is saved and closed automatically.

When you close a newly created document, it is automatically named after the first several words in the document and placed in the Word Mobile document list. You can easily rename the document with a more meaningful name and move it to another folder or a storage card.

To create a file

1. In Word Mobile, tap New.
2. You'll see either a blank document or template, depending on what you've selected as the default template.
3. Enter text as desired.
4. When finished, tap OK to save the file.



Unsupported features in Word Mobile

Word Mobile does not fully support some features of Microsoft Word such as revision marks and password protection. Some data and formatting may be lost when you save the document on your device.

The following features are not supported in Word Mobile.

- Backgrounds
- Shapes and text boxes
- Artistic page borders
- Smart tags
- Metafiles
- Bi-directional text. While Word Mobile will open documents containing bi-directional text, the indentations and alignment may be displayed and saved incorrectly.
- Password-protected files. Word Mobile does not support opening password-protected documents. You must first remove the password

protection in Word on the PC if you want to view the document on the device.

- Document protection. Word Mobile does not support displaying files that have been protected in Word on the PC.

The following features are partially supported in Word Mobile.

- Picture bullets
- Revision marks
- Table styles
- Underline styles. Underline styles not supported by Word Mobile are mapped to one of the four supported styles: regular, dotted, wavy, or thick/bold/wide.
- Legacy Pocket Word files. You can open *.psw files in Word Mobile; however, if you edit a file, you will need to save it in *.doc, *.rtf, *.txt, or *.dot format.

The following features are not supported on the device; however, they are retained in the file so that when a file is opened on the PC again, they appear as expected.

- Footnotes, endnotes, headers, footers
- Page breaks
- Lists
- Fonts and font sizes. Fonts not supported by the device are mapped to the closest font available, although the original font will be listed on the device.

To get more help about Word Mobile

- When in Word Mobile, tap Start > Help.

7.12 Excel Mobile

Excel Mobile makes it easy for you to open and edit Excel workbooks and templates created on your PC. You can also create new workbooks and templates on your device.

To Run Excel Mobile

Tap Start > Programs > Excel Mobile

The program operates much as the desktop PC version, allowing entry of numbers, formulae, text, sorting and autofiltering.

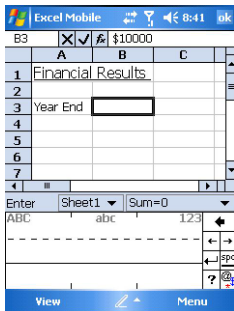

To create a new Workbook

Press Menu > New

To Send a Workbook

To send to another device nearby, you may use Bluetooth beaming

1. Go to Menu > File > Beam...
2. Select the device to which you want to beam the file

To send via a messaging account

You may send the file via email or MMS to another user

1. Tap Menu > File > Send...
2. Choose the account from which you wish to send the file (e.g. Outlook, Hotmail, MMS, etc)
3. Type in the recipient address into the email. The file is already attached.
4. Press Send



Work in full-screen mode to see as much of your workbook as possible. Tap View > Zoom and select a percentage so that you can easily read the worksheet.

Unsupported features in Excel Mobile

Excel Mobile does not fully support some features such as formulas and cell comments. Some data and formatting may be lost when you save the workbook on your device. Note the following Excel Mobile formatting considerations:

- Alignment. Horizontal, vertical, and wrap-text attributes remain the same, but vertical text appears horizontal.
- Borders. Appear as a single line.
- Cell patterns. Patterns applied to cells are removed.
- Fonts and font sizes. Fonts not supported by your device are mapped to the closest font available. The original font is listed on your device. When the workbook is opened in Excel on your PC again, the data is displayed in the original font.
- Number formats. Numbers formatted using the Microsoft Excel 97 conditional formatting feature are displayed in Number format.
- Formulas and functions. If an Excel file contains a function that is not supported by Excel Mobile, the function is removed, and only the returned value of the function appears. The following formulas are also converted to values: formulas entered as an array or containing an array argument, for example, =SUM({1;2;3;4}); formulas containing external link references or an intersection range reference; and formulas containing references past row 16384 are replaced with #REF!
- Protection settings. Most worksheet and workbook protection features are disabled but not removed. However, support for password protection has been removed. Workbooks that are password-protected or workbooks in which one or more worksheets are password-protected cannot be opened. You must remove the

password protection in Excel on the PC and then synchronize to open the file on the device.

- **Zoom settings.** Are not retained. Excel supports a per worksheet zoom setting, while the Excel Mobile zoom setting is applied to the entire workbook.
- **Worksheet names.** Names that reference worksheets within the same workbook are displayed accurately, but names that refer to other workbooks, arrays, for example, `={1;2;3;4}`, array formulas, or intersection ranges are removed from the name list. If a name is removed from the list, it is left in formulas and functions, causing those formulas to be resolved as “#NAME?” All hidden names are not hidden.
- **AutoFilter settings.** These are removed. However, you can use the AutoFilter command in Excel Mobile to perform similar functions. If you have an AutoFilter applied to a worksheet that causes rows to be hidden, the rows remain hidden when the file is opened in Excel Mobile. Use the Unhide command to display the hidden rows.
- **Chart formatting.** All charts will be saved the way they are shown in Excel Mobile. Unsupported chart types are changed to one of these supported types: Column, Bar, Line, Pie, Scatter, and Area. Background colors, gridlines, data labels, trend lines, shadows, 3D effects, secondary axes, and logarithmic scales are turned off.
- **Worksheet features.** The following features are not supported in Excel Mobile and are removed or modified when a workbook is opened on the device: hidden sheets are not hidden; VBA modules, macro sheets, and dialog sheets are removed and replaced with a place holder sheet; text boxes, drawing objects, pictures, lists, conditional formats, and controls are removed; pivot table data is converted to values.

7.13 Viewing Slide Shows with PowerPoint Mobile

With PowerPoint Mobile, you can open and view slide show presentations created on your PC in *.ppt and *.pps format with PowerPoint 97 and later. Many presentation elements built into the slide shows such as slide transitions and animations will play back on the device. If the presentation is set up as a timed slide show, one slide will advance to the next automatically. Links to URLs are also supported. PowerPoint features not supported on the device include:

- Notes. Notes written for slides will not be visible.
- Rearranging or editing slides. PowerPoint Mobile is a viewer only.
- File formats. Files created in *.ppt format earlier than PowerPoint 97 and HTML files in *.htm and *.mht formats are not supported.

To start a slide show presentation

1. Tap Start > Programs > PowerPoint Mobile.
2. In the presentation list, tap the slide show you want to view.
3. Tap the current slide to advance to the next slide.

If the presentation is set up as a timed slide show, slides will advance automatically.

To stop a slide show

- In a PowerPoint Mobile presentation, tap > End Show.

To navigate between slides

You can advance to the next slide if a presentation is not set up as a timed slide show, return to the previous slide, or go to any slide out of sequence.

1. Tap Start > Programs > PowerPoint Mobile.
2. Open the presentation you want to view.
3. Tap > Next or Previous, or tap Go to Slide and tap the slide you want to view. Simply tap the current slide to advance to the next slide. Note if you have zoomed in to see a slide in more detail, you

cannot navigate to another slide until you zoom out. Tapping Next or Previous may play an animation on a slide rather than navigate to another slide.

7.14 Internet Sharing

Internet sharing is a way of using your Pocket PC as a cellular modem for your laptop or desktop PC. Here, we provide a brief overview to the subject. You can find step-by-step guidelines for configuring your device for use as a Wireless Modem on <http://www.clubimate.com> and on the companion CD that came with your device.



Your cellular account must already be enabled with a data plan.

To start Internet Sharing

From the today Screen, tap Start > Programs > Internet Sharing



You should choose how you wish to connect your desktop/laptop PC to your Pocket PC.

In the PC connection field choose either 'USB' for a wired connection, or 'Bluetooth PAN' to join the two together using Bluetooth.

Next, you must choose the data connection that you will use to connect to the internet. You can choose this from a drop-down list of all connections that have been configured. If you have not already set up a connection for accessing the internet, please refer to chapter 4 'Getting Connected'.

If you have chosen to connect over USB

1. Press the 'Connect' button at the bottom of the screen.
2. Now connect your Pocket PC to your desktop/laptop PC using the USB cable supplied.
3. The Pocket PC will show the word 'Connected' and your PC will be connected to the internet.



You must run ActiveSync 4.2 or later in order to use this feature. If you are running an earlier version, upgrade to this using the companion CD that came with your device.

If you have chosen to connect using Bluetooth PAN

1. You will be prompted if you wish to make your device visible to other users. Click 'Yes' if this is the first time that you are setting up the connection
2. On your PC, perform a Bluetooth Search for the Pocket PC
3. Follow the process shown on your PC screen to bond it to the Pocket PC

4. On your PC, go to Start > Connect to > Show All connections
5. Double click the Icon in the Bluetooth Personal Area Network area
6. Choose to connect the PC to the Pocket PC
7. Your PC will now be connected to the internet.

As stated above, full instructions for performing this procedure on a Windows XP PC running the standard Microsoft Bluetooth stack can be found at <http://www.clubimate.com>, or on the Companion CD that came with your device.

7.15 Using Terminal Services Client

The Terminal Services Client allows you to log on to a PC running Terminal Services or Remote Desktop, and use all the resources available on that PC. For example, instead of running Word Mobile on your device, you can run the PC version of Word and access the .doc files available on that PC.

Connect to a Terminal Server

1. On your device, tap Start > Programs > Terminal Services Client.
2. Enter the server name.
3. You can also select a server name in Recent servers if you have recently connected to a server.
4. Select the Limit size of server desktop to fit on this screen check box if you want to use programs that have been specifically sized for use with your device.
5. Tap Connect.

Navigate within Terminal Services Client

When connected to a remote server, you may notice that your device screen is displaying more than one horizontal and vertical scroll bar. Use these scroll bars to either scroll the contents on the PC, or to scroll the PC display through the Terminal Services Client window.

To make sure you are scrolling the PC display through Terminal Services

Client, use the five directional buttons at the bottom of the Terminal Services Client window. To better fit information on your device screen, select the Limit size of server desktop to fit on this screen check box. For best results, the programs on your desktop PC should be maximized.

Disconnect without ending a session

1. From the Terminal Services Client screen on your device, tap Start > Shutdown.
2. Tap Disconnect.



Do not use the Start menu on your device. If a network administrator has configured Terminal Services Client on your device to reconnect to disconnected sessions, and you previously disconnected from a Terminal Server without ending the session, the Terminal Services Client reconnects to that session.

Disconnect after ending a session

1. From the Terminal Services Client screen on your device, tap Start > Shutdown.
2. Tap Log Off.

7.16 File Explorer

Your Pocket PC has a File Explorer application, just like your PC, that allows you to manage files.

To Run File Explorer

From the Today Screen go to Start > Programs > File Explorer. You are presented with a list of files and folders for the current folder. To move up a level, tap Up. To go into a folder, click on a folder name.

To copy a file

1. Tap and hold on a file name. A menu will appear.
2. Choose Copy

3. Now move to another folder. When you reach the folder where you want the file, press and hold on the screen with the stylus and press 'Paste'



to move the file rather than copy it, select 'Cut' in step 2.

To email a file

1. Tap and hold on the name of a file
2. Select the 'Send...' option from the menu that appears
3. Choose an account from which you will send this file.
4. Enter an addressee for the file, and press Send when ready to send. The file will be sent as an attachment.

To Delete a file

1. Tap and hold on the name of a file
2. From the Menu, select Delete

To create a new folder on the device

1. Move to the directory where you want to create a new directory.
2. Press Menu > New Folder

To View a Web Folder from your device

You can access folders on your company intranet.

To do this press Menu > Open Path and type in the path of the folder on the network.

Your device will connect to the Work Connection in order to find the web folder.

7.17 Adding more programs to your device

You can add more programs to your device, by purchasing on the internet or at a local retailer. Programs may be added using ActiveSync, or by installing the memory card that may come with your new purchase.

Chapter 8.

Maintaining your phone

- 8.1 Maintaining your phone
- 8.2 Resetting your Phone
- 8.3 Installing your SIM card
- 8.4 Managing Programs Memory

8.1 Maintaining your phone

Your phone is a well-designed and engineered product and the following tips and suggestions will enable you to obtain the best use of your phone for many years.

- Keep the phone in a dry environment. If the phone or battery were to get wet due to misuse, this can invalidate the manufacturer's warranty.
- Do not use the phone with wet hands to avoid any shocks and risks of water entering into the device, thereby increasing the risk of damage to internal circuits. This applies also if you have to replace the SIM or micro SD card inside the phone for whatever reason.
- Keep the phone and its accessories out of reach of young children and pets. They may accidentally damage the phone or risk swallowing the smaller components.
- Avoid storing the phone in hot environments as high temperatures can shorten the life of electronic components. There is the risk that the plastic casing can warp or melt if the temperature is high enough.
- Also please avoid storing the phone in cold environments. When the phone is switched on and warms up to its normal operating temperature, moisture can form inside the devices which may damage the circuit boards internally.
- Avoid dropping or any hard knocks to the phone as these shocks can damage the internal circuit boards.
- If you need to clean the phone, wipe it with a soft clean cloth – avoid use of cleaning solvents or detergents. DO NOT use water to clean the LCD screen.
- Do not attempt to respray or paint the phone.
- Do not keep the phone in or near heat sources such as a radiator or microwave oven – this can cause the battery inside the phone to overheat and explode.
- Ensure that the volume is turned down if you are using headphones.
- If the phone does not work, carry out some basic troubleshooting

checks and try the reset procedures described in the following section. If the problem persists, please do not attempt to service or repair the device yourself as this may invalidate the terms of the warranty with the device provider. The repair should be carried out by an authorized service provider.

8.2 Resetting Your Pocket PC Phone

Occasionally you may need to reset your Pocket PC Phone. A normal (or soft) reset of your device clears all active program memory and shuts down all active programs. This can be useful when the device is running slower than normal, or a program is not performing properly. A soft reset is also necessary after the installation of some programs. If a soft reset is performed when programs are running, unsaved work will be lost.

You can also perform a hard reset (also known as a full reset). A hard reset should be performed only if a normal reset does not solve a system problem. After a hard reset, the device is restored to its default settings — the way it was when you first purchased it and turned it on. Any programs you installed, data you entered, and settings you customized on the device will be lost. Only Windows Mobile software and other pre-installed programs will remain.

To perform a soft reset

Remove the battery cover and using the stylus, press on the small button to the left of the battery. Otherwise simply remove the battery, wait a few seconds and then insert the battery again.

To perform a Hard Reset

Hard reset by pressing device buttons:

1. Tap Start > Settings > System tab > Master Clear
2. On the System tab, select the Master Clear (!) icon
3. Proceed to enter the confirmation code: 1234 and push reset button, system will auto reboot to complete the operation.

8.3 Installing your SIM card

Follow these steps to install the GSM SIM (Subscriber Identity Module) card provided by your local network service provider. The SIM card contains your phone number, service details, and phonebook/message memory.

Your device supports both 1.8V and 3V SIM cards. Some legacy SIM cards will not function within this device. The customer should consult with their service provider for a replacement SIM card. There might be a fee for this service.

1. Make sure your device is turned off.
2. Slide the cover latch to remove the battery cover.

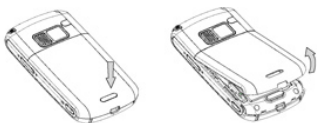

3. Proceed to remove the battery first. Then, insert the SIM card into the SIM card slot with its gold contacts facing down (the cut-off corner of the SIM card should match the cut-off corner in the slot).

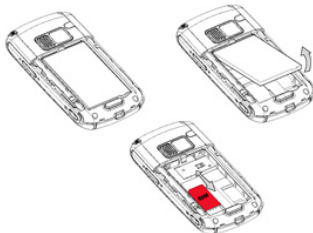

4. Replace the battery and gently push down to snap it into place.
5. Replace the battery cover.

8.4 Managing Programs Memory

You may need to stop a program if the program memory is low or if the application stops responding.

To see how much memory is available

- Tap Start > Settings > System tab > Memory.
- On the Main tab, the amount of memory allocated to file and data storage versus program storage is displayed, as well as the amount of memory in use versus the available memory.

Storage	Program
Total: 68.50 MB	Total: 43.47 MB
In use: 52.65 MB	In use: 24.54 MB
Free: 15.86 MB	Free: 18.93 MB

Main	Storage Card	Running Programs
	Find large files using storage memory.	

Storage and Program Memory

To see available storage card memory

You can see how much memory is available on a storage card that is inserted in your device.

1. Tap Start > Settings > System tab > Memory.
2. Tap the Storage Card tab.

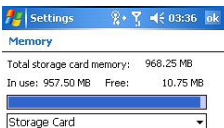

Storage Card Space

To free up memory

Try the following to free memory on your device:

- Close programs you are not currently using.
- Move e-mail attachments to a storage card.
- Move files to a storage card. Tap Start > Programs > File Explorer. Tap and hold the file, and tap Cut. Browse to the storage card folder and tap Edit > Paste.
- Delete unnecessary files. Tap Start > Programs > File Explorer. Tap and hold the file, and tap Delete.
- Delete large files. To find your largest files, tap Start > Programs > Search. In the Type list, tap Larger than 64 KB, and tap Search.
- In Internet Explorer Mobile, delete temporary Internet files and clear history information. For more information, see "Internet Explorer Mobile" in Chapter 7.
- Remove programs you no longer use.
- Reset your device.

Appendix

Other Applications

A.1 Battery Information

A.2 PC Requirement to Run ActiveSync 4.2

A.3 Regulatory Notices

A.4 Screen Resolution

A.1 Battery Information

Battery performance depends on many factors, including your wireless service provider's network configuration, signal strength, the temperature of the environment in which you operate your phone, the features and/or settings you select and use, items attached to your device's connecting ports, and your voice, data, and other program usage patterns.

Battery life estimates (approximations):

- Talk time: 4 hours
- Standby time: 150 hours

To check the battery power

- On the Today screen, Tap Start > Settings > System Tab > Power.
- On the Today screen, Tap the battery icon 

To optimize the power performance

- Tap Start > Settings > System > Power, and adjust the automatic turn-off feature

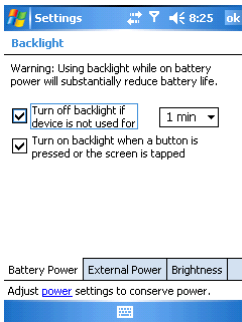

- Tap Start > Settings > System > Power, and adjust the automatic turn-off feature

To manage a low battery

1. Immediately save your current data.
2. Synchronize with your PC to charge the battery.
3. Turn off your phone.

For information about charging the battery, see the Quick Start Guide.

 **Warning! DANGER OF EXPLOSION IF BATTERY IS INCORRECTLY REPLACED. TO REDUCE RISK OF FIRE OR BURNS, DO NOT DISASSEMBLE, CRUSH, PUNCTURE, SHORT EXTERNAL CONTACTS, EXPOSE TO TEMPERATURE ABOVE 60°C (140°F), OR DISPOSE OF IN FIRE OR WATER. REPLACE ONLY WITH SPECIFIED BATTERIES. RECYCLE OR DISPOSE OF USED BATTERIES ACCORDING TO THE LOCAL REGULATIONS OR REFERENCE GUIDE SUPPLIED WITH YOUR PRODUCT.**



A.2 PC requirements to run ActiveSync 4.2

At the time of writing this manual, the requirements for this were published from Microsoft's website for ActiveSync 4.2 – <http://www.microsoft.com/windowsmobile/downloads/as-sysreq42.msp>

Supported Operating Systems

- Microsoft Windows 2000 Service Pack 4;
- Windows Server 2003 Service Pack 1;
- Windows Server 2003 Service Pack 1 for Itanium powered Systems;
- Windows Server 2003, Datacenter Edition

for 64-Bit Itanium-Based Systems;

- Windows XP Professional 64-Bit Edition (Itanium);
- Windows XP Service Pack 1;
- Windows XP Service Pack 2;
- Windows XP Tablet PC Edition;
- Microsoft Windows XP Media Center Edition;
- Microsoft Outlook 2000, Microsoft Outlook XP, or Microsoft Outlook 2003 messaging and collaboration clients required for synchronization to the desktop or portable computer of e-mail, Calendar, Contacts, Tasks, and Notes. (Outlook 2003 is recommended)
- Microsoft Office 2000, Microsoft Office XP or Microsoft Office 2003
- Microsoft Internet Explorer 6.0 or later (required)
- Microsoft Systems Management Server 2.0

The following mobile device operating systems are supported by ActiveSync 4.2

- Microsoft Windows Mobile 5.0
- Messaging and Security Feature Pack for Microsoft Windows Mobile 5.0
- Microsoft Windows Mobile 2003 Second Edition
- Microsoft Windows Mobile 2003
- Microsoft Pocket PC 2002, Microsoft Windows CE OS version 3.0
- Microsoft Smartphone 2002, Microsoft Windows CE OS version 3.0

A.3 Regulatory Notices

Agency identification numbers

For regulatory identification purposes, your product (i-mate™ PDAL) is assigned a model number of Pean.

To ensure continued reliable and safe operation of your Smartphone, use only the accessories listed in this document.

This product is intended to be used with a certified class 2 limited power source, rated 5.6 volts DC, maximum 750mA power supply unit.

European Union Notice

Products with CE marking comply with the R&TTE Directive (995//EC), the EMC Directive (89336//EEC) and the Low Voltage Directive (7323//EEC) issued by the Commission of the European Community.

Compliance with these directives implies conformity to the following European Norms:

- EN 60950 -1 (IEC 60950) – Safety of Information Technology Equipment.
- ETSI EN 301 511 V9.0.2(200303-) for Mobile communications (GSM); Harmonized standard for mobile stations in the GSM 900 and DCS 1800 bands covering essential requirements under article 3.2 of the R&TTE directive (19995//EC)
- ETSI TS 151 010 – 1 V7.0.1(200602-) Digital cellular telecommunications system(Phase 2+) Mobile Station (MS) conformance specification; Part 1 : Conformance specifications
- EN 50360 - 2001 – Product standard to demonstrate the compliance of mobile phones with the basic restrictions related to human exposure to electromagnetic fields (300 MHz ~ 3 GHz).
- EN 50361 - 2001 – Basic standard to demonstrate the compliance of mobile phones with the basic restrictions related to human exposure to electromagnetic fields (300 MHz ~ 3 GHz).
- SAR value 0.805mW/g @10g (CE).
- ETSI EN 301 4891- Electromagnetic compatibility and Radio spectrum Matters (ERM); ElectroMagnetic Compatibility (EMC) standard for radio equipment and services; Part 1: Common technical requirements.
- ETSI EN 301 4897- – Electromagnetic compatibility and Radio spectrum Matters (ERM); ElectroMagnetic Compatibility (EMC) for radio equipment and services; Part 7: Specific conditions for mobile and portable radio and ancillary equipment of digital cellular radio telecommunications systems (GSM and DCS).
- ETSI EN 301 48917- Electromagnetic compatibility and Radio spectrum Matters (ERM); ElectroMagnetic Compatibility (EMC) standard for radio equipment and services; Part 17: Specific conditions for 2.4 GHz wideband transmission systems.

- ETSI EN 300 328 Electromagnetic compatibility and Radio spectrum Matters (ERM); Wideband Transmission systems; data transmission equipment operating in the 2.4 GHz ISM band and using spread spectrum modulation techniques.



Important Health and Safety Information

Retain and follow all product safety and operating instructions. Observe all warnings on the product and in the operating instructions. To reduce the risk of bodily injury, electric shock, fire and damage to the equipment, observe the following precautions.

General Precautions

Safety precautions for RF exposure

Use only original manufacturer-approved accessories, or accessories that do not contain any metal.

Use of non-original manufacturer-approved accessories may violate your local RF exposure guidelines and should be avoided.

Safety Precautions

- **SAFETY IN AIRCRAFT:** This product can cause interference to an aircraft's navigation system and network. In most countries it is against the law to use this product on board an airplane.
- **ENVIRONMENTAL SAFETY:** Do not use this product in gas stations, fuel stores, chemical plants and locations containing explosives.
- **ROAD SAFETY:** Vehicle drivers in motion are not permitted to use handheld telephony services, except in emergency. In some countries, using hands-free devices as an alternative is allowed.
- **MEDICAL EQUIPMENT SAFETY:** This product may cause medical equipment malfunction. In most hospitals or medical centers use of this product is forbidden.

Heed service markings

Except as explained elsewhere in the Operating or Service documentation, do not service any product yourself. Service needed on components inside these compartments should be done by an authorized service technician or provider.

Damage requiring service

Unplug the product from the electrical outlet and refer servicing to an authorized service technician or provider under the following conditions:

- Liquid has been spilled or an object has fallen into the product.
- The product has been exposed to rain or water.
- The product has been dropped or damaged.
- There are noticeable signs of overheating.
- The product does not operate normally when you follow the operating instructions.

Avoid hot areas

The product should be placed away from heat sources such as radiators, heat registers, stoves, or other products (including amplifiers) that produce heat.

Avoid wet areas

Never use the product in a wet location.

Avoid pushing objects into product

Never push objects of any kind into cabinet slots or other openings in the product.

Use product with approved equipment

This product should be used only with personal computer and options identified as suitable for use with your equipment.

Cleaning

Unplug the product from the wall outlet before cleaning. Do not use liquid cleaners or aerosol cleaners. Use a damp cloth for cleaning, but NEVER use water to clean the LCD screen.

SAR Information

SAR value: 0.805W/Kg @10g (CE); 0.491W/Kg @1g (FCC) head;
0.724W/Kg @ 1g (FCC) body.

Use of non i-mate approved accessories may violate FCC RF exposure guidelines and should be avoided.

WEEE Notice



The Directive on Waste Electrical and Electronic Equipment (WEEE), which entered into force as European law on 13th February 2003, resulted in a major change in the treatment of electrical equipment at end-of-life.

The purpose of this Directive is, as a first priority, the prevention of WEEE, and in addition, to promote the reuse, recycling and other forms of recovery of such wastes so as to reduce disposal.

The WEEE logo (shown on the top) on the product or on its box indicates that this product must not be disposed of or dumped with your other household waste. You are liable to dispose of all your electronic or electrical waste equipment by relocating over to the specified collection point of recycling of such hazardous waste. Isolated collection and proper recovery of your electronic and electrical wastes equipment at the time of disposal will allow us to help conserving natural resources. Moreover, proper recycling of the electronic and electrical waste equipment will ensure safety of human health and environment. For more information about electronic and electrical waste equipment disposal, recovery, and collection points, please contact your local city centre, household waste disposal service, shop from where you purchased the equipment, or manufacturer of the equipment.

RoHS Compliance

This product is in compliance with Directive 2002/95/EC of the European Parliament and of the Council of 27 January 2003, on the restriction of the use of certain hazardous substances in electrical and electronic equipment (RoHS) and its amendments.

A.4 Specifications

System Information

Processor	TI OMAP 850
Memory	- ROM : 128 MB - RAM : 64 MB
Operating System	Windows Mobile™ Version 5.0

Display

LCD Type	2.5" transfective TFT-LCD with back-light LEDs, touch-sensitive screen
Resolution	240 x 320 with 65,536k colors
Alignment Support	Landscape and Portrait

GSM/EDGE Module

Functionality	GSM/EDGE (850, 900, 1800, and 1900)
Mode	GPRS class 10
Internal Antenna	Yes

Camera Module

Type	2 Mega pixel with fixed lens and digital Zoom
Resolution	1600x1280, 1280x1024 (SXGA), 640x480 (VGA), 320x240 (QVGA), 160x120 (QQVGA), 352x288 (CIF), 176x144 (QCIF)

Physical

Dimensions	112mm(L) x 56mm(W) x 17mm(T)
Weight	116g (with battery)

Controls and Lights

Navigation Buttons	<ul style="list-style-type: none"> - 5-way Navigation pad - Two customizable program buttons : Camera, Messaging - Two phone functions : Call and End - Start and OK keys - Two Soft Keys - Scroll wheel with Action Function and additional OK key - Power On/Off button - Reset button (need to remove battery cover to access it)
LEDs	Bi-color LED: Green and Red for GSM standby, SMS message, GSM network status, notification, battery charging status.

Audio

Microphone/Speaker	Built-in/Dual, Hands-free
Codecs	MIDI, MP3, WMA, WAV, AMR

Connections

I/O port	Mini USB 1.1
Bluetooth	<ul style="list-style-type: none">• Bluetooth- V 1.2 Class- 2 transmit power- Supported profiles<ul style="list-style-type: none">› Generic Access profile› Serial Port profile› Headset profile› Object Push profile› DUN (dial-up networking profile)› Hands-free profile› Generic Object Exchange profile› A2DP (Advanced Audio Distribution profile)› AVRCP (Audio/Video Remote control Profile)› HID (Human interface device profile)› SAP› BIP› ActiveSync Profile
WiFi	802.11b/g
Antenna	Internal connector for GSM and EDGE

Audio	Stereo earphone/microphone jack
-------	---------------------------------

Expansion Slots

microSD Card	Yes
--------------	-----