

SHARP®

NOTEBOOK COMPUTER

PC-TN1 Series

OPERATION MANUAL

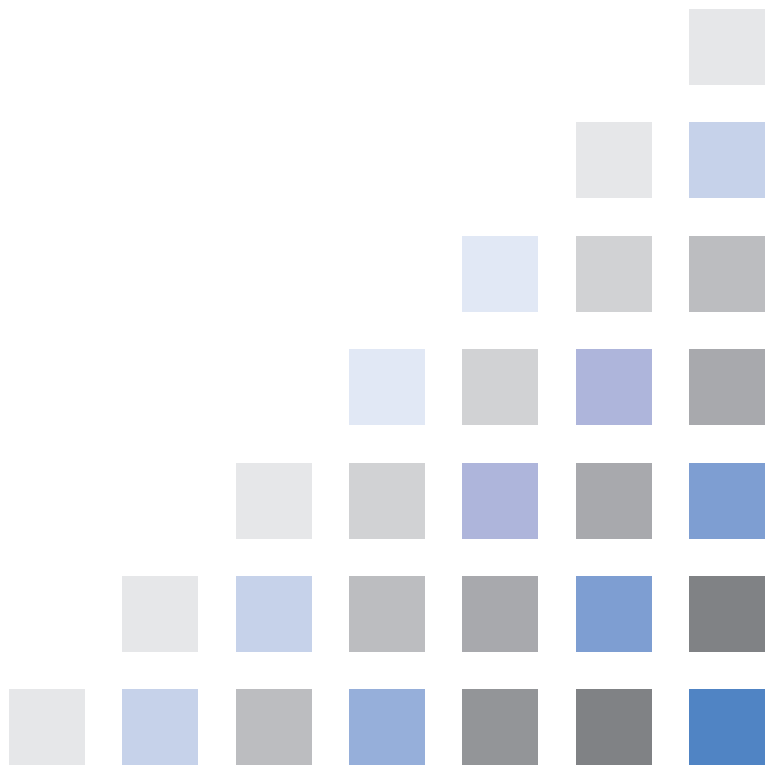

Notice for Users in the USA

FCC Statement

WARNING - FCC Regulations state that any unauthorized changes or modifications to this equipment not expressly approved by the manufacturer could void the user's authority to operate this equipment.

Note: This equipment has been tested and found to comply with the limits for a Class B digital device pursuant to Part 15 of the FCC Rules.

These limits are designed to provide reasonable protection against harmful interference in a residential installation. This equipment generates, uses and can radiate radio frequency energy and, if not installed and used in accordance with the instructions, may cause harmful interference to radio communications. However, there is no guarantee that interference will not occur in a particular installation. If this equipment does cause harmful interference to radio or television reception, which can be determined by turning the equipments off and on, the user is encouraged to try to correct the interference by one or more of the following measures:

- Reorient or relocate the receiving antenna.
- Increase the distance between the equipment and receiver.
- Connect the equipment into an outlet on a circuit different from that to which the receiver is connected.
- Consult the dealer or an experienced radio/TV technician for help.

A shielded I/F cable is required to insure compliance with FCC regulation for Class B computing equipment.

* As an ENERGY STAR[®] Partner, SHARP has determined that this product meets the ENERGY STAR[®] guidelines for energy efficiency.

Declaration of Conformity

SHARP PERSONAL COMPUTER, PC-TN Series.

This device complies with part 15 of the FCC rules. Operation is subject to the following conditions:(1) this device may not cause harmful interference, and (2) this device must accept any interference received, including interference that may cause undesired operation.

Responsible Party: SHARP ELECTRONICS CORPORATION
Sharp Plaza, Mahwah, New Jersey 07430-2135
TEL: 1-800-BE-SHARP

FCC Radiation Exposure Statement

The available scientific evidence does not show that any health problems are associated with using low power wireless devices. There is no proof, however, that these low power wireless devices are absolutely safe. Low power Wireless devices emit low levels of radio frequency energy (RF) in the microwave range while being used.

Whereas high levels of RF can produce health effects (by heating tissue), exposure to low level RF that does not produce heating effects causes no known adverse health effects. Some studies have suggested that some biological effects might occur, but such findings have not been confirmed by additional research. PC-TN10W has been tested and found to comply with the Federal Communications Commission (FCC) guidelines on radio frequency energy (RF) exposure. The maximum SAR levels tested for the PC-TN10W has been shown to be 0.560W/kg at Body.

About the Modem

This equipment complies with Part 68 of FCC rules. On the bottom of this equipment is a label that contains, among other information, the FCC registration number and ringer equivalence number (REN) for this equipment. If requested, this information must be provided to the telephone company.

The modem jack of this equipment complies with Sub-part F of Part 68 of FCC rules.

The REN is used to determine the quantity of devices which may be connected to the telephone line. Excessive RENs on the telephone line may result in the devices not ringing in response to an incoming call. In most, but not all areas, the sum of the RENs should not exceed five (5.0). To be certain of the number of devices that may be connected to the line, as determined by the total RENs contact the telephone company to determine the maximum REN for the calling areas.

If the terminal equipment causes harm to the telephone network, the telephone company will notify you in advance that temporary discontinuance of service may be required. But if advance notice isn't practical, the telephone company will notify the customer as soon as possible. Also, you will be advised of your right to file a complaint with the FCC if you believe it necessary.

The telephone company may make changes in its facilities, equipment, operations, or procedures that could affect the operation of the equipment. If this happens, the telephone company will provide advance notice in order for you to make the necessary modifications in order to maintain uninterrupted service.

If trouble is experienced with this equipment, please contact Sharp Electronics Corp. for repair and (or) warranty information (refer to the provided Consumer Limited

Warranty sheet). If the trouble is causing harm to the telephone network, the telephone company may request you remove the equipment from the network until the problem is resolved.

The equipment cannot be used on public coin service provided by the telephone company. Connection to Party Line Service is subject to state tariffs. (Contact the state public utility commission, public service commission or corporation commission for information.)

The Telephone Consumer Protection Act of 1991 makes it unlawful for any person to use a computer or other electronic device, including fax machines, to send any message unless such message clearly contains in a margin at the top or bottom of each transmitted page or on the first page of the transmission, the date and time it is sent and an identification of the business or other entity, or other individual sending the message and the telephone number of the sending machine or such business, other entity, or individual. (The telephone number provided may not be a 900 number or any other number for which charges exceed local or long-distance transmission charges.) To program this information, refer to the manual of the communication software.

Warning

This product utilizes tin-lead solder, and fluorescent lamp containing a small amount of mercury.

Disposal of these materials may be regulated due to environmental considerations. For disposal or recycling information, please contact your local authorities or the Electronics Industries Alliance: www.eiae.org

Copyright

It is the intent of Sharp that this product be used in full compliance with the copyright laws of the United States and that prior permission be obtained from copyright owners whenever necessary.

Product Information and Customer Assistance

For Product Information and Customer Assistance:

Call: 1-800-BE-SHARP (237-4277)

Sharp Systems of America

5901 Bolsa Avenue, Huntington Beach, CA 92647

Home Page: <http://www.sharpsystems.com>

E-mail address: ssa-support@sharpsystems.com

CAUTION:

TO PREVENT ELECTRICAL SHOCK, DISCONNECT THE AC CORD AND THE BATTERY BEFORE SERVICING.

CAUTION:

FOR A COMPLETE ELECTRICAL DISCONNECTION, PULL OUT THE MAINS PLUG AND THE BATTERY.

VORSICHT:

UM DIE STROMZUFUHR VOLLSTÄNDIG ZU UNTERBRECHEN, DEN NETZSTECKER HERAUSZIEHEN UND DIE BATTERIE ENTFERNEN.

ATTENTION:

POUR UN ARRÊT TOTAL DU SYSTÈME, DECONNECTEZ LA PRISE DE COURANT SECTEUR ET LA BATTERIE.

VARNING:

FÖR TOTAL ELEKTRISK URKOPPLING, KOPPLA UR KONTAKTEN OCH TA UR BATTERIET.

PRECAUCION:

PARA UNA COMPLETA DESCONEXION ELECTRICA DESENCHUFE LA CLAVIJA DE LA RED Y LA BATERIA.

Safety Precautions

General

- Follow all cautions and instructions, which may be marked, on your computer.
- Except as described elsewhere in this manual, refer all servicing to qualified personnel. Immediately shut off your computer and seek servicing under the following conditions:
 - when the power cord or plug is damaged or frayed
 - when liquid has been spilled on your computer
 - when your computer has been dropped or the cabinet has been damaged

Location

- Do not expose your computer to direct sunlight.
- Try to avoid dusty environments.
- Keep your computer away from any magnetic devices and TVs.
- Keep your computer away from excessive humidity or fluids such as rain, snow, water spray, juice, coffee, steam, etc.
- Do not move your computer from an extremely cold place to an extremely warm place. A temperature difference of more than 10°C (18°F) will cause condensation inside the unit, which may cause damage.
- Do not block or cover slots or openings on the cabinet. These protect your computer from overheating.
- Do not place your computer on an unstable or uneven work surface.
- Care must be taken for children not to swallow the tablet pen tip.
- Do not store your computer in tablet mode with the LCD side up.
- Care should be exercised when using on heat sensitive surfaces or your lap or in your arms, as the base of your computer will get hot.

Usage

- Never push any kind of objects into cabinet openings. They may touch dangerous voltage points or short parts that could result in fire or electrical shock.
- Turn off your computer before installing or removing peripheral devices except when connecting USB devices, an IEEE1394 device, a PC card, etc.

- Check the AC power cord and power connectors periodically for damage. Change the power cord immediately if damage is found.
- Be careful not to get burned by the heated air from the ventilation openings when using your computer on your lap or in your arms for extended period. If you feel uncomfortable, stop using it until it becomes cool.
- Do not exposure any part of your body to the palm rest or the bottom of your computer for extended period.
- Never subject your computer to sudden shocks or extreme vibration.
- Do not drop your computer nor hit it with other equipment.
- Do not scratch the surface of the LCD screen.
- Turn off your computer and disconnect the AC power cord before cleaning.

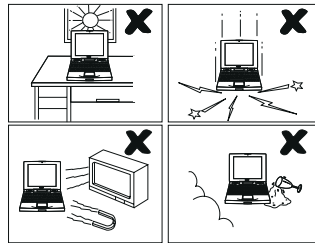

Battery Precautions

CAUTION

DANGER OF EXPLOSION IF BATTERY IS INCORRECTLY REPLACED. REPLACE ONLY WITH THE SAME OR EQUIVALENT TYPE RECOMMENDED BY THE MANUFACTURER. DISCARD USED BATTERIES ACCORDING TO THE MANUFACTURER'S INSTRUCTIONS.

Handling

- Never put the battery pack in a fire, as it could explode and cause injury.
- Do not attempt to open or alter the battery pack.
- Do not place the battery where it might get hotter than 60°C (140°F).
- The battery pack must be kept from metal objects such as jewelry and liquids. They might trigger a short circuit and consequently cause the battery pack to heat up and explode.

- Do not allow liquids to come in contact with the battery pack.
- Care must be taken not to drop the pack. A violent shock damages the pack.
- Do not solder anything to the battery terminals.

Charging

- Charge the battery pack only with the AC adapter and AC power cord included with your computer.

Discharging

- Do not use the battery pack for any purpose other than powering your computer.

Storage

- Store the battery pack in a cool and dry place. Never allow the temperature to exceed 60°C (140°F) during storage.
- Recharge the stored battery pack, before using it.

Modem Precautions

IMPORTANT SAFETY INSTRUCTIONS

When using your telephone equipment, basic safety precautions should always be followed to reduce the risk of fire, electric shock and injury to persons, including the followings:

- Do not use this product near water, for example, near a bath tub, wash bowl, kitchen sink or laundry tub, in a wet basement or near a swimming pool.
- Avoid using a telephone (other than a cordless type) during an electrical storm. There may be a remote risk of electric shock from lightning.
- Do not use the telephone to report a gas leak in the vicinity of the leak.
- Never install telephone wiring during a lightning storm.
- Never install telephone jacks in wet locations unless the jack is specifically designed for wet locations.
- Never touch uninsulated telephone wires or terminals unless the telephone line has been disconnected at the network interface.
- Use caution when installing or modifying telephone lines.

Wireless LAN Precautions

- Disable the integrated antennas and do not communicate with wireless LAN in specific environment where radio-susceptible equipment is nearby such as on airplanes, in hospitals, etc.

Other Precautions

- Your computer is integrated with a magnet on the left side of the display. Be sure to keep the magnetic cards or floppy disks away from the left side of your computer. Otherwise the data on the cards or floppy disks may be erased.

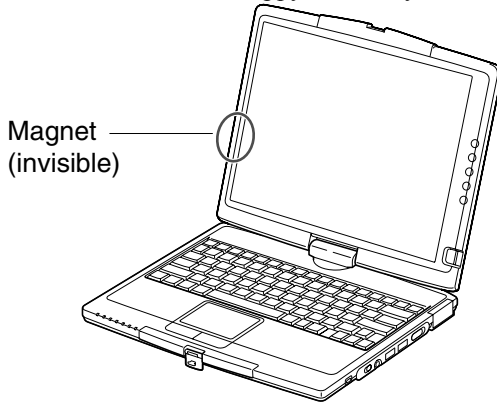

- Your computer also has a sensor on the left side of the keyboard which responds to the magnet. If you bring the magnet near the left side of the keyboard, the backlight may turn off, and the system may enter the standby or the hibernate mode depending on the setting. (See Chapter 4.)

About This Manual

Notice

Information in this manual is subject to change without notice and does not represent a commitment on the part of SHARP Corporation and its sales subsidiaries.

SHARP Corporation and its sales subsidiaries shall not be liable for technical or editorial errors or omissions contained herein; nor for incidental or consequential damages resulting from the furnishing, performance, or use of this material.

SHARP strongly recommends that separate permanent written records be kept of all important data. Data may be lost or altered in virtually any electronic memory product under certain circumstances. Therefore, SHARP assumes no responsibility for data lost or otherwise rendered unusable whether as a result of improper use, repairs, defects, battery replacement, use after the specified battery life has expired, or any other causes.

SHARP assumes no responsibility directly or indirectly, for financial losses or claims from third persons resulting from the use of this product and any of its functions, such as stolen credit card numbers, the loss of or alteration of stored data, etc.

Edition

1st Edition, October 2003.

Copyright

© 2003 SHARP Corporation

This document contains or refers to proprietary information which is protected by copyright. All rights are reserved. Copying or other reproduction of this document is prohibited without the prior written permission of SHARP Corporation.

Trademarks

Intel, Pentium, and Pentium M are trademarks or registered trademarks of Intel Corporation.

IBM is a trademark of International Business Machines Corporation.

Microsoft and Windows are registered trademarks of Microsoft Corporation in the United States and other countries. Windows Media is a trademark of Microsoft Corporation in the United States and other countries.

Compact Flash and CF are trademarks of SanDisk Corporation.

All other brand and product names are trademarks or registered trademarks of their respective holders.

Recording Important Information

For future reference, please record the following information in the spaces provided below.

Model Number:

Serial Number:

Date of purchase:

Dealer's Name:

Place of purchase:

Password:

The serial number is printed on a sticker located on the bottom of your computer.

Manual Conventions

This manual uses a set of style conventions described below.

Notes and Cautions are italicized with icons:



A note icon informs you of a special technique or information that may help you perform a task or better understand a process.



A caution icon alerts you to something that may cause problems or damage to hardware, software or data.

Key Labels on the Keyboard, when referred to in the instructions, are shown in boldface:

Press **Enter** to continue.

When two or more keys are pressed simultaneously, the key labels are separated by a plus (+) sign:

Restart your computer by pressing **Ctrl+Alt+Delete**.

Sample Entries are shown in lower cases of different typeface.

`c:\windows\systems`

Words/Texts on Screen, such as window titles or possible parameters, are italicized:

Double-click this icon to display the *Power Options Properties* dialog box.

Set the item to *Enabled*.

Screens reproduced in this manual may differ slightly from the screens you see on your computer.

Section Titles in other parts of this manual are italicized:

Refer to *Installing Battery Pack* section of Chapter 1.

Table of Contents

Notice for Users in the USA	i
Safety Precautions.....	v
About This Manual	ix
Recording Important Information	x
Manual Conventions	xi
Table of Contents.....	xii
Overview of Computer	xiv

Quick Setup

Installing Battery Pack.....	1-1
Turning On Your Computer.....	1-3
Setting Up Windows.....	1-5
Turning Off Your Computer.....	1-7

Basic Operations

Choosing Power Source.....	2-1
Resetting System.....	2-3
Using Glide Pad.....	2-4
Using Keyboard	2-6
Controlling Volume	2-7
Adjusting Display	2-8
Sharing Your Computer.....	2-10

Tablet Mode

Rotating Your Computer Display	3-1
Using Tablet Pen.....	3-5
Adjusting Screen Orientation.....	3-10
Using Programmable Button.....	3-12

Battery and Power Management

Battery Pack.....	4-1
Power Management	4-6

Peripherals

Peripheral Device Connectors.....	5-1
Optional External Floppy Disk Drive Unit.....	5-3
External Display	5-6
Audio System.....	5-8
USB Device	5-10
PC Card.....	5-11
Compact Flash Card.....	5-15
Printer	5-19
IEEE1394 Device	5-20

Communication Functions

Built-in Modem	6-1
LAN Unit.....	6-4
Wireless LAN	6-9
Network Setup Utility.....	6-13

Setup Utility

Running Setup Utility.....	7-1
Main Menu.....	7-3
Advanced Menu.....	7-4
Security Menu.....	7-4
Boot Menu	7-6
Exit Menu	7-7

Appendixes

Memory Module	A-1
Maintenance and Care	A-4
Re-installation Instructions.....	A-7

Troubleshooting

Index

Overview of Computer

Each number after an arrow indicates the page referring to the part. Actual appearance of your computer may be slightly different depending on the model.

Front

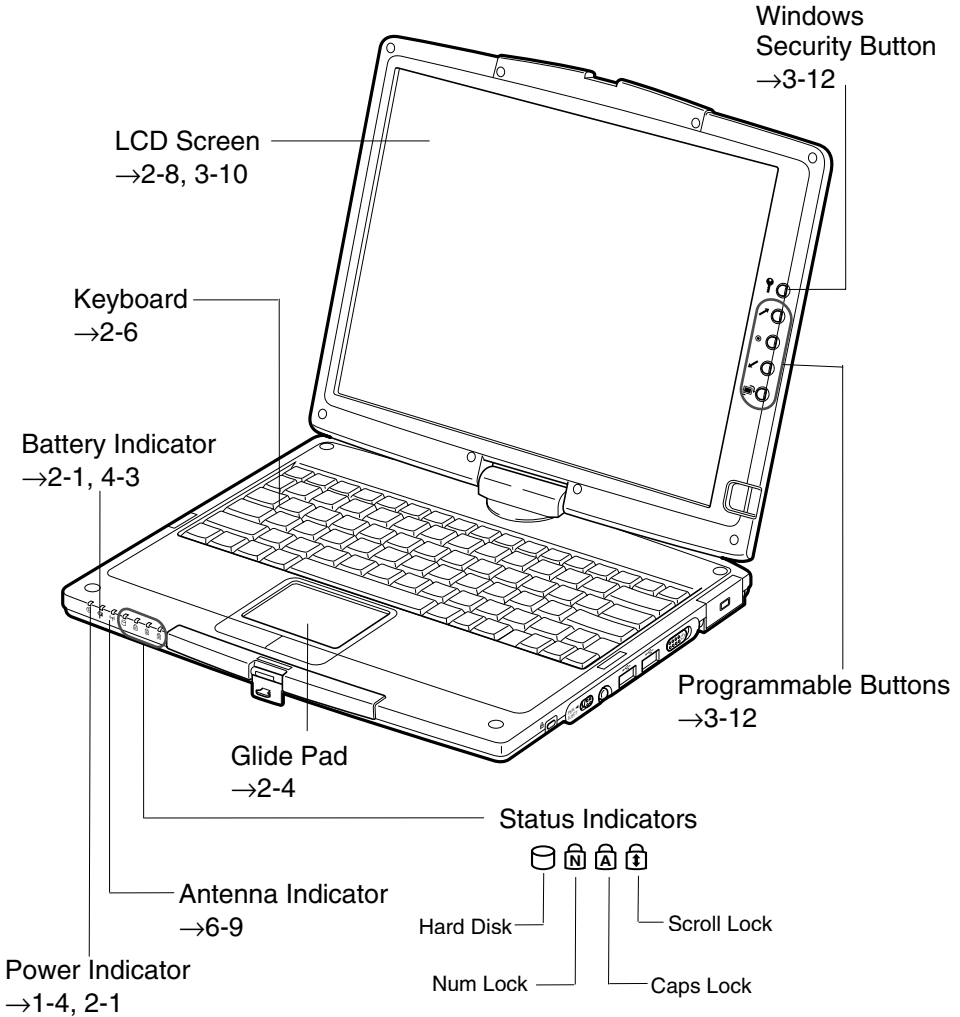

Right

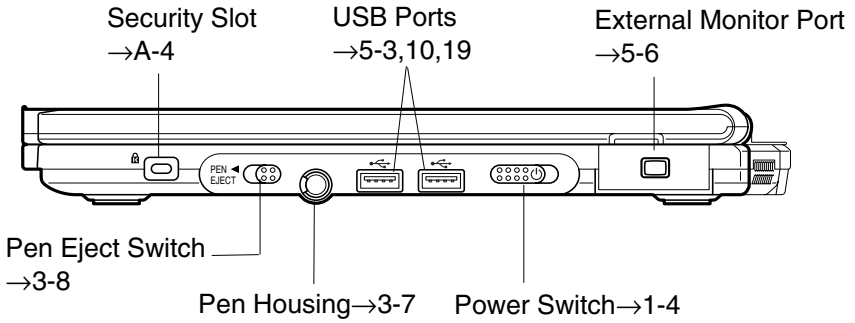

Left

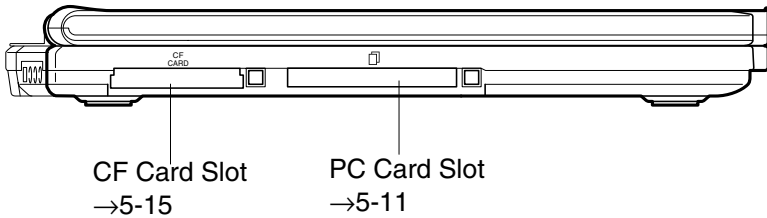

Back

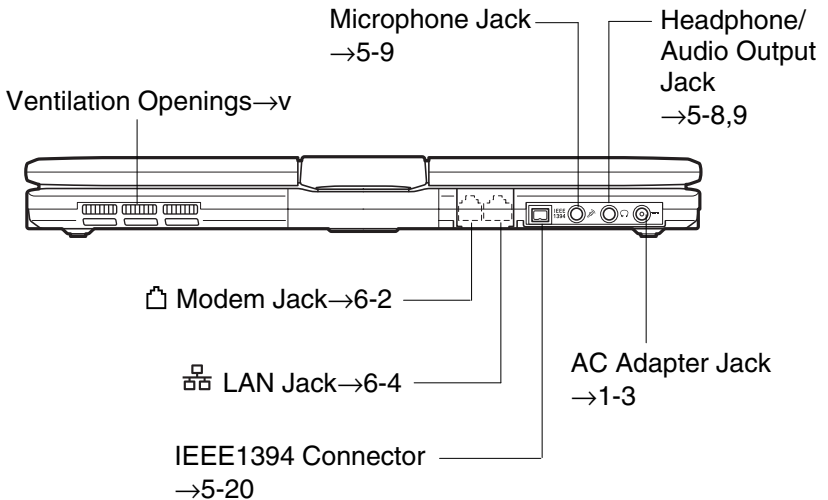

Bottom

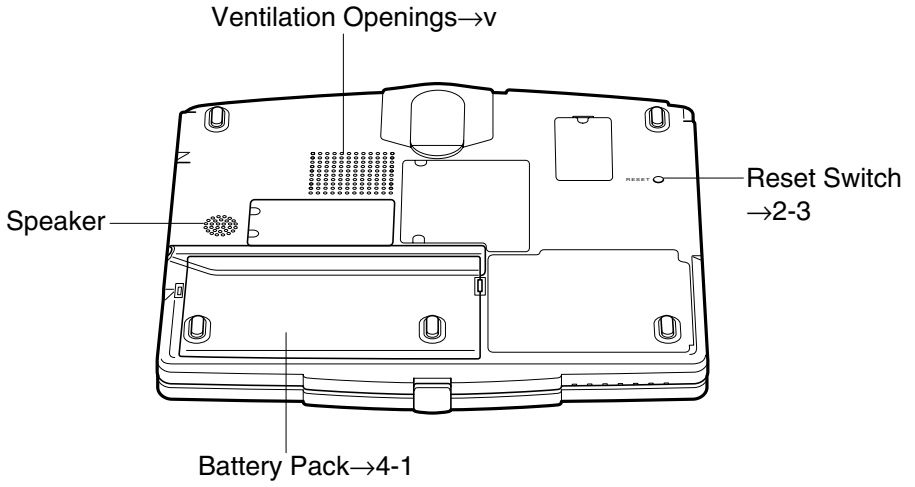

Quick Setup

Your computer is designed and pre-configured for easy setup and use. This chapter describes the steps to set up and run your computer as quickly as possible. Read this chapter first.

Installing Battery Pack

Your computer is powered with either the rechargeable battery pack or AC power source. See the next chapter for more information on the power sources. Before starting to use your computer for the first time, follow these instructions.

1. Place your computer with the bottom up on a stable work surface.

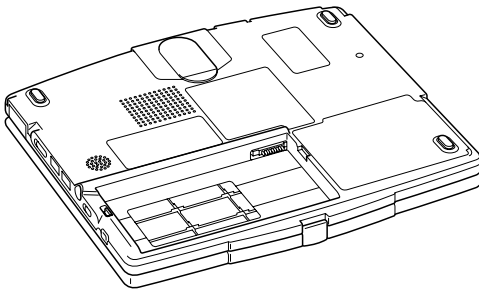

2. Insert the battery pack into the battery compartment by matching the projected parts of the battery with the notched parts on your computer.

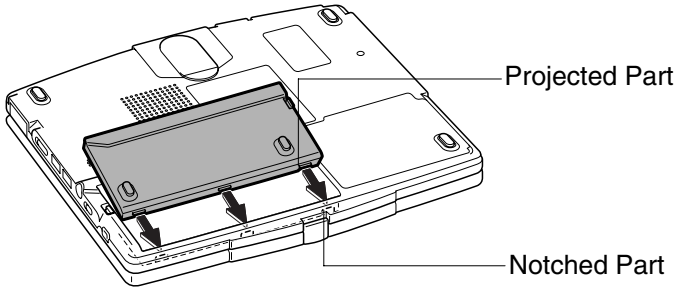

3. Push the battery pack until it is locked into the place.

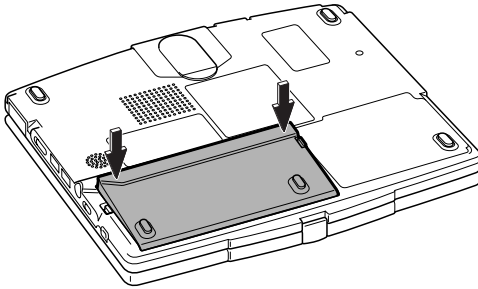

4. Turn your computer over and go to the next section.

Turning On Your Computer

Connecting to AC Power Source



- Always use the AC adapter and AC power cord included with your computer. Using others may damage your computer.
- Always hold the AC power cord by its plug when removing it from the wall outlet. Never pull on the cord.
- When using your computer for the first time, be sure to operate it on AC power. If on battery power instead, you may not be able to complete the Windows setup if the battery does not have enough power.

1. Plug the AC adapter cable to the AC adapter jack on your computer.



Do not insert into the headphone/audio jack or the microphone jack.

2. Plug the AC power cord into the AC adapter.
3. Plug the AC power cord into a wall outlet.

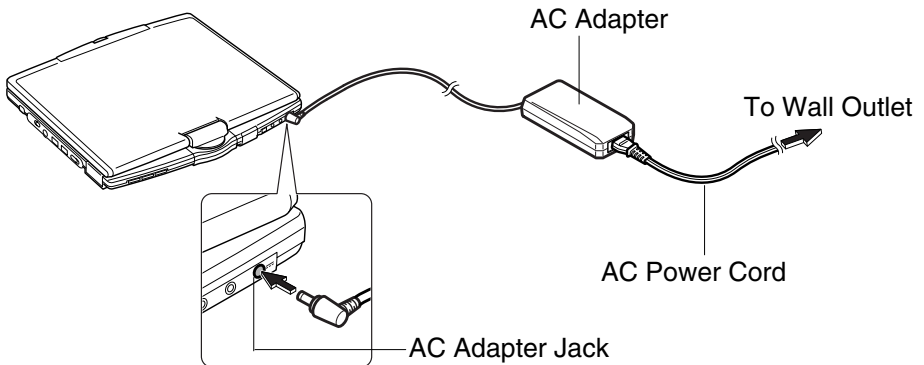

Opening Display

1. Unlock the display cover fastened with the hook and raise the cover. Set it in comfortable view position.

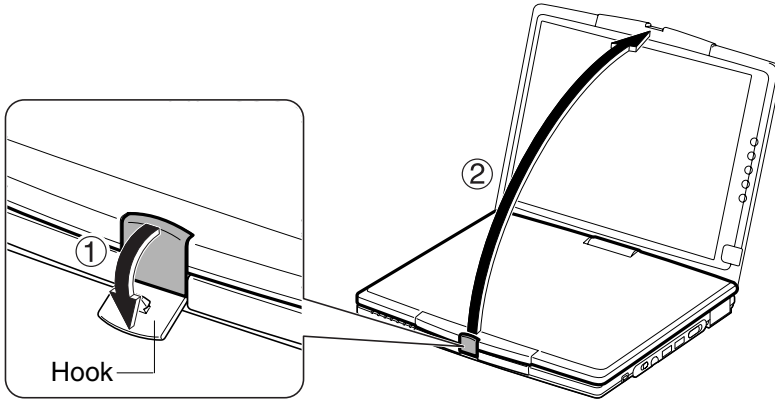

2. Slide the power switch, located on the right side of your computer, backward you to turn it on.

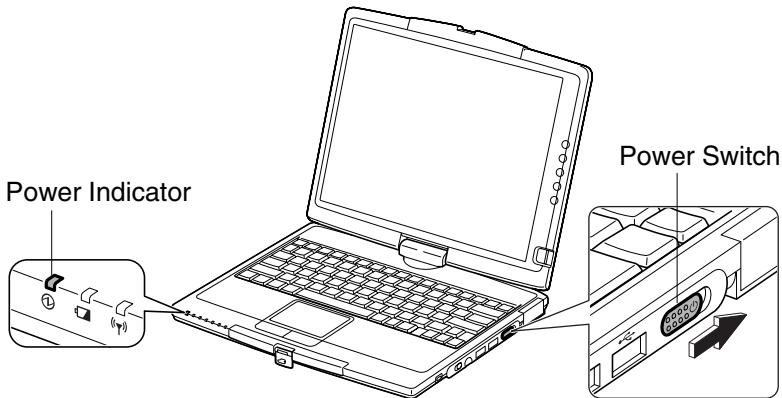

When you power on your computer, the power indicator (1) turns green, your computer goes through a self test to detect any problems, and Windows setup process starts. See the next section.

Setting Up Windows

To set up Windows, follow the instructions on the screen. See also the Windows quick start guide. It takes approximately 5-10 minutes to complete the entire setup process.



Use the keyboard and the glide pad for Windows setup. The tablet pen is not available for the setup.

The steps in the setup process are as follows:

- Configuring your location, language and keyboard type
- Configuring your time zone
- Accepting license agreement
- Naming your computer
- Setting the administrator's password
- Setting your network environment
- Creating an account
- Completing configuration



- *Do not turn off your computer until completing Windows setup. If you turn it off, you cannot set up Windows later.*
- *Be sure to connect your computer to AC power source. An undercharged battery may not be able to complete the Windows setup.*
- *Do not connect any peripheral devices to your computer until the Windows setup completes. Otherwise your computer may malfunction.*



- *If the display turns off, some power management may function. In this case, press any key to resume your computer from the power management. (Refer to Power Management section of Chapter 4.)*
- *If you cannot operate the keyboard or the touch pad, slide and hold the power switch for more than four seconds to turn off your computer. Be sure that the power indicator turns off; then, after more than 10 seconds, slide the power switch to turn it on back.*

After completing the Windows setup:

- Confirm *Time Zone* is correctly selected, and set date and time by double-clicking the time appearing on the right of the taskbar to open *Date and Time Properties* dialog box.
- When you want to activate the integrated antennas for wireless networking, press **Fn+F1** () keys.



- *When the setup is completed, Tablet PC Tutorials window will appear. If you want to exercise the tutorials, follow the on-screen instructions. Otherwise, close it by clicking the X button at the upper right corner of the window.*
- *When you skip the tutorials, you will have them next time you log on. If you don't need them, check the box of Do not show me this again appearing on the bottom of the window. You can display the tutorial window with the following steps if necessary.*
 1. *Click start – All Programs.*
 2. *Click Tablet PC – Tablet PC Tutorials.*

Properties Dialog Box in Windows

In this manual, you will often see the expression “XXX Properties dialog box.” The dialog box is a window containing text boxes, check boxes, buttons, etc., with which you can send commands to Windows or other applications. To open the properties dialog boxes, click *start - Control Panel*. The *Control Panel* has two types of views: *Category View* and *Classic View*. The *Category View* allows you to choose the category that may be related to what you want to do, then, choose your task by clicking it. The *Classic View* gives you the icons representing their components or features. Double-click one of the icons to open its dialog box or window. Some of the dialog boxes you will use often are:

- Display
- Phone and Modem Options
- Tablet and Pen Settings
- Power Options
- System



Clicking Switch to XXX View string appearing at the upper left of the Control Panel window allows you to toggle between the two views.

Turning Off Your Computer

When you've finished using your computer, turn it off with one of the following ways:

- From the *start* menu

1. Click *start – Turn Off Computer*.
2. In the *Turn off computer* dialog box, click *Turn Off*.

- With the power switch

Before using this step, confirm that *Shut down* is selected in *When I press the power button on my computer* in *Advanced* tab of *Power Options Properties* dialog box.



If you have not saved a file, a dialog box will appear asking whether you want to save it.



- *Do not turn off or reset your computer while the hard disk indicator or the indicator on the optional external floppy disk drive unit or the external optical drive unit is lit. Doing so may damage or even wipe out the data.*
 - *Before turning it on back, wait at least ten seconds after turning off your computer. Turning the power off and on in rapid succession can damage your computer's electrical circuitry.*
-

Closing Display

After turning off your computer, close the display cover ensuring that the LCD faces down and is aligned with the base cabinet and then, lock it with the hook.



Be sure that the display cover and the base cabinet are aligned vertically before locking it. Trying to lock forcibly with the LCD placed out of alignment will damage the hook.

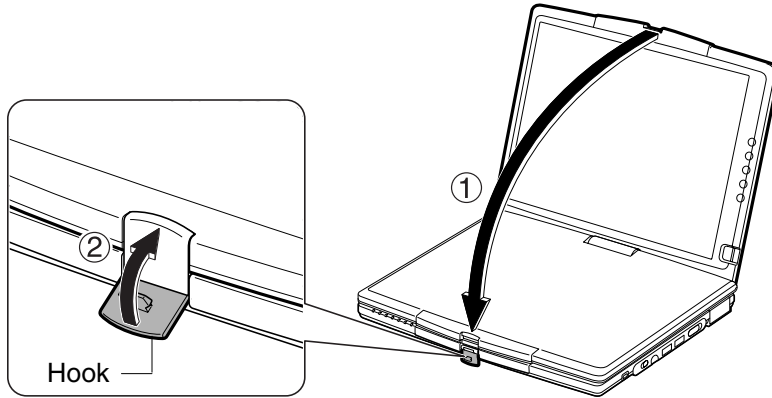

Basic Operations

This chapter describes the basic operations of your computer.

Choosing Power Source



2

You can use your computer with one of the following power sources:

- AC power from a wall outlet
Use AC power whenever possible; rely on the battery only when AC power is not available.
- Rechargeable battery
A rechargeable battery pack is supplied with your computer. See Chapter 4 for the battery information.

About Power Indicators

The following indicators show the power status of your computer.

Indicator	Light	Meaning	
Power 	On (green)	Operating	
	Blinking (green)	In System Standby	
	Off	Powered off or in System Hibernate	
Battery 	Connected to AC Power Source	On (green)	Fully charged
		On (orange)	Being charged
		Blinking (orange)	In abnormal state (Remove the battery pack and install it again.)
	Powered by Battery	Off	Has power
		Blinking (red)	Almost completely discharged (The warning beep sounds.)

The battery indicator is always off when your computer is turned off and not connected to AC power source.



- *When the battery is hot, the battery indicator may turn off and stay off until the battery becomes cool.*
- *For more information on System standby/hibernate, see Chapter 4.*

Using AC Adapter

When connected to a wall outlet, the AC adapter provides power for operation and charges the battery. The AC input voltage can range from 100 to 240 volts so that you can use your computer with the appropriate plug adapter.



The AC power cord included with your computer is appropriate for the voltage used in the area in which you purchased your computer. If you attempt to connect your computer to a wall outlet other than in this area, check the voltage of the outlet and use an AC power cord appropriate for the outlet. Consult local service staff if you are not sure.

Resetting System

You may need to restart the system if your computer becomes inoperable or after adding new hardware or software. When the message appears after the installation, click *OK*, *Yes*, etc. to restart Windows.



Resetting may cause data loss. Use the resetting process only if the normal Windows Shut Down does not work because of software malfunction. Although resetting will not damage the system, you may lose the data you are processing.

Warm Boot (Software Reset)

If the system is locked up because of a software problem, you can reset or reboot the system by pressing the **Ctrl+Alt+Del** keys simultaneously or the windows security button (Ⓜ) on the right side of the display, and select *Applications* tab of *Windows Task Manager* dialog box. Click the name of the program hanging up, then, *End Task*. If this does not work, select the current log-in user in *Users* tab and click *Disconnect* or *Logoff*, then, *Yes*.

Power Switch

You can turn off your computer with the power switch if you encounter hardware or software problems that lock up the system. In this case, slide and hold the switch for more than four seconds.

Reset Switch

If you cannot turn off your computer with the power switch, you can use the reset switch on the bottom of your computer. To reset the system, insert a narrow object into the small hole to press the switch.

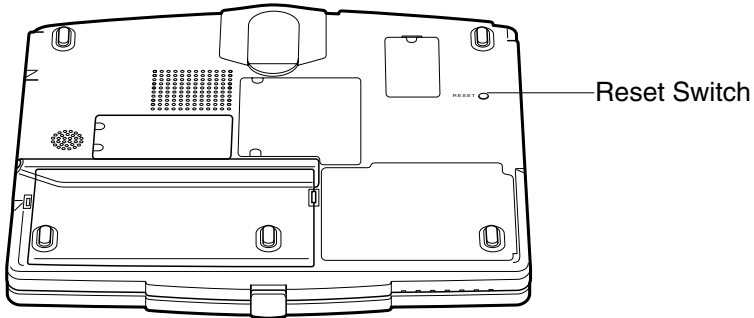

Using Glide Pad

Your computer is equipped with an integrated pointing device called a glide pad. Using the glide pad, you can move the pointer, select an item from a menu, and perform other tasks in the same way you would with a mouse.

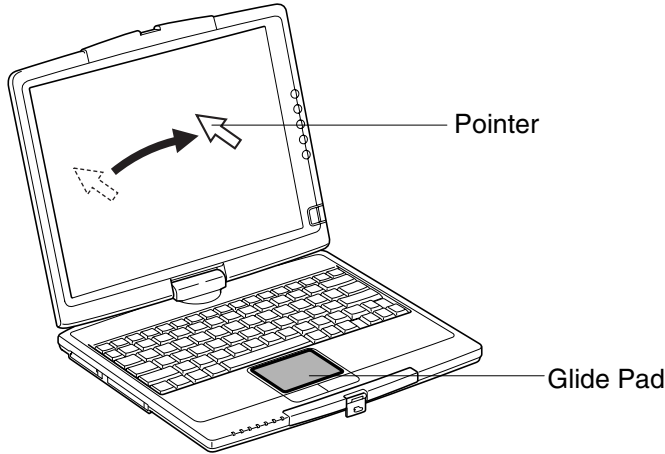

- *Do not hit or scratch the surface of the glide pad with pointed objects (such as a ballpoint pen, the provided tablet pen or others).*
- *Do not operate the glide pad with a moist finger. This may cause the glide pad to operate incorrectly.*

Using Glide Pad

Take a moment to become familiar with how the glide pad works.

Place Your Fingertip

Place your left or right hand next to the glide pad, resting your wrist naturally in a relaxed manner. Place your thumb or finger on the glide pad.

Move Your Fingertip

The rectangular pad of the glide pad acts like a miniature duplicate of the display. As you slide your fingertip across the pad in primary landscape mode, for instance, the pointer on the screen moves in the same direction across the screen. The glide pad is very sensitive, so you do not have to exert much pressure on the pad. The glide pad will respond to a light touch from your fingertip.

Click, Double-click, and Right-click

To click or double-click, you can use the left button just like that of a mouse. Instead of clicking or double-clicking the left button, you can also just tap gently or tap twice quickly anywhere on the rectangular pad. For right-clicking, you must use the right button.

Drag and Drop

You can move an item by using “drag and drop” below:

1. Position the pointer over the item.
2. Press the left button; do not release it.
3. Holding it down, move the pointer. The item moves together with the pointer.
4. Release the button when the item reaches its destination.

Or you can tap the pad twice and hold it instead of pressing the left button in the step 2.

Scroll

You can scroll through information in a list or in a document by using the glide pad. To view information vertically, place your finger on the most right part of the glide pad and slide your finger up and down. To view horizontally, place your finger on the bottom part of the glide pad and slide your finger to the left or the right. This procedure works only in limited applications.

Changing Configuration

In the *Mouse Properties* dialog box, you can change the configuration of the glide pad, such as swapping left and right buttons, changing the pointer size, etc. Double-click  icon on the taskbar.

Using Keyboard

Your computer, equipped with the Windows Enhanced Keyboard, provides all the functionality of a full-sized desktop keyboard.

Special Keys



Windows Key

Opens the Windows start menu.



Application Key

Opens an application-specific short-cut menu.
Equivalent to right-clicking.

System Function Keys

When pressed together with the **Fn** key, function keys set specific system parameters. This combination is sometimes referred to as “hot keys”.

Fn + F1 ()

Turns the wireless LAN antennas on and off

Fn + F5 ()

Rotates display mode between LCD only, an external monitor only, and both (when connecting an external monitor).

Fn + F6 ()

Decreases the LCD screen brightness.

Fn + F7 ()

Increases the LCD screen brightness.

Fn + F11 ()

Turns the LCD screen on and off.

Fn + F12 ()

Forces your computer into System standby. See *Power Management* of Chapter 4 for more information.



*Do not press the **Fn+F5** keys when watching DVD videos or animation, or playing a video game.*

Controlling Volume

You can adjust the output volume of your computer with the following steps.

1. Click *start - Control Panel*.
2. Click *Sounds, Speech, and Audio Devices*; then, *Sounds and Audio Devices*. If Classic view is selected, double-click *Sounds and Audio Devices* icon.
3. In *Sounds and Audio Devices Properties* dialog box, slide the lever to control the output volume.
4. Click *OK* and close the *Control Panel* window.



You can also easily adjust the volume in the window that will open when clicking the speaker symbol on the taskbar. When the symbol is not on the taskbar, check the box of Place volume icon in the taskbar in the step 3.

2

If you want to control the output volume of each source individually:

1. Click *start - Control Panel*.
2. Click *Sounds, Speech, and Audio Devices*; then, *Sounds and Audio Devices*. If Classic view is selected, double-click *Sounds and Audio Devices* icon.
3. In *Volume* tab of the *Sounds and Audio Devices Properties* dialog box, click *Advanced...* button of *Device volume* field.
4. Slide the lever of the source that you want to control.
5. Close the dialog box, then; click *OK* and close the *Control Panel* window.

If you control:

- Wave** → Controlling the volume of WAVE file
- SW Synth** → Controlling the volume of MIDI file

Adjusting Display

You can adjust the brightness, resolution, and number of colors of the internal LCD display for more comfortable viewing.

Changing Brightness of Display

Press and hold **Fn** key and then, press **F6** () key to decrease the brightness of the internal LCD display.

Press and hold **Fn** key and then, press **F7** () key to increase the brightness of the internal LCD display.

Changing Resolution and Number of Colors

When shipped, your computer is set to the default resolution and color. The default resolution is 1024 x 768 at 64K colors. To change the resolution and the number of colors, follow the instructions below:

1. In the *Display Properties* dialog box, select *Settings* tab.
2. Select the number of the colors in the *Color quality*, and select the resolution in the *Screen resolution*. Refer to the table below.
3. Click *OK*; then, *Yes*.

Available Resolutions and Colors

Resolution	Number of Colors
800 x 600	64K, 16M ^(*2)
1024 x 768	64K, 16M ^(*2)
1280 x 1024 ^(*1)	64K, 16M
1400 x 1050 ^(*1)	64K, 16M
1600 x 1200 ^(*1)	64K, 16M

^(*1) Can be chosen for an external monitor only when it is capable of the listed resolution modes. Cannot be set when displaying on the LCD monitor only and on the LCD and the external monitor simultaneously.

^(*2) On the internal LCD screen, the number of colors in this mode is made using a Dithering algorithm.



- When you use the tablet pen at an 800 x 600 resolution, follow these instructions to set the full screen mode. Otherwise, the cursor on the screen will mismatch the tip of the pen.
 1. In the *Settings* tab of the *Display Properties* dialog box, click

Advanced *button*.

2. Click Intel(R) Extreme Graphics *tab* and Graphics Properties... *button*.
 3. Check the box of Full Screen [No Border] and click *OK*.
 4. Click *OK* three times, and then, close the window.
- You cannot switch to display resolutions and number of colors that are not available.
 - In the Color quality, Medium (16 bit) means 65,536 (64K) colors, and Highest (32 bit) means about 16,770,000 (16M) colors.
 - If you select Highest;
 - Drawing speed may be delayed.
 - Wzshen playing animation, the screen may be distorted.

Rotating Image on Screen

You can adjust the screen orientation depending on the usage situation. Refer to *Adjusting Screen Orientation* section in Chapter 3.

Changing Wallpaper and Setting Screen Saver

You can enjoy various desktop patterns or screen savers.

Changing Wallpaper

1. In the *Display Properties* dialog box, select *Desktop* tab.
2. Select appropriate wallpaper in *Background* field.
3. Click *OK*.

Setting Screen Saver

1. In the *Display Properties* dialog box, select *Screen Saver* tab.
2. Select an appropriate screen saver from the pull-down menu in *Screen saver* field and set time when screen saver starts.
3. Click *OK*.



To disable the screen saver, select [None] from the Screen saver pull-down menu.

Sharing Your Computer

If you are sharing your computer with your colleagues or family members, set a user account for each person. Every user can choose his/her favorite desktop setting, web site lists, or make his/her own *My Documents* folder etc., and save them to his/her user account. When you turn on your computer, select your user account.

Set New User Account

1. Click *start - Control Panel*.
2. Click *User Accounts*. If Classic view is selected, double-click *User Accounts* icon.
3. Click *Create a new account* string.
4. Type a name for the new account and click *Next*.
5. Select the account type; then, click *Create Account*. If you have selected a *Limited* account, then that user account has limits for using your computer. See *Help and Support Center* in *start* menu for more details.
6. Close *User Accounts* dialog box; then, the *Control Panel*.

If more than one user account are set to your computer, you must select your account when logging on Windows.

Log off Your Computer

“Log off” is useful because you do not have to turn off your computer when you finish your task and pass your computer to another person. There are two ways to log off your computer; *Switch User* and *Log Off*.

If you select *Switch User*, you can pass your computer to another person without closing your current applications. For example, if you are viewing a Web site, and your colleague needs to open a program on your computer, use *Switch User*. You can then view the same Web site by just switching back to your account after your colleague finishes with your computer.

If you select *Log Off*, the system will close all your session and you need to save your files before logging off your computer.

1. Click *start - Log Off*.

2. Select *Switch User* or *Log Off*. If you select *Log Off*, the dialog box that asks you to save your data may appear.



- *If you cannot see Switch User in Log Off Windows dialog box, click Change the way users log on or off string in User Accounts dialog box, and check Use Fast User Switching and click Apply Options.*
- *The on-screen keyboard may hide some account names. In that case, move it to show all the accounts.*

3. Select another account to start Windows again.

Set Password to User Account

You can set a password to each user account to avoid unauthorized use of your computer. Once you set the password, you need to enter it when you log on to your account. If the entered password is not correct, you cannot start your computer with the user account. Unnecessary password setting can cause trouble in starting the system.



Your computer distinguish between upper- and lower-cases for user passwords.

Setting Password

1. Click *start - Control Panel*.
2. Click *User Accounts*. If Classic view is selected, double-click *User Accounts* icon.
3. Select the account to be set a password. You will only have this option if you log onto your computer as a member of the Computer administrators group. If you log on your computer with a limited user account, skip this step. (You cannot set a password to another user account.)
4. Select *Create a password* string.



- *If the password has been already set, Create a password will not appear.*
- *Only the members of the Computer administrators group can set a password to another user account.*

5. Type a new password.
6. Type the new password again to confirm it.
7. If necessary, type a password hints word to remember the password you set.

8. Click *Create Password*.
9. If you are asked whether you want to make your files and folders private, click *Yes, Make Private* or *No*. If not, go to the next step.
10. Close the *User Accounts* dialog box; then, the *Control Panel* window.

Changing Password

1. Follow the steps 1-2 on *Setting Password* section.
2. Select the account to be changed, if you log on to your computer as a member of the Computer administrators group. If you log on your computer with a limited account, skip this step. (You cannot change the password for another user account.)
3. Select *Change my password* string or *Change the password* string.



- *If the password has not been set yet, Change my password or Change the password will not appear.*
- *Only the members of the Computer administrators group can change the password of another user account.*

4. Type the current password. If you are changing another user's password, skip this step.
5. Type a new password.
6. Type the new password again to confirm it.
7. If necessary, type a password hints word to remember the password you set.
8. Click *Change Password*.
9. Close the *User Accounts* dialog box; then, the *Control Panel* window.

Deleting Password

1. Follow the steps 1-2 on *Setting Password*.
2. Select the account to be deleted, if you log on to your computer as a member of the Computer administrators group. If you log on your computer with a limited account, skip this step. (You cannot delete the password of another user account.)
3. Select *Remove my password* string or *Remove the password* string.



- *If the password has not been set yet, Remove my password or Remove the password will not appear.*
- *Only a member of the Computer administrators group can delete the password of another user account.*

4. Type your password and click *Remove Password*. If you log on your computer as a member of the Computer administrators group and want to delete the password of another user account, just click *Remove Password*.
5. Close the *User Accounts* dialog box; then, the *Control Panel* window.

Tablet Mode

This chapter explains how to use your computer in tablet mode and the tablet pen.



In this chapter, you often see the expression “Tablet and Pen Settings dialog box.” To open the dialog box, use one of the following ways:

- *With the icon on the taskbar, Tap the Change tablet and pen settings icon () – Properties..., or just double-tap the icon.*
- *With the Control Panel,
 1. Tap start – Control Panel.
 2. Tap Printers and Other Hardware – Tablet and Pen Settings in the Category view, or double-tap Tablet and Pen Settings icon in the Classic view.*

Rotating Your Computer Display

Your computer display unit rotates 180 degrees and folds down to cover the keyboard and becomes tablet mode.

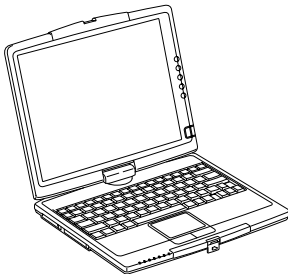

Notebook Mode

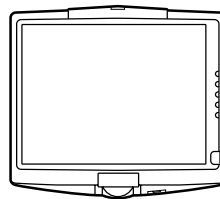

Tablet Mode

Switching to Tablet Mode

1. Open the display at an angle around 90 degrees.

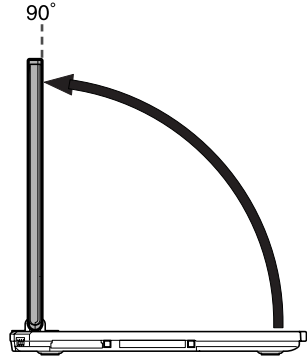
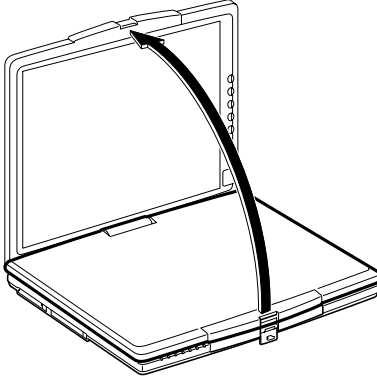

3



Be sure to set the display at an angle around 90 degrees. Otherwise the keyboard or cabinet of your computer will be damaged when rotating the display.

2. Hold the front left part of the cabinet with your left hand and the right side of the display with your right hand, then, softly rotate the display 180 degrees clockwise until it is set into place.

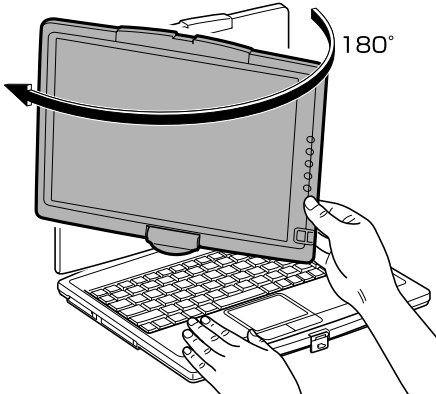

- *Be sure to slowly turn the display in the proper direction. Never rotate it with excessive force or speed. Otherwise your computer may be damaged.*
 - *Watch for your fingers when rotating the display.*
-

3. Fold the display over the keyboard ensuring it is aligned with the base cabinet and then, lock the display with the hook.

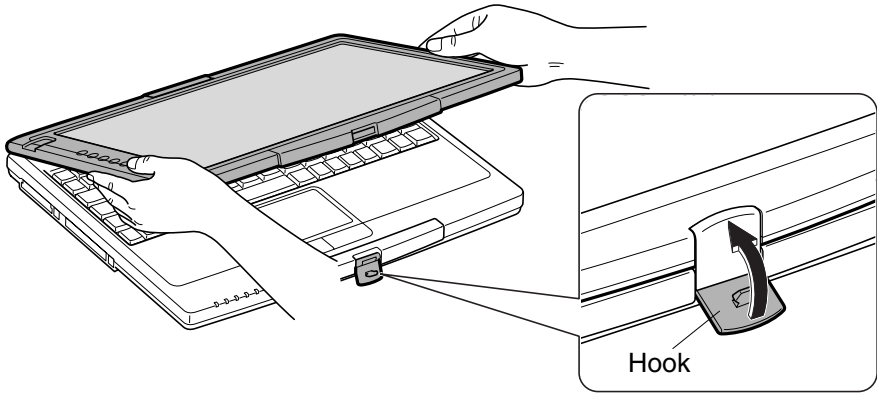

Be sure that the display cover and the base cabinet are aligned vertically before locking it. Trying to lock forcibly with the LCD placed out of alignment will damage the hook.



For rotating the screen image, refer to Adjusting Screen Orientation section later in this chapter.

Handling Your Computer in Tablet Mode



- *When you use your computer, holding it in your arm:*

 - *Do not cover the ventilation openings. Otherwise, the heated air from the openings may scald your hands or arms.*
 - *Disconnect the AC adapter and any peripherals connected by the cords.*

- *Care should be taken when using a protruding PC card such as a wireless LAN card from the card slot of your computer. Pressure onto the card may damage the card slot of your computer as well as the card itself.*
- *Do not use your computer on a walk or during driving.*
- *Never put your computer in tablet mode into a bag. The LCD screen may be damaged.*

Switching to Notebook Mode

1. Lift the display at an angle around 90 degrees.



Be sure to set the display at an angle around 90 degrees. Otherwise the keyboard or cabinet of your computer will be damaged when rotating the display.

2. Hold the cabinet with one hand and the display with other hand, then, rotate the display 180 degrees counterclockwise until it is set into place.

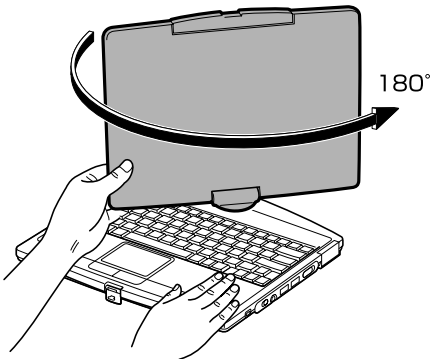

- *Be sure to slowly turn the display in the proper direction. Never rotate it with excessive force or speed. Otherwise your computer may be damaged.*
 - *Watch for your fingers when rotating the display.*
-

3. Set the display in comfortable view position.

Using Tablet Pen

An electronic pen called tablet pen comes with your computer. With it, you can select items just like mouse clicks, perform the program, and write characters or draw images directly on the screen.



Use only the tablet pen provided with your computer. Using other objects, such as a fingernail, pencil or others, may damage the screen surface.



- *The tablet pen adopts electromagnetic induction type for interacting with your computer, allowing the screen of your computer to sense the pen tip from a small distance produced just before or after direct contact. The characteristic may also cause unintentional cursor movement.*
- *Do not operate your computer with the tablet pen on any metallic object or near to electric devices such as radio base/relay station antennas, some information technology devices producing strong electromagnetic noise such as certain CRT monitors, etc. Your computer and tablet pen may not function properly due to radio interference.*

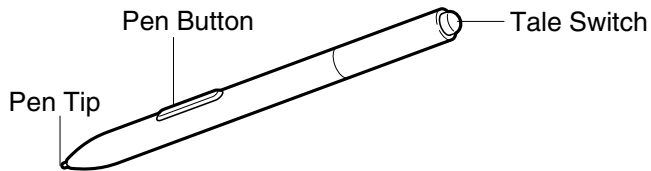

Handling Tablet Pen

- Do not use the pen for other purpose than operating your computer.
- Do not disassemble the tablet pen.
- Clean the pen tip and screen of your computer before using them.
- Do not touch or hold the pen with the dirty hand.
- Do not tap the pen on surfaces other than the screen of your computer.
- Do not press the screen strongly with the pen tip (this also may damage the screen surface).
- Never give an excessive pressure on the tip of the pen.

- Do not use the pen with the distorted tip. It may cause the pen to malfunction. Change the pen tip when it is distorted, sharp or short.
- Keep away something magnetic such as magnets, speakers, etc. from the pen and your computer when operating.
- Keep away the pen from excessive humidity or fluids such as rain, snow, water splay, juice, coffee, steam, etc.
- Do not use or store the pen in a place where the humidity changes appreciably or in a car exposed to direct sunlight.
- Never store the pen with the tip down such as in a pencil cup. Store it in the pen housing of your computer to avoid being damaged.
- Do not give an excessive pressure on the tale switch and pen button when stored. It may result in malfunction or deterioration of the pen.
- Never subject the pen to sudden shocks or extreme vibration. Be sure not to drop or shake the pen.
- Do not use alcohol, benzene, thinner or other strong chemical agents for cleaning the pen. Use a dry cloth.



Care must be taken for children not to swallow the pen tip.

Replacing Tip of Tablet Pen

The tablet pen tip will become sharp and short as used. The sharp tip may damage the surface of the LCD screen. Replace the pen tip if necessary.



- *Use one of the extra tips that come with the tablet pen.*
- *The pen tip will wear and become short with normal use. It may damage the internal LCD screen surface. Replace pen tip periodically to avoid this.*
- *Replace the pen tip before it becomes extremely short. Otherwise, you will have difficulty in clasping the tip.*

1. Clasp the old pen tip with a tip-replacing tool and pull it straight out of the pen.

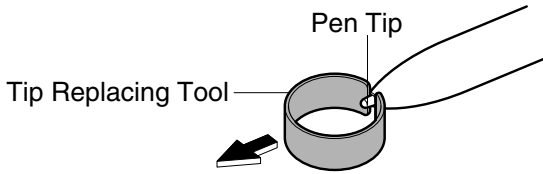

2. Clasp one of the extra tips with the tip-replacing tool and slide it straight into the barrel of the pen until it stops.

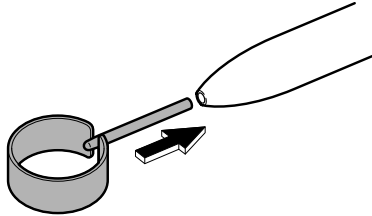

Inserting or Ejecting Tablet Pen

The provided tablet pen can be stored in the pen housing on the right side of your computer.



Be sure to store the tablet pen in the pen housing to protect it from damage when you are not using it.

Inserting

Insert the tablet pen with the tip first straight into the pen housing until you can hear the clicking sound.

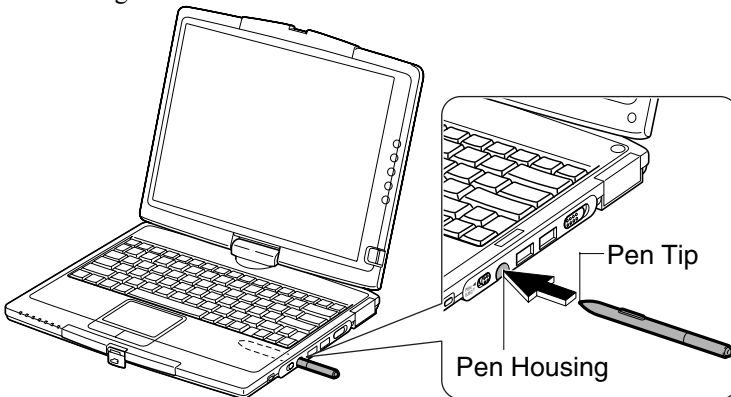

Ejecting

Slide the pen eject switch toward you so that the tablet pen will pop out and gently pull it straight out.

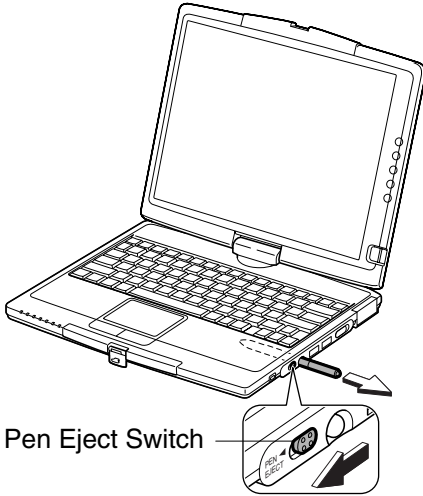

3

Using Tablet Pen as Mouse



Tapping, writing or dragging on the screen may cause the ink to seem spreading for a moment. Although it is not a major matter, try not to press strongly for avoiding the damage of the screen surface and the pen tip.

Selecting Items with Pen

To click an item as you would with the left button of the mouse, tap the item with the tip of the pen.

To double-click an item as you would with the left button of the mouse, tap the item twice with the tip of the pen.

To right-click an item as you would with the right button of the mouse, tap the item with the tip of the pen while pressing and holding the pen button. Or touch the item with the tip of the pen and keep touching for a few seconds so that the mouse icon (🖱️) will appear, then, lift the pen.

Drag and Drop



To drag and drop an item as you would with the mouse, double-tap and hold the pen tip pressed against the screen, then, move it. When the item reaches its destination, lift the pen tip from the screen.

Using Tablet Pen to Input Data

Your computer supports handwriting recognition technology and a software keyboard (or an on-screen keyboard) allowing you to write characters or draw images directly on the screen.

Input Panel

Input Panel is an input tool, installed on your computer, including a handwriting pad with quick keys and an on-screen keyboard.

To display the Input Panel, tap the *Show Pen Input Area* button () on the *Tablet PC Input Panel* title-bar located on the bottom of the screen. When the title-bar is not there, tap the *Tablet PC Input Panel* icon () on the left side of the taskbar. Refer to *Help of Input Panel* for more information.



To open the Help menu:

1. Tap *Tools* button located on the title-bar of the Input Panel.
2. Tap *Help* – Help Topics.

Windows Journal

Windows Journal is also an input tool, installed on your computer, allowing you to take notes on the screen in your handwriting just like on paper.

To run Windows Journal, tap *start* – *All Programs* – *Windows Journal*. Refer to *Help of Windows Journal* for more information.

Sticky Notes

Sticky Notes installed on your computer is utility tool allowing you to write down and keep names, telephone numbers or other information.

To run Sticky Notes, tap *start* – *All Programs* – *Sticky Notes*. Refer to *Help of Sticky Notes* for more information.

Using Tablet Pen to Erase Data

The provided tablet pen allows you to erase the input handwriting/drawing data on selected applications. Erasing style is slightly different between the applications. See *Help* menu of each application.

1. Hold the tablet pen upside down.
2. Rub the ink data with the tale switch just like you would with the eraser on the paper or press on a stroke of the ink data until the tale switch is pushed in.



Do not rub or press the data on the screen strongly. It may damage the surface of the screen.

Calibrating Tablet Pen

When the accuracy of the pen is poor (for example, the cursor on the screen mismatches the tip of the pen), you can calibrate the pen to accurately align the cursor with the pen tip. Follow these instructions.

1. Open *Tablet and Pen Settings* dialog box.
2. In *Calibration* field on *Settings* tab, select an orientation from the pull-down menu, then, tap *Calibrate...* button. The calibration screen will appear.
3. Tap the cross hair each time it appears, then, tap *OK* button.
4. Tap *OK* button.

Adjusting Screen Orientation

You can adjust the screen orientation depending on the usage situation. Your computer supports 90, 180 and 270-degree screen rotations. There are four views as shown below.

Primary landscape



Secondary landscape



Primary portrait

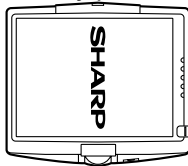

Secondary portrait

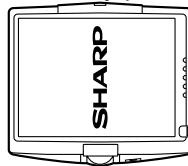



- *Be sure to use the Primary landscape view when you play 3D games, 3D screensavers, animations or DVD videos. Otherwise, they cannot be displayed properly.*
- *You cannot rotate the screen image when running one of the following items on the screen. End the task, then, rotate the screen.*
 - *Applications or games incorporating automatic resolution switching function*
 - *Command Prompt in maximized screen mode*
 - *3D screensavers*
- *When the screen orientation is set in primary portrait, secondary portrait, or secondary landscape, the pointer on the screen does not move in the same direction as your fingertip moves on the glide pad.*

To adjust the orientation, use one of the following ways:

- With one of the programmable buttons
Refer to the *Using Programmable Button* section.
- With the *Change tablet and pen settings* icon ()
 1. Tap the icon on the taskbar.
 2. Tap *Change screen orientation*.



- *Each time you tap Change screen orientation you will step to the next choice. The choices, in order, are: Primary portrait, Secondary landscape, Secondary portrait, and Primary landscape.*
- *You can change the switch order with the following steps.*
 1. *In Tablet and Pen Settings dialog box, tap Display tab.*
 2. *Tap Change... button.*
 3. *In Orientation Sequence Settings dialog box, change the order and tap OK twice.*

- With Hot Keys

The default settings are below:

Key Combination	Rotation Degree	Screen Orientation
Ctrl+Alt+[↑]	0-degree rotation	Primary landscape view
Ctrl+Alt+[→]	90-degree rotation	Primary portrait view
Ctrl+Alt+[↓]	180- degree rotation	Secondary landscape view
Ctrl+Alt+[←]	270-degree rotation	Secondary portrait view



You can change the hot key combination with the following steps:

1. Open Display Properties dialog box.
2. Tap Settings tab – Advanced button – Intel(R) Extreme Graphics tab.
3. Tap Graphics Properties button - Hot Keys tab.
4. Tap the key combination in the right column to be changed so that a pull-down menu will appear.
5. Select an appropriate one, then, tap OK three times.

- With Control Panel

1. In Tablet and Pen Settings dialog box, tap Display tab.
2. Select an appropriate view from Orientation pull-down menu.
3. Tap OK.

3 Using Programmable Button

Your computer provides a Windows security button and four programmable buttons located on the right side of the display. You can have settings of the programmable buttons for applications individually as well as each user.

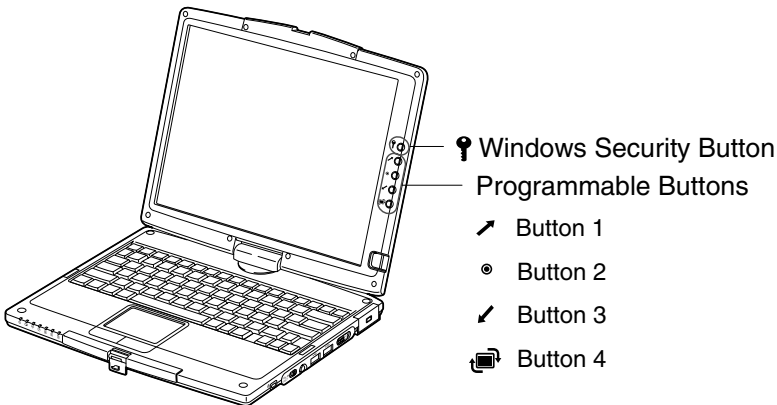

Windows Security Button (🔑)

This button is equivalent to **Ctrl+Alt+Del** keys combination. (You cannot change the setting of this button.)

Programmable Button

The programmable buttons work just like shortcut keys. Pressing one of the buttons gives you the assigned action depending on application. Refer to the next section for more information on the programmable buttons.

The Default actions and the assigned actions for the registered applications are below.

Application	(↖) Button 1	(⊙) Button 2	(↗) Button 3	(📺) Button 4
Default	Up	Enter	Down	Rotate Screen
Internet Explorer	Page up	WLAN On/Off	Page down	Rotate Screen
Windows Journal	Cut	Copy	Paste	Undo



Each time you press the Button 4 (when assigned to Rotate Screen), you will move to the next choice. The choices, in order, are: Primary portrait, Secondary landscape, Secondary portrait, and Primary landscape. To change the order, refer to the With the Change tablet and pen settings icon (📺) section on page 3-11.

3

Configuring Programmable Button

The programmable buttons can be assigned to selected actions depending on applications. The settings of the buttons can be also changed for various user accounts. Use *Programmable Buttons Enhanced Utility* for the programmable button configuration.

To run the utility, tap *Programmable Buttons Enhanced Utility* icon (📺) on the taskbar and select *Settings*. When the icon is not there, tap *start – All Programs – Sharp Utilities – Programmable Buttons Enhanced Utility*.



Be sure to always use the Programmable Buttons Enhanced Utility to configure the programmable button settings. Using other ways such as Windows XP Control Panel will cause malfunction of the programmable buttons.

Programmable Buttons Enhanced Utility Menu

When you tap *Programmable Buttons Enhanced Utility* icon (🔧) on the taskbar, the pop-up menu will appear. It provides information such as which applications have their own programmable button actions, how to configure the settings, etc.



When you have assigned new actions to the buttons in a non-registered application, the application name will appear in the menu.

Auto change allows your computer automatically to load the stored settings of the programmable buttons with switching between applications.



You can disable the Auto change function for the registered application individually as well as all together. Refer to Disabling Auto Switching section later in this chapter.

Always show the balloon allows the programmable button settings box to always display on the screen or not. (Refer to *Programmable Button Settings Box* section.)

Settings allows you to add new settings or modify or delete the registered ones.

About shows the *Programmable Buttons Enhanced Utility* version.

Quit quits the *Programmable Buttons Enhanced Utility*.

Creating New Setting



You cannot assign any actions to the programmable buttons in Command Prompt.

To register a new application and create new settings available in it:

1. Run an application(s) you want to register.



If you want to register more than one application, run all of them.

2. Tap the *Programmable Buttons Enhanced Utility* icon on the taskbar.
3. Select *Settings*.

4. In *Settings of Programmable Buttons Enhanced Utility* dialog box, tap *New* button. *Set Button Actions* dialog box will open.
5. Tap *Browse* button to display all currently running applications.
6. Select an application you want to register, then, tap *OK*. Confirm the application name appeared in *Name of Setting* field is correct.
7. Select an action from the pull-down menu of each button.



When you select Default option, each button will be assigned an action equivalent to the Default action. (See Programmable Button section earlier in this chapter for the Default action.)

8. Tap *OK*. If you have more applications to be registered, repeat the step 4 to 8. If not, go to the next step.
9. Tap *OK*.

Modifying Setting

To modify the settings of the registered application(s):

1. Tap the *Programmable Buttons Enhanced Utility* icon on the taskbar.
2. Select *Settings*.
3. In *Settings of Programmable Buttons Enhanced Utility* dialog box, select the application in *Name* column you want to change and then, tap *Edit* button. *Set Button Actions* dialog box will open.
4. Change the action by selecting new one from the pull-down menu of each button.
5. Tap *OK* twice.

Copying Setting

To copy the settings of a registered application to a new one:

1. Run an application(s) you want to copy to.



Be sure the application(s) has not been registered yet. You can not use copy function to the registered applications.

2. Tap the *Programmable Buttons Enhanced Utility* icon on the taskbar.
3. Select *Settings*.

4. In *Settings of Programmable Buttons Enhanced Utility* dialog box, select the source application in *Name* column and then, tap *Copy* button. *Set Button Actions* dialog box will open.
5. Tap *Browse* button to display a destination application(s).
6. Select a destination item, then, tap *OK*. Confirm the application name appeared in *Name of Setting* field is correct.



You can apply changes to the programmable buttons individually if desired. Select new one from the pull-down menu of each button.

7. Tap *OK* twice.

Deleting Setting



You cannot delete the Default settings.

To delete the settings of the registered application(s):

1. Tap the *Programmable Buttons Enhanced Utility* icon on the taskbar.
2. Select *Settings*.
3. In *Settings of Programmable Buttons Enhanced Utility* dialog box, select the application in *Name* column to be deleted and tap *Delete* button.
4. Tap *Yes*, then, *OK* button.

Disabling Auto Switching

When you don't like the programmable button settings to change automatically with application switching, follow these instructions.

- Disabling this function for all the registered applications
 1. Tap the *Programmable Buttons Enhanced Utility* icon on the taskbar.
 2. Select *Settings*.
 3. In *Settings of Programmable Buttons Enhanced Utility* dialog box, uncheck the box of *Change the function when window is activated*.
 4. Tap *OK* button.

- Disabling this function for the registered applications individually
1. Tap the *Programmable Buttons Enhanced Utility* icon on the taskbar.
 2. Select *Settings*.
 3. In *Settings of Programmable Buttons Enhanced Utility* dialog box, uncheck the box of the application in *Auto Change* column.
 4. Tap *OK* button.

Loading Other Setting

To load the programmable button settings assigned to an application other than the activated one, tap *Programmable Buttons Enhanced Utility* icon on the taskbar, then the application.



This performance disables the auto switching function. To enable the function, select Auto change from the Programmable Buttons Enhanced Utility menu.

Programmable Button Settings Box

You have a programmable button settings box on the screen with button action icons and names inside identifying the active functions of the programmable buttons.

To change the arrangement of the button icons when the screen image is rotated, check the box of *Automatically rearrange the button icons to suit the screen orientations* in the *Settings of Programmable Buttons Enhanced Utility* dialog box.

To hide the box, uncheck the box of *Always show the balloon* in the *Settings of Programmable Buttons Enhanced Utility* dialog box.



It takes a few seconds for the balloon to hide.

To display only icons in the box, resulting in the smaller box, uncheck the box of *Show the name of the function* in the *Settings of Programmable Buttons Enhanced Utility* dialog box.

Battery and Power Management

This chapter explains how to manage your computer's power effectively and use the battery pack.



In this section, you often see the expression “Power Options Properties dialog box”. To open the dialog box:

- 1. Click start - Control Panel.*
- 2. Click Performance and Maintenance - Power Options in Category view or double-click Power Options icon in Classic view.*

Battery Pack

When not connected to an external power source, your computer operates with the rechargeable battery pack. The duration of the battery life may be longer if your computer's power management is active. See the next section for power management.

To keep the battery life long:

- Condition the battery pack if the actual remaining power in your battery is less than what Windows *Power Meter* indicates. (See *Conditioning Battery Pack* section in this chapter.)
- Turn off your computer when you are not using it.



- *The duration of the battery depends on your computer usage. Using applications, which heavily use external peripherals, will result in shorter battery life.*
- *When using your computer powered on battery for several hours, enable power management and set System hibernate. Refer to the Power Management section in this chapter.*
- *When the battery has not been charged, your computer may not operate properly. Connect your computer to AC power source for the battery charging.*

Charging Battery Pack

1. Connect the AC adapter to your computer. While the battery is being charged, the battery indicator lights orange.
2. When the battery is fully charged, the battery indicator turns green. Charging time may vary according to the status of your computer.



- *The battery indicator may turn off even while the battery pack is being charged. This is because the battery pack is hot, and the charging stops temporarily. When the battery becomes cool, the charging will start and the battery indicator will turn on again.*
- *The battery pack may not be installed correctly if the battery indicator blinks orange. In this case, turn off your computer, remove the AC adapter and the battery pack; then, install the battery pack and connect the AC adapter again. If the battery indicator still blinks orange, ask your local dealer for assistance.*
- *When the battery pack is hot (for example, after a long use), it may take longer to be fully charged.*

4

Checking Battery Level

You can check the battery level by placing the pointer on the battery icon (🔋 : powered on battery) or AC plug icon (🔌 : powered on AC power and charging the battery pack) on the taskbar, or double-clicking one of these icons (🔋, 🔌 or 🔌 : powered on AC power) to open the *Power Meter* dialog box. If the battery is fully charged, remaining capacity level will not appear even if you point to the icon.

If you cannot see the battery or AC plug icon, follow these instructions:

1. In the *Power Options Properties* dialog box, select *Advanced* tab.
2. Check *Always show icon on the taskbar* and click *OK*.
3. Close the *Control Panel* window.



- *The remaining operating time depends on the power you are consuming. If you are using the audio system, PC card slot, CF card slot, hard disk drive, or peripheral devices with your computer, it may consume more battery power.*
- *If the actual remaining power in your battery is less than what Windows Power Meter indicates, you should condition the battery pack as per the procedure on Conditioning Battery Pack section in this chapter.*

Low Battery Indication

When the battery power becomes significantly low, the battery indicator (🔋) blinks red, the warning beep sounds. Save your data and turn off your computer, or connect your computer to AC power immediately. Otherwise, your computer will be shut down and the data may be lost.

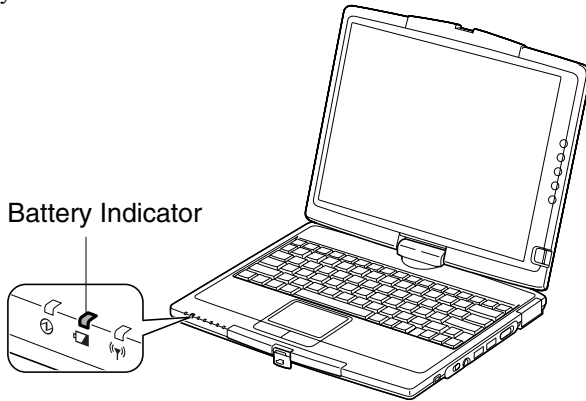

On Windows, a beep sound or an on-screen message will tell you when the battery drops to the specified level and your computer will go on *System standby/System hibernate* or shut down automatically.

To set Windows battery alarm:

1. In the *Power Options Properties* dialog box, select *Alarms* tab.
2. Set the battery level at which the alarms are activated. We recommend you set *Critical battery alarm* to 5 % or more and *Low battery alarm* to more than the value of *Critical battery alarm*.
3. Set the *Alarm Action...* to the appropriate settings.
4. Click *OK* twice.
5. Close the *Control Panel* window.

Conditioning Battery Pack

When the actual remaining power in your battery is less than what Windows Power Meter indicates, you need to condition the battery pack or buy a new one.

1. Make sure your computer is turned off. Connect your computer to AC power and wait until the battery is fully charged. The battery indicator turns orange first; then, turns to green when the battery pack is fully charged.



When the battery is full charged, the battery indicator turns green.

2. Turn on your computer and press **F2** to open the Setup Utility when the message *Press F2 for System Utilities* appears.
3. Disconnect the AC adapter.
4. Leave your computer on until the battery is completely discharged and the system shuts down automatically.
5. Connect your computer to AC power source and let the battery fully charged again.



- *Do not turn on your computer while charging the battery pack.*
- *Do not connect your computer to a wall outlet while discharging the battery. The conditioning will be cancelled.*



Repeated charging and discharging or long-term storage of the battery pack cause battery deterioration. In this case, replace the battery pack with a new one.

Changing Battery Pack

When the battery pack is repeatedly charged and discharged or stored for a long term, it will deteriorate (the deterioration rate depends on the operating environment). The battery deterioration will result in declining its capacity and power. If the battery life becomes extremely short even after the conditioning, you should buy a new battery pack. Ask your local dealer for a new battery pack.

When you replace the battery pack with a new one:

1. Turn off your computer and disconnect the AC adapter from your computer.
2. Close the display cover and turn your computer over on a stable surface.



Never close the display with the LCD face up (in tablet mode) when you change the battery pack.

3. Unlock the battery stopper of your computer to the left and hold it; then, unlock the battery release lever of the battery pack to the left and hold it; then, pull out the battery pack.

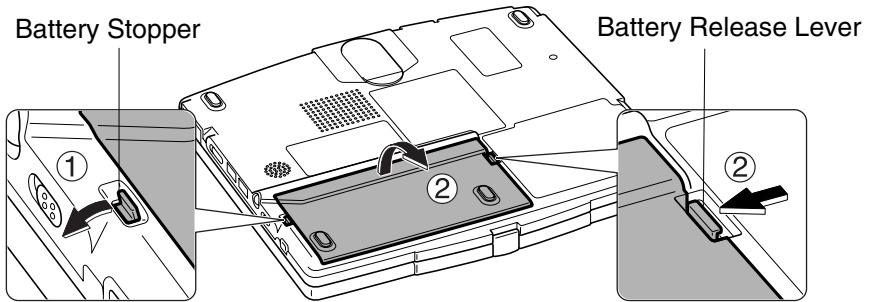

4. Insert a new battery pack into your computer by matching the projected parts of the battery with the notched parts on your computer.

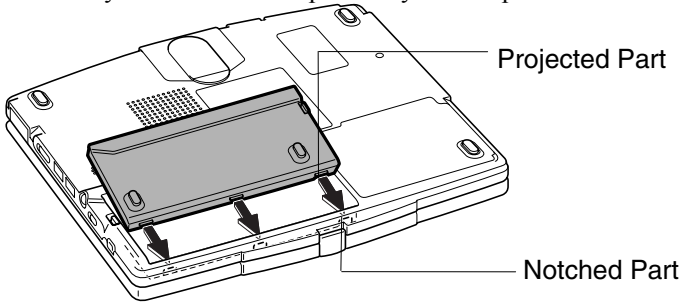

5. Push the battery pack until you hear the clicking sound.

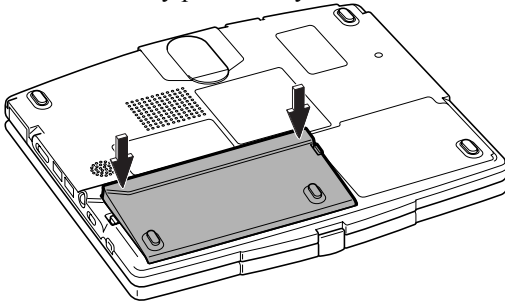

6. Turn your computer over.

Power Management

Power management saves electricity and extends battery life by controlling power supply to built-in devices. You can set the following power management properties on Windows.

- Stopping power supply to the hard disk
- Stopping power supply to the display
- Controlling CPU speed
- Using System standby/hibernate

To open *Power Options Properties* dialog box, click *start – Control Panel*, and click *Performance and Maintenance*; then, *Power Options*. If Classic view is selected, double-click *Power Options* icon.

4



Note that the power management may not seem to function when you are using an application program that accesses the hard disk periodically.

Stopping Power Supply to Hard Disk

1. In the *Power Options Properties* dialog box, select *Power Schemes* tab.
2. Set *Turn off hard disks* to an appropriate value, and click *OK*.
3. Close the *Control Panel* window.

Stopping Power Supply to Display



This procedure is also effective for an attached external monitor complying with power management.

1. In the *Power Options Properties* dialog box, select *Power Schemes* tab.
2. Set *Turn off monitor* to an appropriate value, and click *OK*.
3. Close the *Control Panel* window.

Controlling CPU Speed

Windows XP controls the processor performance to reduce power consumption.



Do not control the processor performance, or connect/disconnect the AC adapter while communicating, or reading/writing data. Otherwise your computer may malfunction.

1. In the *Power Options Properties* dialog box, select *Power Schemes* tab.
2. Select an appropriate power scheme in *Power schemes* according to the table below, and click *OK*.
3. Close the *Power Options Properties* dialog box; then the *Control Panel* window.

Power Scheme	Processor Performance	
Home/Office Desk	Using AC Power	Always runs at highest performance state
	Using Battery	Performance state will be chosen based on CPU demand
Portable/Laptop	Using AC Power	Performance state will be chosen based on CPU demand
	Using Battery	Performance state will be chosen based on CPU demand
Presentation	Using AC Power	Performance state will be chosen based on CPU demand
	Using Battery	Uses liner performance reduction as battery discharges
Always On	Using AC Power	Always runs at highest performance state
	Using Battery	Always runs at highest performance state
Minimal Power Management	Using AC Power	Performance state will be chosen based on CPU demand
	Using Battery	Performance state will be chosen based on CPU demand
Max Battery	Using AC Power	Performance state will be chosen based on CPU demand
	Using Battery	Uses liner performance reduction as battery discharges



- *Note that Power schemes includes other power management settings (such as a timer for System standby, etc.) appearing on Power Schemes tab. Confirm those settings are set to the appropriate value when you select the processor performance using power schemes facility.*
- *You can set your own power scheme. Set all power management settings to your suitable ones, and click Save as...; then, type an appropriate name and click OK.*
- *Once the preinstalled power scheme settings listed on the previous page are deleted, there is no way but re-installation to resume them.*

Using System Standby/Hibernate

System standby/hibernate is a very useful power management tool. For example, you can restart your computer from stand by mode more quickly than shut down mode. When your computer resumes from *System standby/hibernate*, the system restores the exact last state of your computer. On Windows, you can set the conditions under which the system enters *System standby* or *System hibernate*.

- *System standby* stores the current condition of your computer in RAM and stops power supply to all but a few essential components. Your system enters and resumes from *System standby* per the conditions mentioned later. In *System standby*, the power indicator blinks green. To resume from *System standby*, operate your computer again.
- *System hibernate* saves the current condition of your computer in part of the hard disk and turns off your computer. Your system enters and resumes from *System hibernate* per the conditions mentioned later. In *System hibernate* the power indicator is off. To resume from *System hibernate*, slide the power switch.



When entering/resuming from System standby/hibernate, follow the instructions below:

- *Finish communications, printing, and playing music or video before entering System standby/hibernate.*
 - *Do not operate your computer or peripheral devices, or connect/disconnect peripheral devices, while entering/resuming from System standby/hibernate.*
 - *While operating on battery that does not have enough power, your computer may not resume from System standby/hibernate. In this case, connect the AC adapter to your computer.*
 - *Save your data before your computer enters System standby. If the power supply to your computer is stopped, the RAM contents will be lost.*
 - *Select your user account if Windows requires when your computer has resumed from System standby/hibernate.*
-

Supporting System Hibernate



If your battery becomes completely discharged during System standby, you will lose unsaved data and will need to reboot your computer. Therefore, if you are planning to leave your computer powered by battery for long periods of time, we recommend System hibernate.

Confirm that *System hibernate* is supported with the following steps.

1. In the *Power Options Properties* dialog box, select *Hibernate* tab.
2. Confirm *Enable hibernation* is checked.
3. Click *OK*, then, close the *Control Panel* window.

Set Timer to Enter System Standby/Hibernate Automatically

Your computer will enter System standby/hibernate automatically when the specified time has passed without any operation. To set the time:

1. In the *Power Options Properties* dialog box, select *Power Schemes* tab.
2. From the pull-down menus of *System standby* or/and *System hibernates*, select the elapsed time before your computer automatically enters System standby/hibernate.
3. Click *OK* then, close the *Control Panel* window.

Entering System Standby/Hibernate

Your computer enters *System standby/hibernate* in each of the following cases:

- You select *Stand By* or *Hibernate* (which will replace *Stand By* if you press **Shift** key) in the *Turn off computer* dialog box. To open the dialog box, click *start – Turn Off Computer*.
- The specified time in *System standby* or *System hibernates* in *Power Schemes* tab of *Power Options Properties* dialog box has passed without any operation (See the previous section).
- The screen cover is closed.

The above functions if you perform the following:

1. In the *Power Options Properties* dialog box, select *Advanced* tab.
2. Select *Hibernate* or *Stand by* in *When I close the lid of my portable computer* field.
3. Click *OK*, then, close the *Control Panel* window.

- You slide the power switch.

The above functions if you perform the following:



1. In the *Power Options Properties* dialog box, select *Advanced* tab.
2. Select *Hibernate* or *Stand by* in *When I press the power button on my computer* field.
3. Click *OK*, then, close the *Control Panel* window.

- You press **Fn+F12** ()

The above functions if you perform the following:

1. In the *Power Options Properties* dialog box, select *Advanced* tab.
2. Select *Hibernate* or *Stand by* in *When I press the sleep button on my computer* field.
3. Click *OK*, then, close the *Control Panel* window.



*If Ask me what to do is selected in the step 2 of You slide the power switch or You press **Fn+F12** () , the Turn off computer dialog box will appear when you slide the power switch or **Fn+F12** () key combination. You can select System standby or System hibernate at that timing.*

- The battery level is low.

The above functions if you set the alarm on Windows. See *Low Battery Indication* earlier in this chapter.

Disabling Power Management

1. In the *Power Options Properties* dialog box, select *Power Schemes* tab.
2. Set *Turn off monitor*, *Turn off hard disks*, *System standby*, and *System hibernates* to *Never*; then, click *OK*.
3. Close the *Control Panel* window.

Peripherals

This chapter describes how to use peripheral devices with your computer. You can connect a floppy disk drive unit, a printer, an external monitor, an IEEE1394 device, or other devices to your computer. To ensure proper use, be sure to read the instructions for each peripheral device before connecting it to your computer.

Peripheral Device Connectors

Your computer has connectors for peripheral devices, shown on the next page. For connection, refer to the section explaining each device, or contact your dealer.





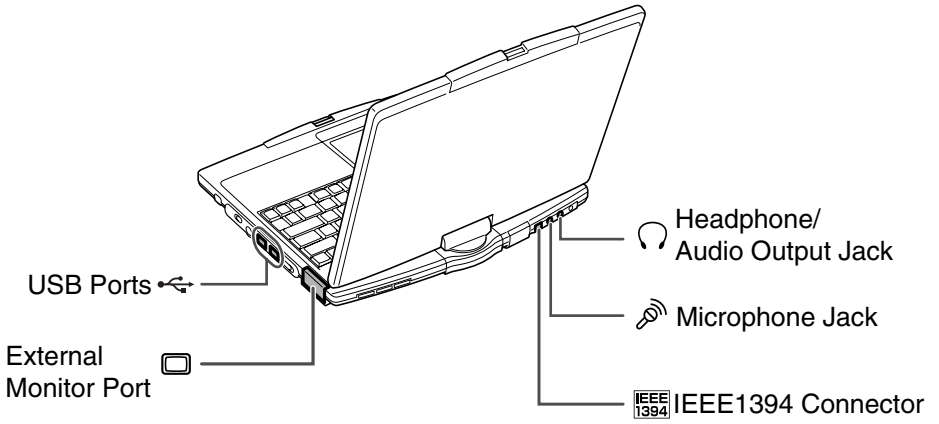

- *Be sure to turn off your computer and the peripheral devices before connecting them (except when inserting a PC card or a CF card, or connecting USB devices, an IEEE 1394 device, etc.).*
- *Confirm the peripheral device you will connect is Windows XP compatible.*
- *Some devices have to be turned on after your computer is turned on.*
- *Some devices require that you install the drivers before use (You may need to connect the optional external floppy disk drive unit or an external optical drive unit to install the drivers.)*

Connectors for Peripherals

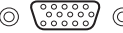

Connector Shape

Connector name	Connector shape
USB Port	
IEEE1394 Connector	
External Monitor Port	
Headphone/Audio Output Jack	
Microphone Jack	

Optional External Floppy Disk Drive Unit

You can use double-density (2DD) 720KB or high-density (2HD) 1.44MB floppy disks with the optional external floppy disk drive unit (CE-FD05).

Connecting Optional External Floppy Disk Drive Unit



- *Do not place the floppy disk drive unit on its side or upside down.*
 - *Do not press on the floppy disk drive unit. It may damage the drive or cause malfunction.*
 - *Do not place the AC adapter on the floppy disk drive unit. It may cause the drive to malfunction.*
-

Connect the floppy disk drive unit cable to either of the USB ports on the right side of your computer. Be sure to let the USB mark side up when connecting the cable to your computer.

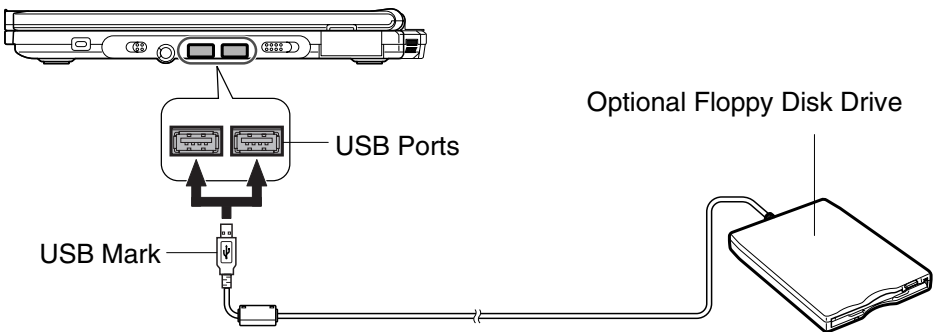

Handling Floppy Disks

- Do not open the shutter and touch the disk inside; otherwise, you will not be able to read or write data to the disk.
- Do not place floppy disks near magnets or heat source, in direct sunlight or in a dusty place, etc.
- Never subject a disk to sudden shocks or extreme vibration. Do not drop, bend, or place heavy objects on a disk.
- Do not spill liquid onto a disk.

Inserting Floppy Disk

Hold the floppy disk with the arrow facing up, toward the drive. Slide the disk into the drive until it locks into place.

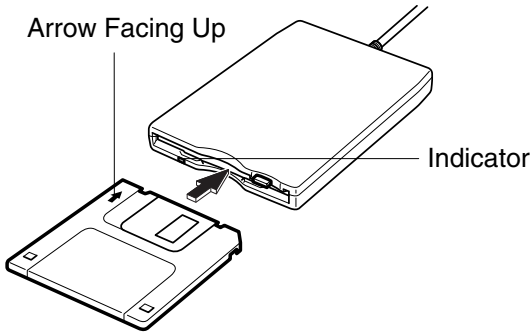

- *Always insert a floppy disk straight into the floppy disk drive.*
 - *When inserting the disk, make sure it is not upside down.*
 - *Do not use excessive force when inserting the floppy disk. If you have difficulty inserting or removing disks, seek the assistance of an authorized service technician.*
 - *Do not touch the disk while reading/writing data. It may cause malfunction of your computer and the drive.*
-

5

Ejecting Floppy Disk



Before ejecting the floppy disk, make sure the indicator of the floppy disk drive unit is not lit.

Press the eject button firmly. The disk pops out slightly. Eject it and store it properly.

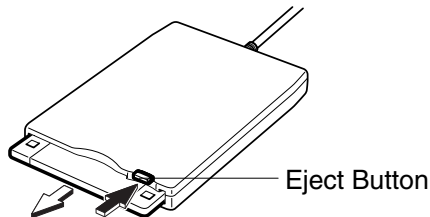

Formatting Floppy Disk

1. Make sure the floppy disk is not write-protected, and insert it into the floppy disk drive.
2. Click *start - My Computer*.
3. Right-click *3 1/2 Floppy (A:)* icon; then, click *Format...* from the pop-up menu.
4. Select the appropriate formatting options.
5. Click *Start* to start formatting.



- *When you format a floppy disk, all data previously stored on the disk is lost.*
 - *You cannot format a double-density (2DD) 720KB floppy disk.*
-

Removing Optional External Floppy Disk Drive Unit

To remove the unit, you need to perform the following steps before you remove it:

1. Click *Safely Remove Hardware* icon () on the taskbar.
2. Click *Safely remove Mitsumi USB Floppy – Drive(A:)*; then, *Safe To Remove Hardware* dialog appears.
3. Remove the unit from your computer.

External Display

You can use an external monitor with your computer. To display the images on both displays simultaneously, use the 1024x768 resolution.



- *Some monitors, which are not compatible with your computer, may not display correctly.*
- *In this section, you often see the expression “Display Properties dialog box.” To open the dialog box, right-click somewhere on the Windows desktop and select Properties from the pop-up menu.*

Connecting External Monitor

1. Turn off your computer and the external monitor.
2. Open the cover on the right side of your computer.

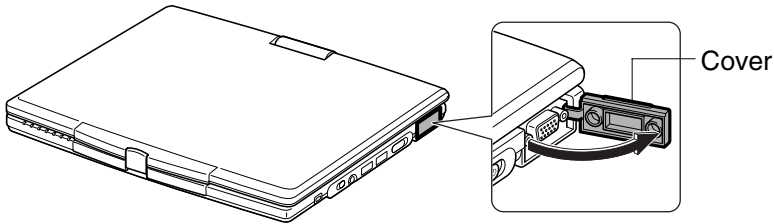

3. Connect one end of your external monitor cable to the external monitor port of the right side of your computer and the other to your external monitor. If the monitor cable has screws, tighten them.

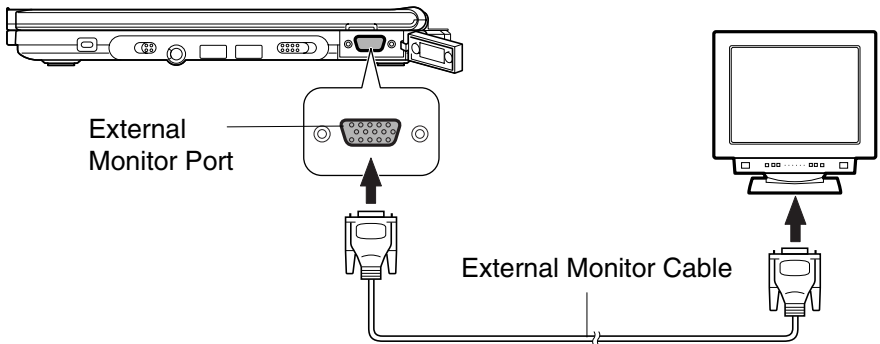

4. Turn on the external monitor; then, your computer.

Displaying on External Monitor

To display the image on an external monitor, you may need to install the driver for the external monitor. Before using the external monitor, refer to the manual included with it.

Switching Display

1. In *Display Properties* dialog box, select *Settings* tab; then, click *Advanced* button.
2. Select *Intel(R) Extreme Graphics* tab; then, click *Graphic Properties....*
3. Select an output display you want to view the image and click *OK*.
4. Click *OK* three times.



- You can also switch the display with **Fn+F5** (⌘).
- While playing video or animation, you may not be able to switch the display.

Disconnecting External Monitor

1. Turn off your computer and the external monitor.
2. Loosen the screws of the monitor cable if it has, and remove the cable from your computer and the monitor.
3. Close the cover.



Be sure to close the cover to avoid damaging the external monitor port.

Audio System

You can output sound to speakers, audio equipment or headphones.

Connecting Speakers

You can connect stereo speakers with an amplifier to the audio output jack on the rear side of your computer.

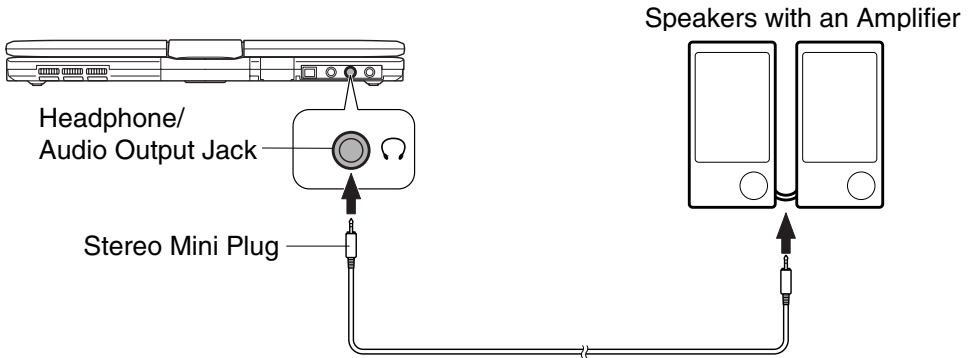

5 Connecting Audio Equipment

You can connect analog audio equipment to the audio output jack on the rear side of your computer.

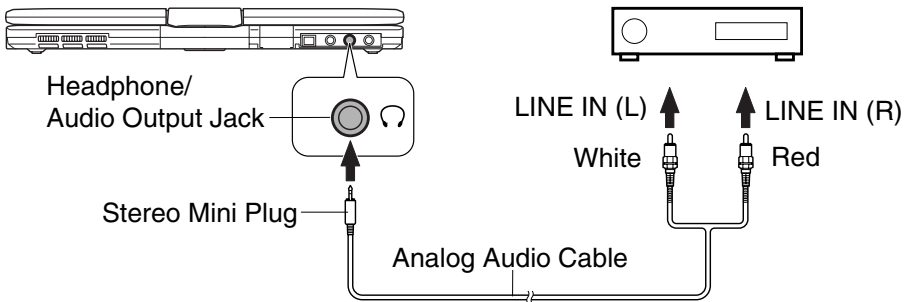

You can adjust the output volume on Windows by clicking the speaker symbol on the taskbar.

Connecting a Headphone

Use the headphone with an impedance of more than 8Ω . (32Ω is recommended.)

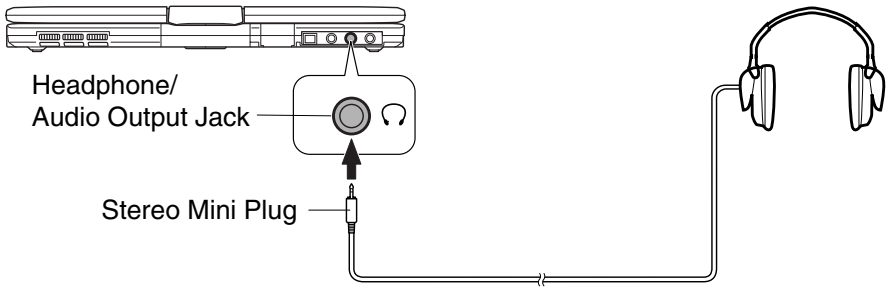

Connecting Microphone

You can input sound using an external microphone connected to the microphone jack. Use an electret condenser microphone with an impedance of $2.2k\Omega$ and an allowable voltage of $2V$.

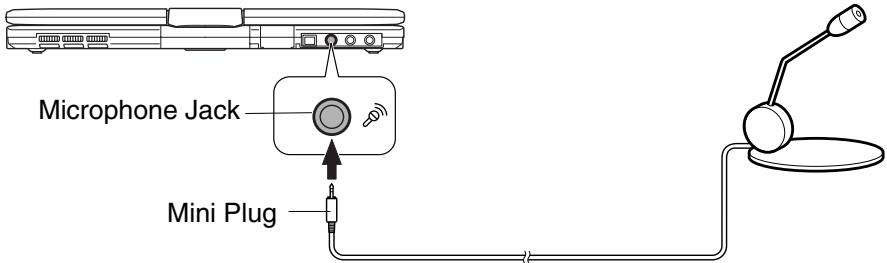

To record sound:

1. Click *start*; then, point *All Programs – Accessories – Entertainment*.
2. Click *Sound Recorder*.
3. See *Help* for *Sound Recorder* for more information.

USB Device



Your computer has an interface called Universal Serial Bus (USB) and its two USB ports support USB1.1 and USB2.0. With a USB connection, you can connect/disconnect peripherals without turning off your computer. Generally, when you connect a device to your computer, the necessary driver will be installed automatically. See also the manuals of peripheral devices supporting USB.

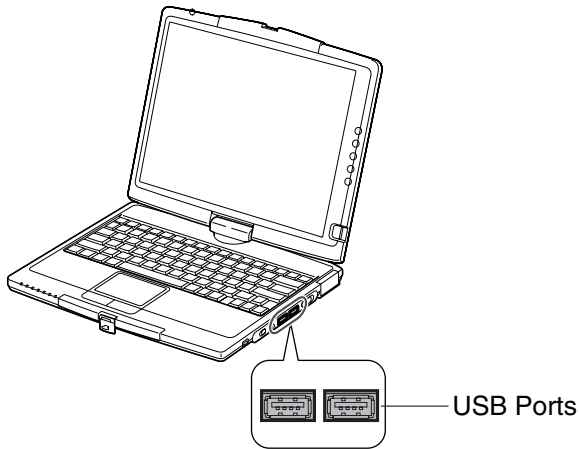

When a new device is correctly connected to your computer, the appropriate driver is automatically installed. If the driver is not installed correctly, you will see the message on the screen. In this case, install the driver with the instructions on the screen.



To remove USB devices, you may need to perform the following instructions before you remove them:

1. Click *Safely Remove Hardware* icon () on the taskbar. If you cannot find the icon, click  to show all kinds of icons. If the icon does not appear, go to Step3.
2. Click *Safely remove xxxx* (xxxxx is the name of your USB device); then, *Safe To Remove Hardware* dialog appears.
3. Remove the device from your computer.

PC Card

Your computer is equipped with a PC card (supporting PC Card Standard) slot, which can accommodate a Type II card or a CardBus compliant card. You can insert/eject the card without turning off your computer.

Inserting PC Card



When you insert a protruding PC card such as wireless networking card:

- *Do not give force to the card.*
- *Do not carry your computer with the card inserted.*



When a new card is correctly inserted, the appropriate driver is automatically installed. If the driver is not installed correctly, you will see the message on the screen. In this case, install the PC card driver by following the instructions on the screen.

1. Confirm the PC card eject button is inside your computer cabinet.

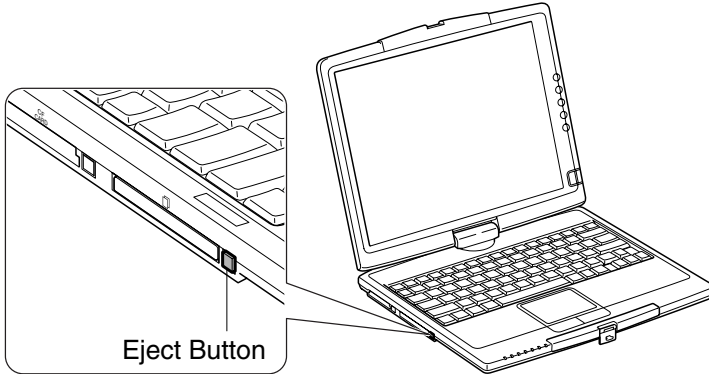

2. Push the PC card eject button so that it will pop out from the side of your computer.

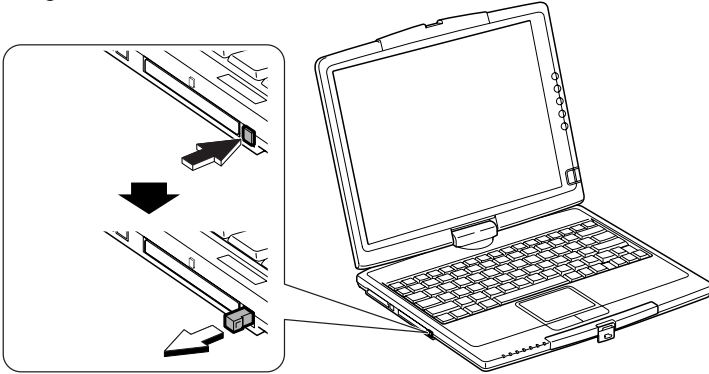

3. Push the PC card eject button again until the protection card pops out and remove it.

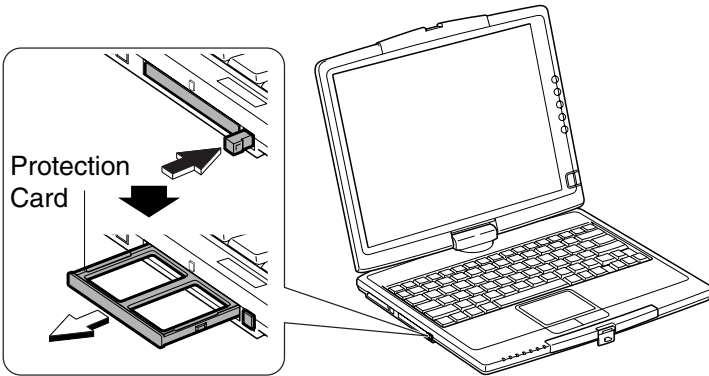

4. Push the PC card eject button all the way inside the cabinet for safekeeping.

5. Insert a PC card into the slot with the label face up until it is locked into place.

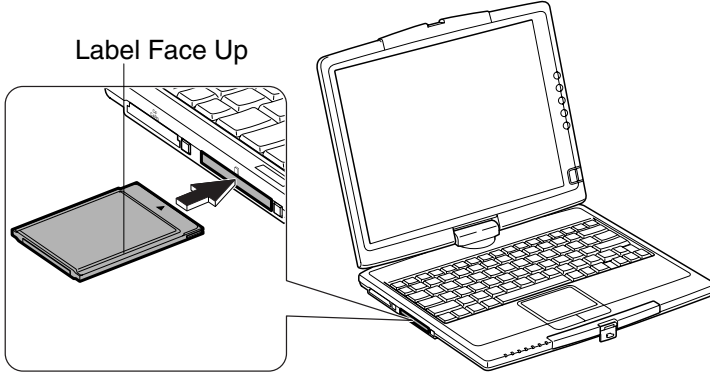



If the dialog box asking you *What do you want Windows to do?* appears, select the task you want.

Ejecting PC Card



- *Some PC cards may become hot after long use.*
- *Be sure to use the procedure below when ejecting a PC card. Otherwise, the system may not work properly.*

1. Click *Safely Remove Hardware* icon () on the taskbar. If you cannot find the icon, click  to show all kinds of icons.
2. Click *Safely remove xxxx* (xxxxx is the name of your PC card); then, *Safe To Remove Hardware* dialog appears.
3. Push the PC card eject button so that it will pop out from the side of your computer.

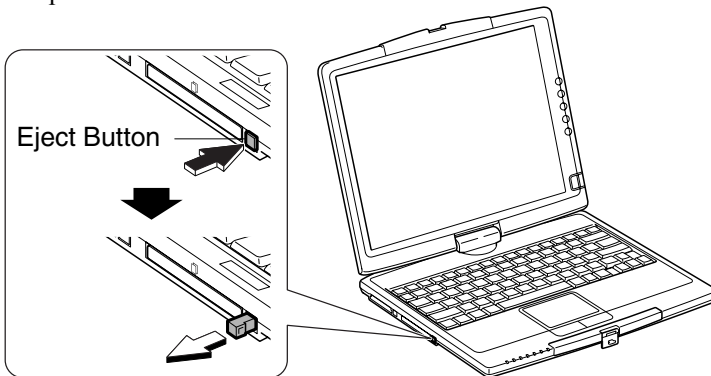

4. Push the eject button until the inserted PC card pops out and remove it.

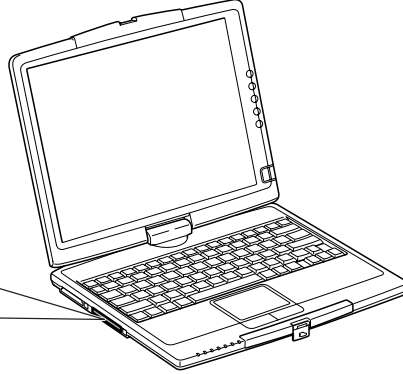
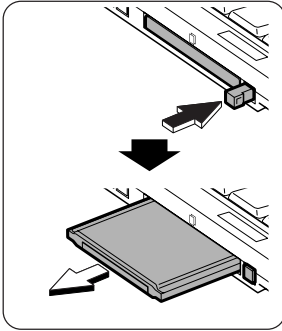

5. Push the PC card eject button all the way inside the cabinet for safekeeping.
6. Insert the protection card.

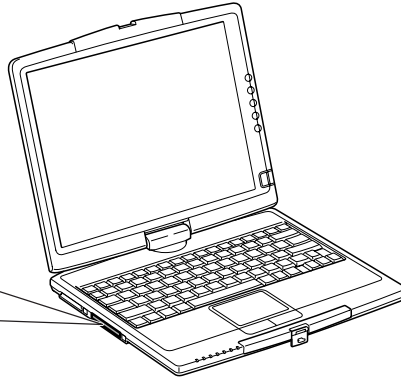
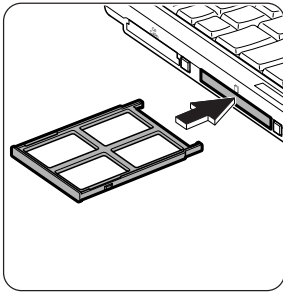

5



Be sure to insert the protection card after you finish using the PC card slot to protect the slot from being damaged.

Compact Flash Card

Your computer is equipped with a CF card slot, which can accommodate a Type II card compliant with CompactFlash standard. You can insert/eject the card without turning off your computer.

Inserting Compact Flash Card



When you insert a protruding compact flash card such as wireless networking card:

- *Do not give force to the card.*
- *Do not carry your computer with the card inserted.*



When a new card is correctly inserted, the appropriate driver is automatically installed. If the driver is not installed correctly, you will see the message on the screen. In this case, install the CF card driver by following the instructions on the screen.

- *You can insert a compact flash card without turning off your computer.*

1. Confirm the CF card eject button is inside your computer cabinet.

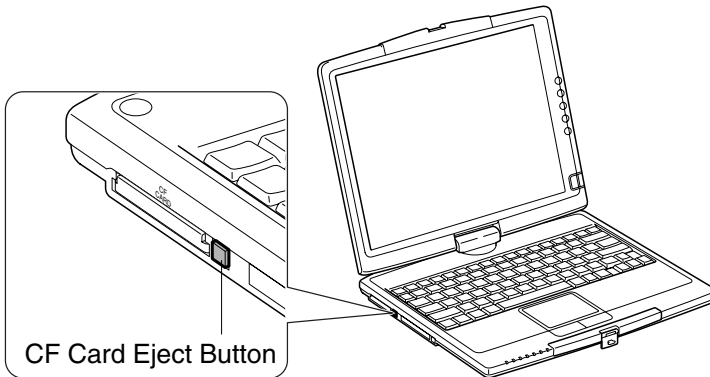

2. Push the CF card eject button so that it will pop out.

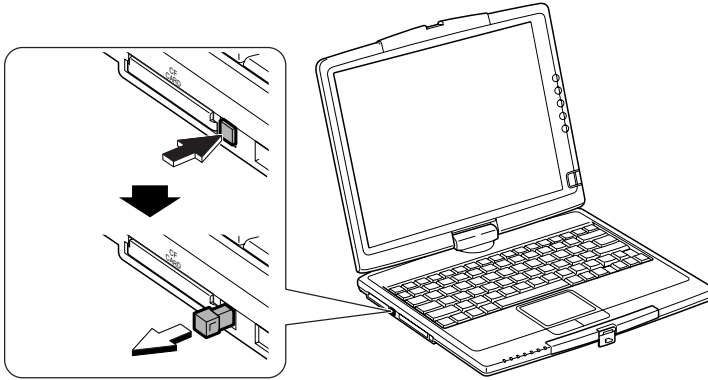

3. Push the CF card eject button again until the protection card pops out and remove it.

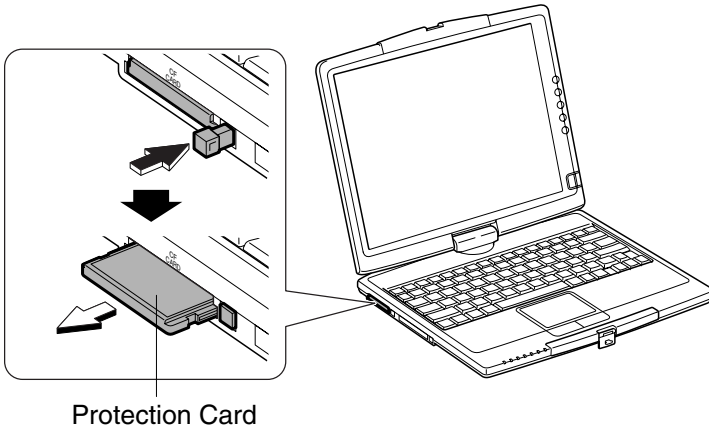

4. Push the CF card eject button all the way inside the cabinet for safekeeping.

5

5. Insert a compact flash card into the slot with the label face up until it is locked into place.

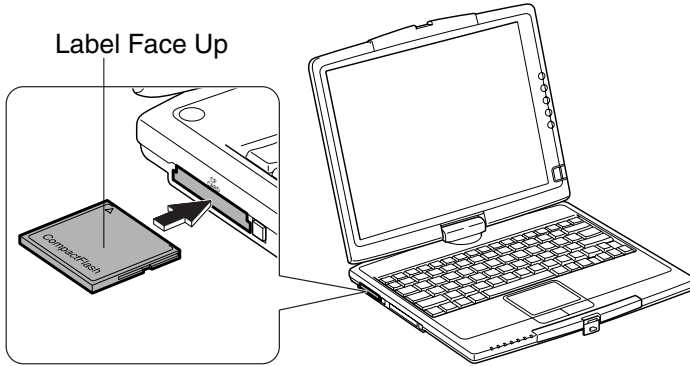



If the dialog box asking you *What do you want Windows to do?* appears, select the task you want.

Ejecting Compact Flash Card



- *Some compact flash cards may become hot after long use.*
 - *Be sure to use the procedure below when ejecting a compact flash card. Otherwise, the system may not work properly.*
-

1. Click *Safely Remove Hardware* icon () on the taskbar. If you cannot find the icon, click  to show all kinds of icons.
2. Click *Safely remove xxxx* (xxxxx is the name of your compact flash card); then, *Safe To Remove Hardware* dialog appears.

3. Push the CF card eject button so that it will pop out from the side of your computer.

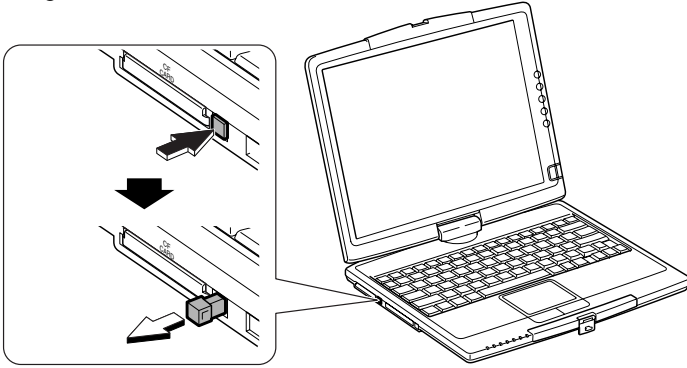

4. Push the eject button until the inserted compact flash card pops out and remove it.

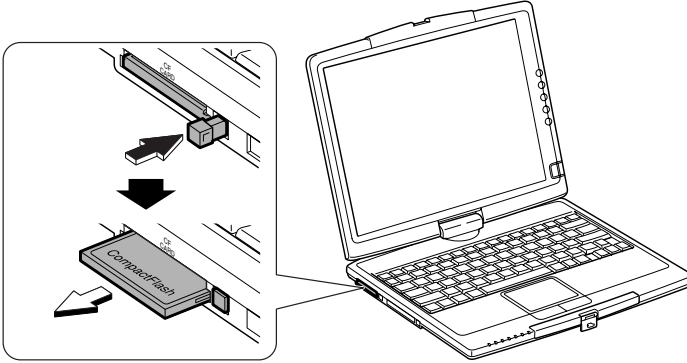

5. Push the CF card eject button all the way inside the cabinet for safekeeping.
6. Insert the protection card.

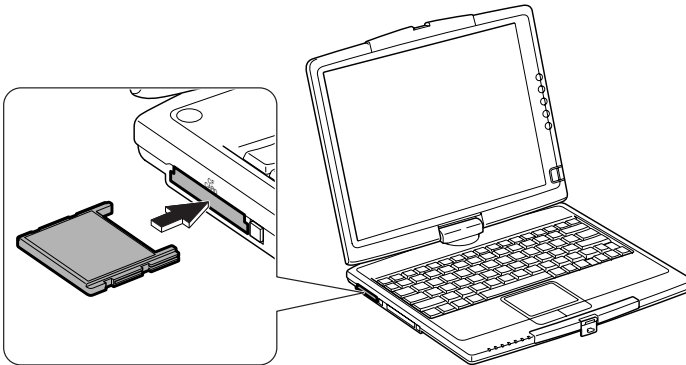



Be sure to insert the protection card after you finish using the CF card slot to protect the slot from being damaged.

Printer

You can connect a USB printer to either of the USB ports.



- *Before using a printer, read the printer manual and install the printer driver.*
- *Be sure to read the printer manual before connecting the USB printer to your computer. Some printers may not use Found New Hardware Wizard to install the printer driver.*
- *You can connect the USB printer to your computer without turning off your computer.*

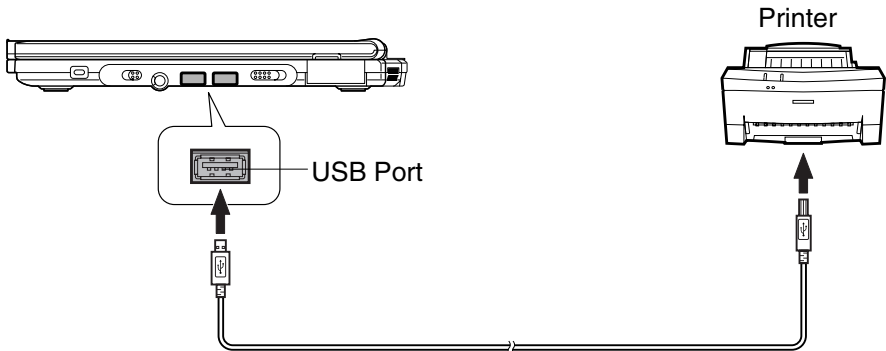

IEEE1394 Device

You can connect an IEEE1394 device to the IEEE1394 connector on the rear side of your computer. The IEEE1394 is digital interface for handling digital video, digital audio and other data in two directions between devices, and for controlling other equipment.

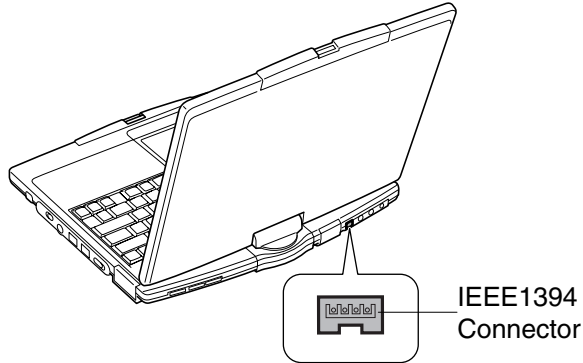

5

When two or more IEEE1394 compatible devices are connected to your computer in a daisy chain, operations and data transactions are possible not only with the equipment that is directly connected, but also with other devices via the directly connected device.



- *Confirm the IEEE1394 device you will connect is Windows XP compatible.*
- *Some IEEE1394 devices require that you install drivers before use.*
- *Use AC power source for your computer especially when reading/writing the data.*

Connecting IEEE1394 Device



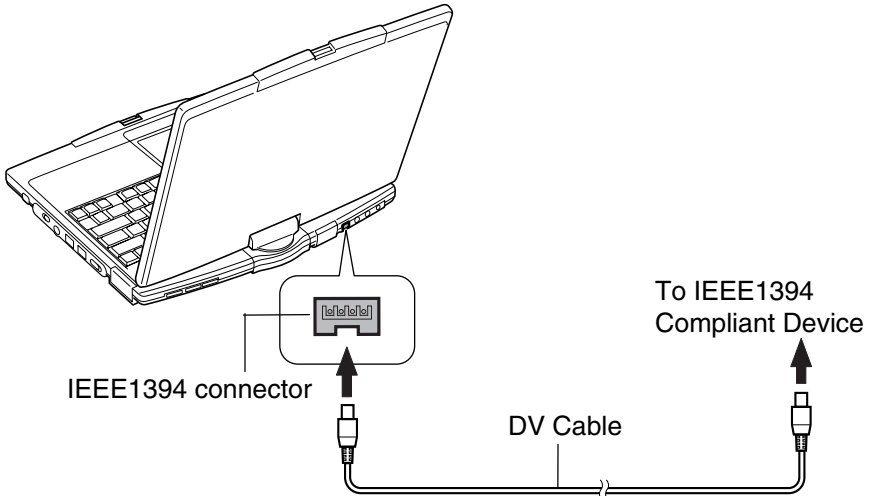

- *You need not turn off your computer before connecting the device.*
- *Be sure to read the manuals of the IEEE1394 device before connecting it to your computer.*

1. Connect the end of the DV cable into the IEEE1394 connector of your computer.
2. Connect the other end of the DV cable into the DV connector of the IEEE 1394 device.



3. Install the driver according to the instructions on the screen. Generally when you connect the device to your computer, the necessary driver will be installed automatically.
4. Start the appropriate application for handling your data.

Disconnecting IEEE1394 Device

1. Click the *Safely Remove Hardware* icon () on the taskbar. If you cannot find the icon, click  to show all kinds of icon. If the icon does not appear, go to Step 3.
2. If the name of your device appears, click *Safely remove xxxxx* (xxxxx is the name of your IEEE 1394 device.); then, *Safe To Remove Hardware* dialog appears.
3. Remove the DV cable from your computer.

Communication Functions

This chapter explains how to use the built-in modem, the wired LAN unit and the wireless LAN function.



- *When you use communication software:*
 - *Connect your computer to the AC power source.*
 - *Disable power management. (Refer to Disabling Power Management in Chapter 4.)*
 - *See also manual or online help of the software you are using.*
- *The communication speed may vary depending on the traffic, local telecommunications infrastructure, and ISP (Internet Service Provider) infrastructure.*

Built-in Modem

You can use the built-in modem for data transfer and fax communication.



- *To reduce the risk of fire, use only No. 26 AWG or larger telecommunication line cord.*
- *The built-in modem on your computer is designed only for regular analog telephone lines. The modem may be damaged when connected to a digital ISDN terminal or a digital PBX.*
- *Use TA (terminal adapter) to connect the built-in modem to a digital telephone line.*
- *If an unusual device is attached to the line you are connecting to, the modem may not function properly. Remove the device or contact the dealer of the device.*
- *Before connecting to a PBX, consult the PBX maintenance staff or its service company. If the electric characteristics of your PBX are different from those of a regular analog line, the modem will not function properly. If you connect the modem to a digital PBX, both the modem and the PBX may be damaged.*



- *Within the communications software you are using, set the COM port of the built-in modem to COM 3 if required.*
- *Before commencing with fax communication, it is recommended that you exit other application programs.*

Connecting Modem To Telephone Line

1. Turn off your computer.
2. Open the cover on the rear side of your computer.

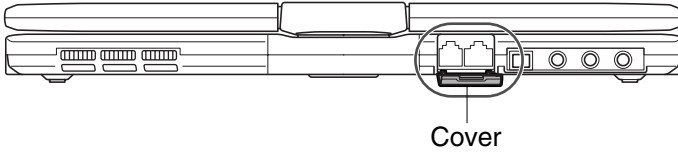

To avoid damaging the modem, close the cover when nothing is connected to the modem and LAN jacks.

3. Connect one end of the included modem cable to the modem jack.

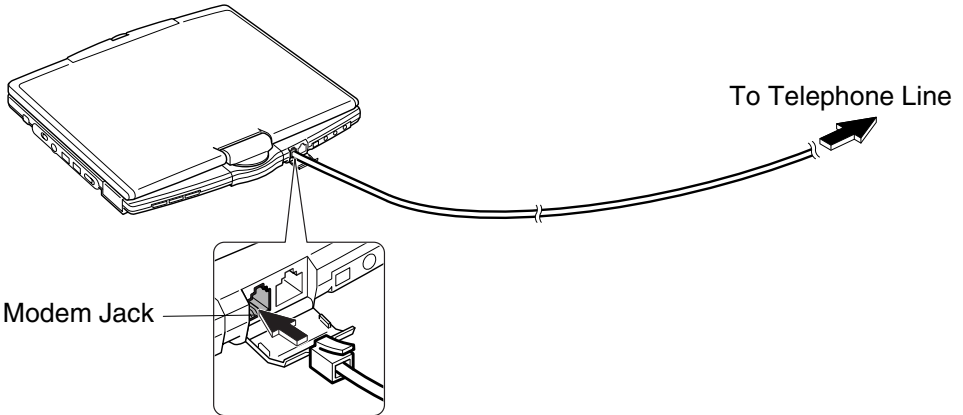

6



Be sure to insert the modem cable into the modem jack. Do not insert into the LAN jack. It may damage the LAN jack or the modem cable.

4. Connect the other end of the modem cable to the telephone line.
5. Turn on your computer.



Connect the modem to the telephone line directly. Do not use a distributor or alloter.

Configuring Modem

You may have already configured your modem during Windows setup process. Otherwise, make the necessary adjustments as shown below.

Modem Configuration

When you use the modem first time, you must type your location's information.

1. Click *start - Control Panel - Printers and Other Hardware*; then, *Phone and Modem Options*. If Classic view is selected, double-click *Phone and Modem Options* icon.
2. In *Location Information* dialog box, select your country, type your area code, etc., and select your dial type; then, click *OK*.

After the configuration, click or double-click *Phone and Modem Options* (icon) to open *Phone and Modem Options* dialog box and double-click the location name of *Locations* in *Dialing Rules* tab for the information you set above.

Clicking *New...* or *Edit...* allows you to make a new location or change the settings.

Internet Connection

Windows XP has a special Internet connection wizard to help you to connect to the Internet with ease.

1. Click *start - Control Panel - Network and Internet Connections*; then, *Network Connections*. If Classic view is selected, double-click *Network Connections* icon.
2. In *Network Connections* dialog box, click *Create a new connection* of *Network Tasks* section. The *New Connection Wizard* dialog box will appear.
3. Follow the instructions on the screen.

If you plan to connect into the Internet and dial an Internet Service Provider (ISP) through the modem, have your account information and dial-up number ready before you begin the wizard. Once you set your connection, you can see or edit the connection status by double-clicking the icon appearing on *Dial-up* of *Network Connections* dialog box.

LAN Unit

You can connect to a LAN (Local Area Network) with the 100 Base-TX/10 Base-T LAN units on your computer. To activate the LAN unit, perform the following steps.



Never insert any cables, but a LAN cable, which have different electric characteristics from those of the LAN cables. Otherwise, the LAN unit and the cables may be damaged.



Use a category 3 or a category 5 LAN cable when connecting to 10 BASE-T LAN, and the category 5 only when connecting to 100 BASE-TX LAN.

Connecting Your Computer To LAN

1. Turn off your computer.
2. Open the cover on the rear side of your computer.

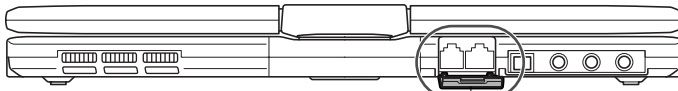

Cover

6



To avoid damaging the LAN unit, close the cover when nothing is connected to the modem and LAN jacks.

3. Connect one end of the LAN cable to the LAN jack and the other to the network hub.

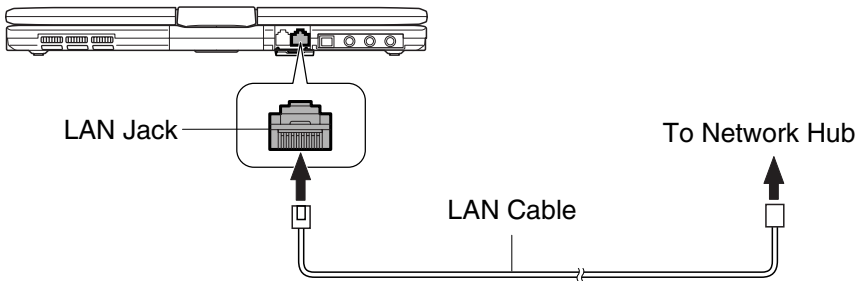



Confirm the cable to be inserted is a LAN cable. Do not insert the modem cable into the LAN jack. It will damage the modem cable and the LAN jack.



You can also directly communicate with another computer using a cross LAN cable.

4. Turn on your computer.

Configuring LAN Unit

1. Click *start - Control Panel*.
2. Click *Network and Internet Connections*; then, *Network Connections*. If Classic view is selected, double-click *Network Connections* icon.
3. Right-click *Local Area Connection*.
4. From the pop-up menu, click *Properties*.
5. In the *Local Area Connection Properties* dialog box, set the network setting according to the instruction of your network administrator.



Make sure to log on your computer as a member of the Computer administrators group. Otherwise, you cannot set or change some settings for the LAN unit.

If you cannot access the network,

1. Click *start - Control Panel*.
2. Click *Performance and Maintenance*; then, *System*. If Classic view is selected, double-click *System* icon.
3. Click *Hardware* tab; then, *Device Manager* button.
4. Double-click *Network adapters*, then, *Realtek RTL8139 xxxxx*.
5. Click *Advanced* tab, and select *Link Speed/Duplex Mode* in *Property* list and select an appropriate value in *Value* pull-down menu.
6. Click *OK* and close the *Device Manager* window.
7. Click *OK* and close the *Control Panel* window.

Configuring Network Settings

You can configure your network settings in various manners according to the network environments. This section provides one of them in the following environment.

- When connecting two computers, which do not have Internet connections, directly each other with a cross LAN cable.
- When the other computer is running on Windows XP
- When using the *Network Setup Wizard* for network configuration

Configuring Network Settings of Your Computer



Prior to configuring, be sure to connect two computers with a cross LAN cable.

1. Click *start – All Programs – Accessories – Communications – Network Setup Wizard*. The *Network Setup Wizard* dialog box will open.
2. Click *Next* twice.



When a message “The wizard found disconnected network hardware.” appears:

- *With Local Area Connection string displayed in Connections field, click Cancel to quit the wizard and confirm the other computer is powered on or the both computers are connected with a cross cable.*
- *Otherwise, check the box of Ignore disconnected network hardware and then, click Next.*

3. Select *Other* and click *Next*.
4. Select the third option, *This computer belongs to a network that does not have an Internet connection*, and click *Next*.
5. Select the second choice, *Let me choose the connections to my network*, and click *Next*.
6. Uncheck the boxes of *1394 Connection* and *Wireless Network Connection*.



Confirm only the box of Local Area Connection is checked.

7. Click *Next*.
8. Input *Computer description*, if necessary and *Computer name*, then, click *Next*.



The Computer name should be unique. Type a name that is different from that of the other computer.

9. Type a *Workgroup name* and click *Next*.



The Workgroup name should be same as that of the other computer.

10. Click *Next*. The network configuration will start.
11. Select the fourth option, *Just finish the wizard; I don't need to run the wizard on other computers*, and click *Next*.
12. Click *Finish*, then, *Yes*. Your computer will restart.

Change Your Computer Name or Workgroup Name

When you need to change your computer name or workgroup name, follow these instructions.

1. Click *start – My Computer*.
2. Click *View system information* in *System Tasks* field. *System Properties* dialog box will open.
3. Click *Computer Name* tab and *Change...* button. *Computer Name Changes* dialog box will appear.
4. Type the *Computer name* and the *Workgroup* in each field and then, click *OK*.
5. Click *OK* twice and *Yes*. Your computer will restart.

Sharing Files and Folders

You can share files and folders on each computer when they are permitted to be shared. With this function you can copy documents stored on your desktop computer to your notebook computer or display data on your computer and the other computer.

Sharing Files and Folders

This section provides how to share a folder. With these steps you can also share a drive.

1. Right-click a folder to be shared and click *Sharing and Security.... XXX Properties* dialog box will open. (XXX is the folder's name.)
2. Check the box of *Share this folder on the network*. Confirm the name typed in *Share name* field is the folder name to be shared.



When you have not used Network Setup Wizard or shared any folders or drives before, follow these instructions to enable file sharing.

1. *Click* If you understand the security risks but want to share files without running the wizard, click here *in* Network Sharing and Security *section*. Enable File Sharing *dialog box* will appear.
2. *Select* Just enable file sharing *and click* OK.
3. *Check the box of* Share this folder on the network *and type the folder name to be shared in* Share name *field*.

3. Click *OK*.



The icon of the shared folder will be added a sharing mark (👉).

6

Copying Shared File

1. Click *start – Control Panel*.
2. Click *Network and Internet Connections*; then, *Network Connections*. If Classic view is selected, double-click *Network Connections* icon.
3. Click *My Network Places* in *Other Places* field located on the left.
4. Click *View workgroup computers* in *Network Tasks* field. All the icons of computers belonging to the same workgroup will appear.
5. Double-click the icon of the other computer. The shared folder(s) will appear.
6. Double-click the shared folder. When a password is required, type it.
7. Drag and Drop the desired file to the desktop of your computer. The copied file is created on your computer.
8. Close the window.

Wireless LAN

Your computer has an integrated wireless LAN function compliant with IEEE 802.11b standard. You can access the network by the wireless LAN.



There are two kinds of wireless networks: a network using an access point and a peer-to-peer wireless network. You can connect your computer to a wired LAN or the Internet through an access point that is also compliant with IEEE 802.11b standard. Peer-to-peer wireless network consists of a number of computers each equipped with wireless networking interface. Each computer can communicate directly with other wireless enabled computers.



- *The range to give reliable performance and the quality of connection vary depending on the environment where you perform.*
- *Be sure not to cover the antennas with other objects such as your hands when communicating.*

To communicate through the wireless LAN, activate the integrated antennas. Refer to the next section.

Activating Antennas

You can enable/disable the antennas by pressing **Fn+F1** () key combination. When the antenna indicator () lights green, the antennas are enabled. When the indicator light is off, they are disabled.

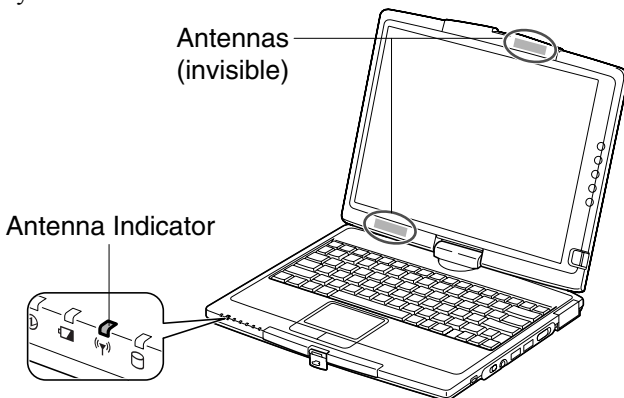

Connecting to Internet via Access Point

You can connect your computer to the Internet or a wired network via an access point supporting IEEE 802.11b. Refer to the manual of the access point or consult your network administrator if you are not sure.

Communicating with Other Computers



- *Confirm each computer is enabled for wireless LAN first.*
- *Make sure to log on your computer as a member of the Computer administrators group. Otherwise, you cannot set or change some settings for wireless LAN.*

1. Click *start – Control Panel*.
2. Click *Network and Internet Connections – Network Connections*. If Classic view is selected, double-click *Network Connections*.
3. Select *Wireless Network Connection*; then, click *Change settings of this connection* of *Network Tasks*.
4. Double-click *Internet Protocol (TCP/IP)* in *This connection uses the following items*.
5. In *Internet Protocol (TCP/IP) Properties* dialog box, select *Use the following IP address* and set a unique *IP address* to *192.168.1.2* through *192.168.1.254* and the *Subnet mask* to *255.255.255.0*; then, click *OK*.



- *The IP address of each computer should be unique.*
- *The Default gateway can be blank.*

6. Click *Wireless Networks* tab; then, *Advanced* button in the lower right of the dialog box. *Advanced* dialog box appears.
7. Select *Computer-to-computer (ad hoc) networks only*; then, click *Close* button.
8. Click *Add...* button in *Preferred networks* of *Wireless Network Connection Properties* dialog box.
9. Type a name of the network in *Network name (SSID)* field of *Wireless Network Properties* dialog box.



Confirm your computer and other computers are connecting to the same network.



10. Click *OK* twice; then, close the *Control Panel* window.
11. Configure the network by setting the name of your computer and workgroup.



To communicate with other wireless enabled computers, set your computer name and the workgroup name. Your computer name should be unique and the workgroup name should be same as others.

Confirming Status of Wireless Connection

Before performing the following instructions, confirm the devices that you want to communicate with are enabled for wireless LAN.

1. Click *Wireless Network Connection* icon ( or ) on the taskbar. If you cannot find the icon click  to show all kinds of icon. *Wireless Network Connection* dialog box appears. If *Wireless Network Connection Status* dialog box appears, go to Step 7.
2. Select a network you want to access in *Available wireless networks* in *Wireless Network Connection* dialog box. If the network requires the *Network key* entered, go to Step 4. If it is not set *Network key*, the caution message appears.



*When the network name you want to access does not appear, click *Advanced* tab; then, *Refresh* button of *Available networks* in *Wireless Network Connection Properties* dialog box; then, click *OK*.*

3. When you agree with the message, check the box of *Allow me to connect...* and go to Step 5.
4. Type the required *Network key*. (Refer to *Connecting the WEP configured network* section.)
5. Click *Connect* button.
6. Click *Wireless Network Connection* icon () on the taskbar.
7. In *Wireless Network Connection Status* dialog box, confirm your connection status.



- *The number of green signals () shows the connection quality. The more signals light on, the better quality is given to your computer.*
- *When the quality of connection is poor, adjust the distance between your computer and other devices or the access point you are communicating with and/or the facing direction of your computer.*

Connecting to WEP Configured Network

Wireless communication has security issues. Some networks are configured with WEP (Wired Equivalent Privacy) keys or encryption keys to protect the transmitted data. To connect into the WEP configured network, follow the steps below.

1. Right-click *Wireless Network Connection* icon () on the taskbar and click *View Available Wireless Networks*.
2. Select the network you want to connect in *Available wireless networks* of *Wireless Network Connection* dialog box.
3. Type its encryption key in *Network key* field, type it again to confirm and click *Connect* button.



- *When you select a network that is not configured for encryption settings in the step 2, the caution message appears. If you agree to connect to the unsecured network, check the box of Allow me to connect to the selected wireless network, even though it is not secure.*
- *When the key index of your computer is different from that of the network, you cannot access the network. Set the same key index with the following steps. Note that some access points have the key index options 0 through 3. Refer to the table on the next page for matching.*

1. *Open the Wireless Network Connection Properties dialog box. (Refer to the steps in Communicating with Other Computer section.)*
2. *Click Wireless Networks tab, select the network you want to access in Preferred networks section and click Properties button.*
3. *Confirm the box of Data encryption (WEP enabled) is checked, uncheck the box of The key is provided for me automatically and set the key index.*

Key index matching table

Access Point 1	Access Point 2	Your Computer
1	0	1
2	1	2
3	2	3
4	3	4

(ex. When your access point type is “Access Point 2” and its key index is set to 0, set 1 for your computer.)

Network Setup Utility

With the Network Setup Utility, you can set up your specific network settings adjusted for your environments such as work, home, etc. and select the appropriate one to the environment. You can also change the network settings.



- *Not every setting item can be stored.*
- *The Network Setup Utility may not be compliant with all network environments.*

Loading Network Settings

To set your specific network settings, confirm that your computer is connected into the network and has the proper settings for your current environment and follow the instructions below.

1. Click *start – All Programs – SHARP Network Setup Utility – SHARP Network Setup Utility*.
2. Click *OK*.
3. Click *Set*, select *SHARP icon* or *Windows icon*, then, click *Select icon* button.
4. Select an icon and click *OK*. Type a network name, then, click *OK*. The selected icon appears in the *Network Setup Utility* window.



- *It takes a moment to load the network settings.*
- *You can load up to twenty networks.*

Switching Network

To switch the network set above, confirm your computer is ready to connect into the network and follow the instructions below.

1. Click *start – All Programs – SHARP Network Setup Utility – SHARP Network Setup Utility*.
2. Click *OK*.
3. Select the appropriate network icon in the *Network Setup Utility* window.
4. Click *OK*.



- *Make sure your computer is connected to the proper environment.*
- *If your hardware or software configuration has been changed, you may not be able to switch to the network properly. In this case, you may need to reconfigure the settings.*

Changing Network Settings

To change the loaded network settings, right-click on the icon you want to change the settings in the *Network Setup Utility* window and click *Edit settings* in the pop-up menu. Then, edit the settings.

Deleting Network

To delete the loaded network settings, right-click on the icon you want to delete in the *Network Setup Utility* window and click *Delete setting* in the pop-up menu. Then, click *OK*.

Setup Utility

This chapter describes how to run the Setup Utility to change settings on your computer.

Running Setup Utility

With the Setup Utility, you can customize the system configuration information, such as time and date, port assignments, or passwords. The information you have specified is saved in a special area called CMOS RAM, which the system reads every time you turn on your computer. Your computer is shipped from the factory with the appropriate setting of the Setup Utility. Leave it as default in normal use.

Contents of the Setup Utility

The Setup Utility consists of five menu pages, as follows:

- Main: Configures basic setting
- Advanced: Configures device interface
- Security: Sets Passwords
- Boot: Sets where the system boots from
- Exit: Exits the Setup Utility or returns to the default values

Entering and Exiting the Setup Utility

1. Turn on the computer.
2. When *Press F2 for System Utilities* appears, press **F2**.
3. Change to the desired settings. Refer to the next section.
4. Select *Exit* menu; then, press **Enter**.
5. Select one of the exit methods, and press **Enter**.
6. Confirm the message and press **Enter** again. The system restarts.



When the Setup Utility is opened, power management does not work. Do not close the display cover.

Changing the setting of the Setup Utility

To change the settings:

1. Use → or ← key to select the menu.
2. Use ↑ or ↓ key to select the item.

Minus or **Space** key : Changes the value.

In the item with ► mark, press **Enter** to open a sub menu. Press **Esc** to close the sub menu and return to the previous menu.

For date and time, press **Enter** on the item to select the value you want to change; then, use minus key or space bar to change the value.

3. Close the Setup Utility by following the steps above.

Main Menu

System Time defines the system time, using the format *hour:minute:second* (24-hour format). Use **Tab** key to move the cursor, and minus key or space bar to change numerals.

System Date defines the system date, using the format *month/day/year*. Use **Tab** key to move the cursor, and minus key or space bar to change numerals.

Hard Disk Type shows the type of the hard disk of your computer. Press **Enter** to show the details.

Internal NumLock defines whether the numlock keys of the built-in keyboard are always disabled or not. (Num lock indicator will turn when **Fn+NumLk** are pressed regardless of this setting. An external keyboard will be numlocked if connected.)

C3 State defines whether the system reduces power consumption while the CPU is idling.

USB Key/Mouse Emulation defines whether USB devices (a keyboard or a mouse) can be used in DOS mode.

Quick Boot defines whether the system skips the check of the internal memory while booting, to shorten the boot time

Quiet Boot defines whether the SHARP logo appears on the screen while booting.

Video RAM Size shows the minimum size of the video memory on Windows. The volume of the video memory varies automatically by the integrated video controller in Windows environment.

CPU Information shows the information on the CPU.

System Memory shows the volume of the conventional memory used in MS-DOS. Always set to 640KB.

Extended Memory shows the volume of the extended memory more than 1MB.

BIOS Version shows the BIOS version of the system.

EC/KBC Version shows the EC or keyboard controller version of the system.

Advanced Menu

Tablet Device sets the tablet pen, selecting the base I/O address. *Enabled* means that you can set the item by yourself. *Auto* means that the item is automatically assigned. *Disabled* means that you cannot use the tablet pen.

Programmable Button Device enables or disables the programmable buttons.

Internal Pointing Device enables or disables the built-in glide pad.

System Beep controls the volume level of the beep before Windows starts.

Resolution Expansion defines whether the Setup Utility screen is expanded when the resolution is 640x480 or 800x600. *Enabled* means that the screen is expanded.

Plug&Play O/S enables or disables plug & play function.

PCI Configuration normally has to be as default.

Security Menu

Set Supervisor Password defines the supervisor password (up to eight characters). See the next section about the supervisor password.

Set User Password defines the user password (up to eight characters). See the next section about the user password.



If you lose your password, you will be unable to access the computer or change the configuration. Make sure to select a password you will never forget, or write it down and protect it in a secure place. Otherwise, you will have to contact your dealer for assistance.

Hard Disk boot Sector defines whether the boot sector of the hard disk is write-protected. When formatting the hard disk or reinstalling software, set to *Normal*.

Password on boot defines whether you have to type the password for booting the computer.

Device Configuration enables or disables built-in devices such as USB, audio system, modem, LAN, PC card, IEEE1394 and Wireless LAN.

Supervisor and User Password

Setting a password will protect your computer against unauthorized access. Once a password is set, the system requires the password when entering to the Setup Utility. And if *Password on boot* is enabled, the system will require a password when the computer is turned on.



If you enter a wrong password three times, the message System Disabled appears. Shut down your computer with the power switch and after 10 seconds, slide it to turn on your computer again.

Your computer supports two different levels of password security: Supervisor password and User password. You cannot set a user password unless you have set a supervisor password. If you share the computer with others, we recommend that you set both the supervisor and the user password, and let others know the user password only.

If you type the user password when you enter the Setup Utility, you can change *System Time* and *System Date* of the *Main* menu, *Resolution Expansion* of the *Advanced* menu and *Set User Password* of the *Security* menu only.

Setting Password

1. In the *Security* menu of the Setup Utility, select *Set Supervisor Password* or *Set User Password* and press **Enter**.
2. Type your password (up to eight characters), and press **Enter**.
3. Type the same password again, and press **Enter** twice.
4. Select *Exit* menu and confirm *Exit Saving Changes* is highlighted; then press **Enter**.
5. Confirm *Yes* is highlighted and press **Enter**. The system restarts.

Changing Password

1. In the *Security* menu of the Setup Utility, select *Set Supervisor Password* or *Set User Password* and press **Enter**.
2. Type your current password, and press **Enter**.
3. Type your new password, and press **Enter**.
4. Type your new password again, and press **Enter** twice.

5. Select *Exit* menu and confirm *Exit Saving Changes* is highlighted; then press **Enter**.
6. Confirm *Yes* is highlighted and press **Enter**. The system restarts.

Deleting Password

1. In the Security menu of the Setup Utility, select *Set Supervisor Password* or *Set User Password* and press **Enter**.
2. Type your current password, and press **Enter**.
3. Without typing any characters, press **Enter**.
4. Press **Enter** twice.
5. Select *Exit* menu and confirm *Exit Saving Changes* is highlighted; then press **Enter**.
6. Confirm *Yes* is highlighted and press **Enter**. The system restarts.

Boot Menu

Boot Sequence specifies where the system boots. Press **Enter** to open the sub menu. The system boots from the drive at the top of the list. If the system cannot find the drive, it will boot from the second one; then, third one; then fourth one. Use arrow keys to select the drive you want to move; then, use minus key or space bar to move it up and down.

USB FDD/CD enables or disables the USB floppy disk drive and the USB optical drive.

LAN Boot defines whether the system boots from other server via the LAN unit of the computer.

Exit Menu

Exit Saving Changes saves the settings you have changed and exits the Setup Utility.

Exit Discarding Changes exits the Setup Utility without saving the settings you have changed.

Load Setup Defaults returns the values of all items to the default. To exit, select one of the above items.

Discard Changes returns the values of all items to the values you last saved. To exit, select one of the above two items.

Save Changes saves the settings you have changed. To exit, select one of the above two items.

Appendixes

The appendixes contain additional information on the use and care of your computer.

Memory Module

You can install a memory module into your computer and upgrade its memory size. See the provided specification sheet for the default and maximum memory size of your computer. For available memory modules, contact your local dealer.

Installing Memory Module



- *Do not handle the memory module in the location where static electricity is easily generated such as on the carpet.*
 - *Before installing the memory module, carefully discharge static electricity from your body by touching an unpainted metal area.*
 - *Avoid touching the integrated circuits on a memory module. Handle all components by the edges.*
 - *Keep the memory module in the anti-static wrapping until you are ready to install it.*
-

1. Turn off your computer, and disconnect the AC adapter and remove the battery pack and peripheral devices. See Chapter 4 for removing the battery.



- *Make sure to turn off your computer and remove the AC adapter. Otherwise you may receive an electrical shock.*
 - *After a long usage of your computer, the temperature inside your computer may be hot. Wait until it becomes cool.*
-

2. Close the display, the LCD display side down, and turn your computer over on a stable surface. See Chapter 1 for closing the display.



- *Never close the display with the LCD side up.*
 - *Be sure to lock the display with the hook.*
-

3. Loosen two screws and remove the memory slot cover.

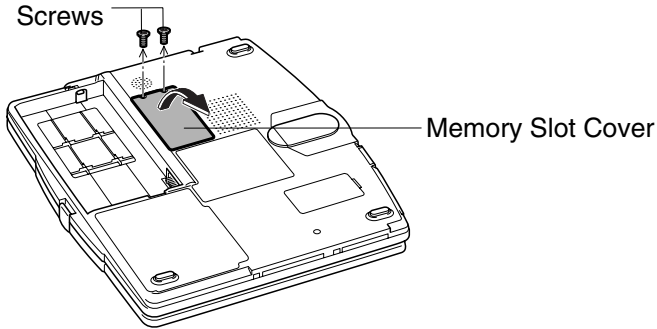

4. Turn over the sheet and align the memory module as shown below, matching the notched part of the module with the projected part of the memory socket of your computer.

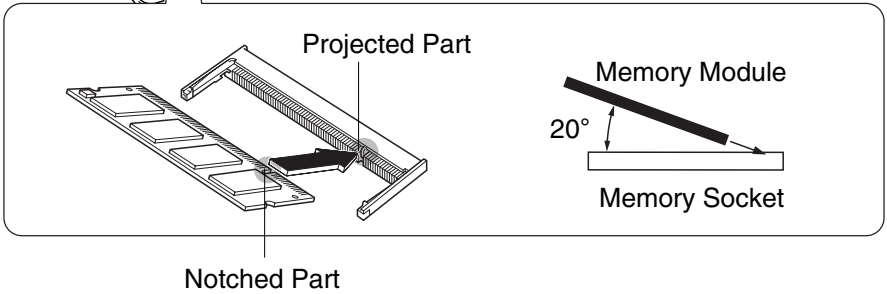
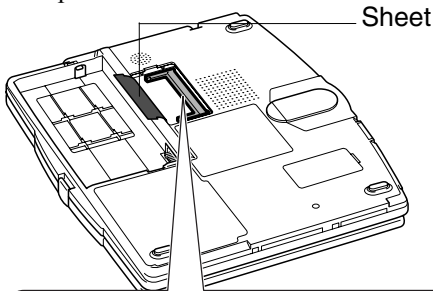

5. Press the memory module slowly to place it into the memory socket, matching the notched parts of the module with the projected parts of the socket, until you hear the clicking sound.

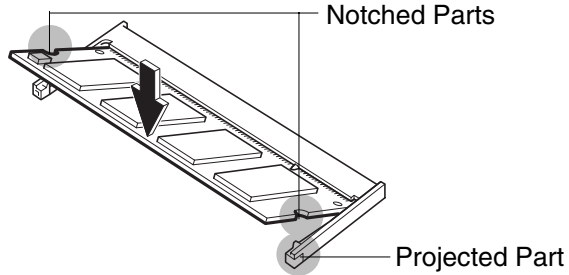

6. Replace the sheet and memory slot cover, matching the projected parts of the cover with the notched parts of your computer.

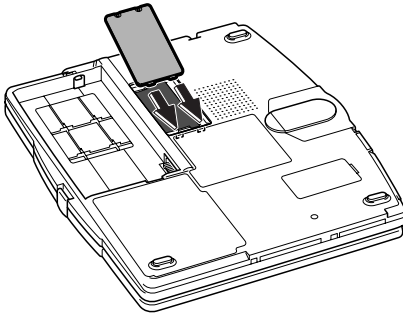

7. Tighten the screws.

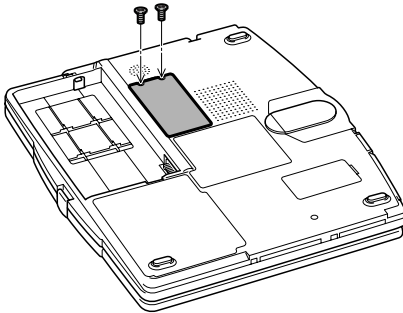

8. Replace the battery pack and connect the AC adapter. Refer to Chapter 4 for installing the battery pack.
9. Open the display cover; turn on your computer and check the memory size; by clicking *start – My Computer – View system information* of *System Tasks*. Your memory size appears at the bottom of the sentence in *General* tab. Share video memory size will not be included with the value.

Uninstalling Memory Module

1. Follow steps 1-3 of *Installing Memory Module*.
2. Turn over the sheet and slightly bend both latches outwards until the memory module is released.

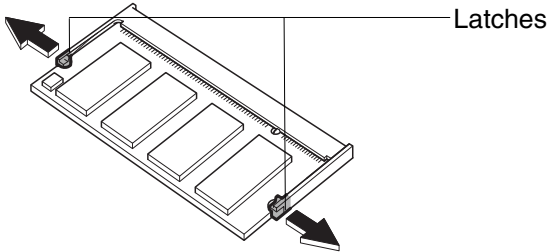

3. Remove the memory module and follow steps 6-9 of *Installing Memory Module*.

Maintenance and Care

This appendix provides you with information on how to maintain your computer in excellent working condition.

Using Security Cable

You can connect a security cable into the security slot on the right side of your computer to prevent theft.

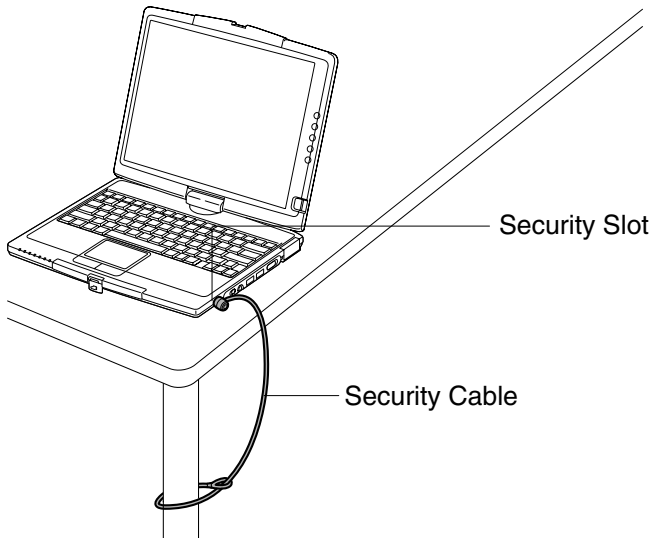

Cleaning Your Computer

Cabinet

Apply a small amount of mild cleaning solution to a dry, lint-free cloth and wipe the cabinet with the cloth.



- *Never clean your computer while it is powered on.*
 - *Do not use alcohol, benzene, thinner or other strong chemical agents that may damage the cabinet.*
-

Screen

The surface of the screen may become smeared and accumulate dust during use. Avoid touching the screen with your fingers when using the system. Gently wipe the surface of the screen with a soft cloth that has been dipped in a mild detergent solution and squeezed dry.

Glide Pad

Wipe the glide pad with a soft, dry cloth.

Ventilation Openings

Dust on the ventilation openings may cause overheating of your computer. Wipe the ventilation openings with a soft, dry cloth.

Cleaning Your Tablet Pen

Use either a silicone cloth or if not available a dry cloth for cleaning. Do not use volatile liquids such as alcohol, thinner, or benzene etc.

Traveling With Your Computer

Your computer is designed for portability. For safety and convenience when traveling, please follow these guidelines.

- Before traveling, back up your data on floppy disks or other external media.
- Do not travel with any peripheral devices connected such as an optional external floppy disk drive unit or the external optical drive.
- Do not travel with a protruding PC card such as a wireless networking card inserted into the PC card slot.
- Do not carry your computer powered on. This may result in loss of data and/or damage to the hard disk drive.

- Make sure the display cover is closed before traveling. Otherwise, the cover may be opened unawares, and the display or the keyboard will be damaged.
- Make sure your computer is not in tablet mode. Otherwise the display will be damaged.
- If you carry your computer in a bag, try to avoid unnecessary pressure, caused by the stuff of the bag, to your computer.
- Disconnect the AC adapter from your computer.
- Fully charge the standard battery pack and bring the AC adapter and the AC power cord.
- Avoid sudden shocks or extreme vibration.

Re-installation Instructions

To recover your hard disk, you will use PowerQuest®EasyRestore™. Before starting re-installation, read the following End User License Agreement first.

PowerQuest(R) EasyRestore (TM) End User License Agreement

IMPORTANT: Read this before using your copy of PowerQuest software.

This document is a legal agreement between you, the "end user," and PowerQuest Corporation. Use of the software indicates your acceptance of these terms. As used in this License Agreement, the term "Software" means the EasyRestore software included on the CD provided with this License Agreement.

1. **PROPRIETARY RIGHTS.** The Software is a proprietary product of PowerQuest Corporation ("PowerQuest") or its licensors and is protected under U.S. copyright laws and international treaty provisions. Ownership of the Software and all copies, modifications, and merged portions thereof shall at all times remain with PowerQuest or its licensors.
2. **GRANT OF LICENSE.** The Software is being licensed to you, which means you have the right to use the Software only in accordance with this License Agreement. The Software contains pre-installed software for disaster recovery purposes. The Software is only authorized for distribution together with a specific computer. This License authorizes you to use the Software for disaster recovery purposes only, to restore the hard disk image contained on the CD to the computer with which the CD and Software were originally shipped.
3. **NONPERMITTED USES.** Without the express permission of PowerQuest, you may not (a) use, copy, modify, alter, or transfer, electronically or otherwise, the Software or documentation except as expressly permitted in this License Agreement, or (b) translate, reverse program, disassemble, decompile, or otherwise reverse engineer the Software.
4. **TECHNICAL SUPPORT.** PowerQuest is NOT responsible to provide technical support. Any and all technical support questions, regarding the Software, should be referred to the place of purchase.
5. **U.S. GOVERNMENT RESTRICTED RIGHTS.** If you are acquiring the Software on behalf of any unit or agency of the United States Government, the following provision applies: It is acknowledged that the Software and the documentation were developed at private expense and that no part is in the public domain and that the Software and documentation are provided with RESTRICTED RIGHTS. Use, duplication, or disclosure by the Government is subject to restrictions as set forth in subparagraph (c)(1)(ii) of the Rights in Technical Data and Computer Software clause at DFARS 252.227-7013 or subparagraphs (c)(1) and (2) of

the Commercial Computer Software-Restricted Rights at 48 CFR 52.227-19, as applicable.
Contractor/manufacturer is PowerQuest Corporation/P.O. Box 1911/Orem, UT 84059.

6. NO WARRANTY. The Software is being provided to you AS IS. PowerQuest does not warrant the Software to end users. If the Software fails to perform substantially in accordance with the documentation provided to your hardware supplier, PowerQuest will repair or replace the copy of the Software provided to your hardware supplier and will authorize your hardware supplier to provide such repaired or replaced Software to you without charge.

7. LIMITATION OF LIABILITY. NEITHER POWERQUEST NOR ITS SUPPLIERS SHALL IN ANY EVENT BE LIABLE FOR ANY DAMAGES WHATSOEVER ARISING OUT OF OR RELATED TO THE USE OF OR INABILITY TO USE THE SOFTWARE, INCLUDING BUT NOT LIMITED TO DIRECT, INDIRECT, SPECIAL, INCIDENTAL, OR CONSEQUENTIAL DAMAGES, AND DAMAGES FOR LOSS OF BUSINESS PROFITS, BUSINESS INTERRUPTION, LOSS OF BUSINESS INFORMATION, OR OTHER PECUNIARY LOSS, EVEN IF POWERQUEST CORPORATION HAS BEEN ADVISED OF THE POSSIBILITY OF SUCH DAMAGES, WHETHER SUCH LIABILITY IS BASED ON CONTRACT, TORT, WARRANTY, OR ANY OTHER LEGAL OR EQUITABLE GROUNDS. BECAUSE SOME STATES DO NOT ALLOW THE EXCLUSION OR LIMITATION OF LIABILITY FOR CONSEQUENTIAL OR INCIDENTAL DAMAGES, THE ABOVE LIMITATION MAY NOT APPLY TO YOU.

8. NO WAIVER. Any failure by either party to this agreement to enforce a specific part of the agreement in a specific situation is not a waiver of rights under the agreement. The party may still enforce the rest of the agreement in that situation and may still enforce some or all of the agreement in other situations.

9. This License Agreement constitutes the entire agreement between you and PowerQuest pertaining to its subject matter. This License Agreement is governed by the laws of the State of Utah. Any litigation arising from this license will be pursued only in the state or federal courts located in the State of Utah.

Copyright 1994-2003, PowerQuest Corporation. All rights reserved. U.S. Patents 5,675,769; 5,706,472; and 5,930,831; other patents pending in the U.S.A. and elsewhere. PowerQuest is a registered trademark and EasyRestore is a trademark of PowerQuest Corporation.

Recovery Way

You can format the hard disk and re-install the preinstalled software and set the status of your computer to the same configuration as you used for the first time. There are two ways to recover the hard disk drive(s) of your computer: via hard disk and via recovery CDs. The former saves your time, while the latter secures the re-installation data from potential loss or corruption. The later section describes the specific steps for each way.



Before you recover via recovery CDs, you need to write the recovery data already installed on your computer onto blank CD-R discs. (Refer to the later section.) You are required to create the recovery CDs only once.

Preparation For Re-installation

The following items are necessary for re-installation.

Via Hard Disk

- Operation Manual

Via Recovery CD

When you recover first time, you need the following items to create recovery CDs.

- Operation Manual
- External CD-R drive unit (LITEON LSC-24081MX USB Drive (Combo) recommended)
- Three blank 650MB or 700MB CD-R discs for creating recovery CD

When you recover after preparing the recovery CDs:

- Operation Manual
- External CD-R/RW drive unit (LITEON LSC-24081MX USB Drive (Combo) recommended) or CD-ROM drive unit (SHARP CE-CD05 recommended)
- The created recovery CDs



When recovering with the recovery CDs, use one of the recommended drive units (LITEON LSC-24081MX USB Drive (Combo) or SHARP CE-CD05). Otherwise, you may not be able to recover your system properly.

Backing Up Data

Before formatting the hard disk, you should back up your data. For details on how to back up your data, see the *Windows Help and Support*.

Selecting Way To Recover Your System

Your computer has two drives (C: and D:) when it was shipped from the factory. You can select the way to recover your system.

- *Recovers C: drive only. (Recommended)*
This process will format C: drive only and recover C: drive to the same status as shipped from the factory. Nothing will be performed to D: drive. The volume of the drives will not be changed and will keep current one.
- *Recovers both C: and D: drive.*
This process will format both C: and D: drives, and contents of the hard disk will be restored to its original state in C: drive. The volume of the drives will be back to the same as you used for the first time. This choice will not allow you to recover your system from the hard disk once the recovery process is completed.
- *Formats hard disk and creates new partition.*
This process will format whole hard disk drive and create new partition. You can select the volume of C: and D: drives. The contents of the hard disk will be restored to its original state in C: drive. This choice will not allow you to recover your system from the hard disk once the recovery process is completed.

Formatting Drives And Re-installing Windows

Via Hard Disk

With this way, recovery will come from data already installed on your computer rather than from external media such as CD. It will save your time but if the recovery data is lost or corrupted, there is no way to recover your system.



Note that if there is any chance of the data loss or corruption, you cannot recover your hard disk.



The tablet pen is not available for the hard disk recovery procedure.

1. Make sure your computer is turned off.
2. If any peripheral devices are connected to your computer, disconnect them.

3. Connect the AC adapter.



Be sure to connect the AC adapter. If the battery power becomes significantly low, the installation process will be canceled.

4. Turn on your computer. When the message *Press F2 for System Utilities* appears on the bottom left of the screen, press **F2**. Then, the Setup Utility will open.
5. In the *Exit* menu, select *Load Setup Defaults*; then, press **Enter** twice.
6. In the *Exit* menu, confirm *Exit Saving Changes* is highlighted and press **Enter** twice.
7. The system will restart. When the message *Press F10 to Recover* appears on the upper left of the screen, press **F10**.
8. Read the message on the screen, and select the way to recover your system; then, press **Enter**. If you selected *Formats hard disk and creates new partition*, go to the next step. Otherwise, go to Step 10.
9. Select the volume of C: drive and press **Enter**.
10. Read the message and select *Continue*; then, press **Enter**. The formatting and re-installation will start.



- *Although the pointer may be shown on the screen, never touch the keyboard or the mouse during recovery except when the message prompts you to. If you touch them, the re-installation will be canceled.*
 - *Also never operate the tablet pen during recovery process.*
-

11. When the re-installation process is completed, the system will restart automatically.
12. Set up Windows XP by following the on-screen instructions. When you complete the Windows setup, make sure to set date and time.

Via Recovery CD

Recovery CD does not come with your computer. First, you need to replicate the recovery data by copying onto CDs and then, recover the system with them.



- *You will have only one duplicate copy. Once you successfully burn the data onto CDs, you do not have to do it anymore.*
- *Even if you cancel the CD burning process, you can create recovery CDs by following the entire burning steps from the first step.*
- *You can recover your system via hard disk after succeeding in creating the recovery CDs.*
- *You need an external optical drive for CD recovery. Read its manual carefully before using the drive.*
- *The CD creating time varies depending on your optical drive and selected burning speed.*

Creating Recovery CD

To create the recovery CD, you will use *Bootable CD Creator*. Read the following End User License Agreement first.

Enterprise Corporation International Software License Agreement

This End-User License Agreement (“the Agreement”) is a legal agreement between you, the “end user,” and Enterprise Corporation International (“ECI”) for the ECI product, which includes a computer program (Bootable CD Creator), data, and manuals (“SOFTWARE PRODUCT”). Ownership of the SOFTWARE PRODUCT shall at all times remain with ECI. The SOFTWARE PRODUCT and accompanying documentation are licensed to you, which means you have the non-transferable and non-proprietary right to use the SOFTWARE PRODUCT in accordance with this Agreement. The SOFTWARE PRODUCT and any accompanying documentation are proprietary products of ECI or its licensors and are protected by United States copyright laws and international copyright treaties. Use of the enclosed software indicates your acceptance of these terms.

Intended Purpose:

The SOFTWARE PRODUCT is installed on and shipped with a computer manufactured by Sharp. You may use the SOFTWARE PRODUCT only for making a Bootable CD from the recovery image file that is pre-installed on the hard disk. You may use the SOFTWARE PRODUCT only on the computer with which this SOFTWARE PRODUCT is provided.

You may not:

1. Copy the SOFTWARE PRODUCT, in whole or in part, to another media except for installation.

2. Share the license for the SOFTWARE PRODUCT or use it concurrently on different computers.
3. Alter, transfer or sell (including e-sales through the Internet) the SOFTWARE PRODUCT and/or its copy to a third party, in whole or in part.
4. Delete or change the notice of copyright contained in the SOFTWARE PRODUCT.
5. Reverse engineer, disassemble, or decompile the SOFTWARE PRODUCT.
6. Create source code for the SOFTWARE PRODUCT from the object code.
7. Use any portion of the SOFTWARE PRODUCT within any other program.
8. Install or run the SOFTWARE PRODUCT over the Internet for use by multiple users.

Term: This Agreement is effective from your date of purchase or the date you opened the package and shall remain in force until terminated. Upon termination of this Agreement, you must destroy all copies of the SOFTWARE PRODUCT and all accompanying documents. ECI may terminate this Agreement if you fail to comply with its terms and conditions.

Limited Warranty: ECI warrants that the SOFTWARE PRODUCT will perform substantially in accordance with the accompanying documentation. The warranties set out in this agreement are in lieu of and exclude all other warranties not expressly set forth herein, whether express or implied, including but not limited to any warranties of merchantability, fitness for a particular purpose, or warranties arising from usage of trade or course of dealing.

Limitation of Liability: In no event shall ECI or Sharp be liable for any special, incidental, indirect, or consequential damages, or for damages for loss of business profits, business interruption, loss of business information, or other pecuniary loss, even if ECI or Sharp has been advised of the possibility of such damages.



Before creating the recovery CD, follow the instructions below:

- *Prepare three blank 650MB or 700MB CD-R discs.*
- *Connect the AC adapter. If the battery is discharged, the operation will stop and fail.*
- *Disable the power management. See Power Management section in Chapter 4.*
- *Close all of the unnecessary or the automatic start-up applications.*
- *Disable the wireless LAN antennas. See Wireless LAN section in Chapter 6.*
- *Disable the screen saver. See Changing Wallpaper and Setting Screen Saver section in Chapter 2.*

1. Connect the AC adapters to your computer and the external optical drive unit.



Be sure to connect the AC adapter. If the battery is completely discharged, the burning CD process will be canceled.

2. Insert a blank CD-R onto the external CD drive unit. (If you see a dialog box or window, close it.)
3. Click *start – All Programs – Create Product Recovery CD-ROM*.
4. In the *Bootable CD Creator SE1.0* window, select the appropriate speed from the *speed* pull-down menu, then, click *Create Recovery CD*.
5. Read the message on the screen and then, click *Yes*, then, *OK*. The burning process will start.



Never touch the keyboard, the mouse or the screen during burning process except when the message prompts you to. If you touch them, the burning process may be canceled.

6. Replace the CD-R by following the instructions on the screen. Assign names to each CD-R in the order of burning so that you will set them in correct order when recovering.



- *Never use the hard-tip materials to write on the CD-R for labeling.*
 - *Do not write on the non-label side. Data is read from the non-label side. Do not mark this surface.*
-



If a window or dialog box opens, close it.

7. When you see the message *CD creation complete* on the screen, click *OK*, then, *Close*.
8. Click *Yes* and remove the CD-R from the optical drive.
9. Restart your computer.



- *Store the burned discs in a secure place.*
 - *Keep your discs away from direct sunlight, heat and excessive moisture.*
-

10. Remove the external optical drive if you don't use it.



When you disconnect the external optical drive, you need to stop the device. Follow the instructions on USB Device section of Chapter 5.

Recovering with Recovery CD



- *When you format entire of the hard disk drive (both C: and D: drives), the recovery data installed in it will be eliminated. Therefore you will not be able to recovery your system via hard disk.*
 - *Be sure to use one of the recommended drive units (LITEON LSC-24081MX USB Drive (Combo) or SHARP CE-CD05).*
-

1. Make sure your computer is turned off.
2. If any peripheral devices are connected to your computer, disconnect them.
3. Connect an external optical drive unit.
4. Connect the AC adapters to your computer and the external CD drive unit; then, turn on your computer.



Be sure to connect the AC adapter. If the battery is completely discharged, the installation process will be canceled.

5. When the message *Press F2 for System Utilities* appears, press **F2**. The Setup Utility opens.
6. Insert the Recovery CD disc 1 into the optical drive.



Always hold the CDs by the edges. Fingerprints, dirt or water on the CDs cause improper tracking. If a CD is dirty or does not work properly, clean it with a soft, dry cloth, wiping straight out from the center, along the radius.

7. In the *Exit* menu, select *Load Setup Defaults*; then, press **Enter** twice.
8. In *Boot Sequence* of the *Boot* menu, set *CD-ROM Drive* to the top of the list; then, press **ESC**.
9. In *Advanced* menu, select *Plug & Play O/S* and press **Enter**. The sub menu will open.

10. Select *No* and press **Enter**.
11. In the *Exit* menu, confirm *Exit Saving Changes* is highlighted and press **Enter** twice.
12. Select your optical drive from the options on the screen, then, press **Enter**.
13. Read the message on the screen, and select the way to recover your system; then, press **Enter**. If you select *Formats hard disk and creates new partition*, go to the next step. Otherwise, go to Step 15.



When you select Recovers both C: and D: drive or Formats hard disk and creates new partition, the recovery process will delete the recovery data installed in the hard disk. Therefore you will not be able to recover your system from the hard disk.

14. Select the volume of C: drive and press **Enter**.
15. Read the message and select *Continue*; then, press **Enter**. Follow the on-screen instructions for replacing the recovery CDs.



Although the pointer may be shown on the screen, never touch the keyboard, the mouse or the screen during recovery except when the message prompts you to. If you touch them, the re-installation will be canceled.

16. After the recovery process completed, the system will start automatically. When the message *Press F2 for System Utilities* appears, press **F2**. The Setup Utility will open.
17. In the *Exit* menu, select *Load Setup Defaults*; then, press **Enter** twice.
18. In the *Exit* menu, confirm *Exit Saving Changes* is highlighted and press **Enter** twice. The system will restart.
19. Set up Windows, following the instructions on the screen. Make sure to set date and time.
20. Remove the external optical drive if you don't use it.



When you disconnect the external optical drive, you need to stop the device. Follow the instructions on USB Device section of Chapter 5.

Troubleshooting

This chapter describes how to troubleshoot computer problems.

Common Problems

Problems with your computer can be caused by something as minor as an unplugged power cord or as major as a damaged hard disk drive. The information in this troubleshooting section is designed to help you find and solve minor problems. If you still have a problem after trying all the suggested remedies in this chapter, contact your dealer.

The problems that you might encounter can be divided into two basic categories: hardware and software. Hardware problems can be further divided into being of an electrical or a mechanical nature. You will know you have a hardware problem if, for example, the screen is blank, or your computer cannot recognize the disk drives.

Software problems can occur at several levels. Both your operating system and your software application programs are capable of generating errors and error messages. If you encounter a software error, try to determine if the error message is from your operating system or from an application program, and refer to the appropriate manual for possible remedies.

You can also refer to the Windows manual or Windows help program to solve the problem. To access the help program, click *start –Help and Support*. It also gives you troubleshooting tips and an index.

Successful troubleshooting is the result of careful observation, deductive reasoning, and an organized approach to solving the problem. If you encounter a problem, begin by performing a careful visual inspection. Check the exterior of your computer first. If no lights are lit, check the battery charge or power outlet, the plug and power cord, and any power switches that may affect your computer. If your computer has been connected to any peripheral devices, look for loose or disconnected cables. You may also need to check the fuses and breakers in your electric box. A few common problems and suggested solutions are presented in the examples that follow.

Trouble when Starting

Question: Why doesn't the power indicator or the battery indicator turn on?

- Make sure the AC adapter is correctly connected to the AC adapter jack of your computer.
- Make sure the AC power cable is correctly connected to a live wall outlet. Connect another electric equipment to the wall outlet and check whether it is live or not.
- Make sure the battery pack is correctly installed and charged.
- If the battery pack is discharged, connect the AC adapter.

Question: Why do I get the message “Remove disks or other media. Press any key to restart.”?

- You may have inserted a non-bootable disk in the optional external floppy disk drive unit (either a defective disk or one without an installed operating system). Remove the disk.

Question: Why can't I boot from the floppy disk?

- Make sure that the optional external floppy disk drive unit is correctly connected to your computer.
- Check whether the floppy disk set to the optional external floppy disk drive unit contains a system disk.
- Check whether *Floppy Disk Drive* is set to the top of the list in *Boot Sequence* and *USB FDD* is set to *Enabled* in *Boot* menu of the Setup Utility.

Question: Why do I get the message *Press<F1> to resume, <F2> to setup*?

- The setting of the Setup Utility is deleted. Run the Setup Utility and get default value of the Setup Utility. Be sure to set the date and time correctly.

Question: Why do I get the message *Operating system not found*?

- Run the Setup Utility and get default value of the Setup Utility. Be sure to set the date and time correctly.

Trouble with Display

See the *Adjusting Display* in Chapter 2 or *External Display* in Chapter 5.

Question: Why is the screen blank?

- Press any key to see if any power management feature has turned off the screen to save power.
- See the power indicator to check whether your computer is turned on.
- If you are using a battery pack, make sure it is correctly installed and has a charge remaining.
- Make sure the LCD screen is selected as the display by pressing **Fn+F5** (⏏).
- Check whether the display is on by pressing **Fn+F11** (⏏).
- If you still have the problem after trying the above, follow the steps in *Why doesn't the keyboard or the glide pad function?*

Question: Why does the external monitor display nothing or the image on it distorted?

- Confirm the monitor is turned on.
- Confirm the monitor is connected correctly.
- Make sure an external monitor is selected as the display by pressing **Fn+F5** (⏏).
- If you use **Fn+F5** to change the display, the image may be distorted. Press **Fn+F5** (⏏) again to return the previous display and use *Display Properties* dialog box to change it again. (Refer to Chapter 5.)
- Make sure the value of the *Screen resolution* in the *Settings* tab of the *Display Properties* is same as or lower than the resolution of the external monitor.
- Make sure the external monitor is not near any electric devices having strong magnetic fields such as a TV set or radio.
- Do not share an outlet with a TV set or radio.

Question: Why can't I change the display with **Fn+F5** (⏏) keys?

- When playing the animation or game, **Fn+F5** (⏏) key combination may not work. Close the currently running application.

- Use *Display Properties* dialog box to change it. (Refer to Chapter 5.)
- When you select *Extended Desktop* mode, **Fn+F5** (⏏) key combination does not work.

Trouble with Keyboard/Glide Pad

Question: Why doesn't the keyboard or the glide pad function?

- Try the following in this order:
 1. Press the windows security button (⏏) or **Ctrl+Alt+Delete** key combination and select *Users* tab of *Windows Task Manager* dialog box. Click *Disconnect* or *Logoff*; then, *Yes*.
 2. If the step 1 fails to work, slide and hold the power switch for more than four seconds to turn off the system. Ten seconds later, turn your computer on.
 3. If you still cannot turn off the system with the power switch, confirm the hard disk indicator is not lit and press the reset switch on the bottom of your computer to turn off the system (refer to *Resetting System* section of Chapter 2). Ten seconds later, turn on your computer by sliding the power switch.

Question: Why does the glide pad malfunction?

- The surface of the glide pad or your palm may be moist or dirty and grease. Wipe the glide pad with a soft, dry cloth.

Trouble with Tablet Pen

Question: Why doesn't the tablet pen work properly?

- Follow the instructions below:
 1. Open *Tablet and Pen Settings* dialog box.
 2. In *Pen Options* tab, select an item in *Pen Action* list and click *Settings...* button.
 3. Adjust the settings and Click *OK*.
 4. Close the dialog box.

Question: Why can't you align the pointer on the screen with the pen tip?

- Calibrate the tablet pen. Refer to *Calibrating Tablet Pen* section in Chapter 3.

Trouble with Programmable Button

Question: Why don't the actions of the programmable buttons switch automatically?

- Confirm *Auto change* in *Programmable Buttons Enhanced Utility* menu is checked.
- Confirm the box of the application in *Auto Change* column is checked in *Settings of Programmable Buttons Enhanced Utility* dialog box.

Trouble with Floppy Disk

Question: Why can't I use a floppy disk?

- Confirm the optional external floppy disk drive unit is correctly connected.
- Confirm the floppy disk is inserted correctly.
- Confirm the drive or file name is correct.
- The floppy disk may not be formatted or could be corrupted. Format the disk or use another disk.
- If you cannot write to a floppy disk, the disk may be write-protected. Eject the disk and ensure that the write-protect tab covers the detection hole.
- If you cannot write to a floppy disk, the disk may be full. Use another disk.

Trouble with Hard Disk

Question: Why can't I read or write data to/from the hard disk?

- Confirm the drive and file names are correct.
- Confirm the hard disk has sufficient free space.

Trouble with CD

Question: Why can't I read data from a compact disc or play files?

- Confirm the external optical drive unit is correctly connected to your computer.
- Confirm the CD is inserted correctly.
- Confirm the drive and file names are correct.
- Confirm the CD is not stained or scratched.

- Confirm the CD or files are supported.

Trouble with Communication

Question: Why can't I communicate through the built-in modem?

- Confirm the telephone line is properly connected to the modem jack.
- Confirm the dial setting (pulse or tone) of Windows or communication software is matched with the telephone line.
- Confirm the country/region setting is appropriate.
- Confirm the network configuration is appropriate.
- Confirm the user name or password is correct.
- Confirm the COM port in the communication software is set appropriately.
- Turn off the power management in the Windows.
- If an unusual device is attached to the line you are connecting to, the modem may not function properly. Remove the device or contact the dealer of the device.
- If connected to a PBX, consult the PBX maintenance staff or its service company. If the electric characteristics of your PBX are different from those of a regular analog line, the modem will not function properly. If you connect the modem to a digital PBX, both the modem and the PBX may be damaged.

Question: Why is the communication speed so slow?

- Close the applications currently opened.
- Try to connect another ISP (Internet Service Provider), or try to connect in some other time.

Question: Why can't I access the LAN?

- Confirm the cable is properly connected to the LAN jack and the network hub.
- Confirm the network configuration is appropriate.
- Confirm the user name or password is correct.

Question: How can I detect the MAC address?

- Follow the instructions below:
 1. Click *start – All Programs – Accessories – Command Prompt*.

2. Type `ipconfig/all`; then, press **Enter**. The IP information appears.
3. For the LAN, see the numbers of *Physical Address* in *Ethernet adapter Local Area Connection* section. For the Wireless LAN, see the numbers of *Physical Address* in *Ethernet adapter Wireless Network Connection* section.
4. Type `exit`; then, press **Enter**.

Question: Why can't I detect the access point on my computer? (for wireless LAN communication)

- Confirm the access point is powered on.
- Confirm the antenna indicator is lit.
- Restart your computer.
- Confirm your computer is enabled for the wireless LAN.
- Detect the access point by following the steps below.
 1. Click *start – Control Panel*.
 2. Click *Network and Internet Connections – Network Connections* in Category view. In Classic view, double-click *Network Connections* icon. *Network Connections* dialog box appears.
 3. Right-click *Wireless Network Connection*; then, click *Disable*.
 4. Right-click *Wireless Network Connection*; then, click *Enable*.
- When you have more than one available access points, your computer may be connected to the access point other than the one you want to access:
 1. Right-click *Wireless Network Connection* icon () on the taskbar; then, click *View Available Wireless Networks*.
 2. Select the desired network in the *Available wireless networks* list; then, connect to the network. (Refer to *Confirming Status of Wireless Connection* section in Chapter 6.)

Question: Why can't I connect to the network via an access point? (for wireless LAN communication)

- Confirm the wireless LAN antennas are enabled. When the antenna indicator lights green, the antennas are enabled. If not, press **Fn+F1** () keys.
- Confirm *Any available network (access point preferred)* is selected in *Networks to access* of *Advanced* dialog box. (To open *Advanced* dialog box, refer to *Communicating with Other Computers* section of *Wireless LAN* in Chapter 6.)

- Confirm the ESSID of your computer matches the ESSID of the access point you want communicate with.
- Confirm the *Network key* is correctly entered if the WEP security of the access point is enabled.
- You may accidentally enable IEEE802.1x authentication. Disable it with the following steps.
 1. Click *start – Control Panel*.
 2. Click *Network and Internet Connections – Network Connections*. If Classic view is selected, double-click *Network Connections*.
 3. Right-click *Wireless Network Connection* and click *Properties*.
 4. Click *Wireless Networks* tab, select the network in *Preferred networks* field and click *Properties* button.
 5. Select *Authentication* tab, then, uncheck the box of *Enable IEEE802.1x authentication for this network*.
 6. Click *OK* twice and close the window.

Question: Why can't I communicate with other computers through a wireless LAN?

- Confirm the wireless LAN antennas are enabled. When the antenna indicator lights green, the antennas are enabled. If not, press **Fn+F1** () keys.
- Confirm each computer is enabled for wireless LAN.
- Confirm *Computer-to-computer (ad hoc) networks only* is selected in *Networks to Access of Advanced* dialog box of each computer. (To open *Advanced* dialog box, refer to *Communicating with Other Computers* section of *Wireless LAN* in Chapter 6.)
- Adjust the distance between the computers by bringing your computer closer to others and remove any obstructions that may impede the communication; then, try to connect again. (The distance between computers or access points should be less than approximately 190 ft. (60 m) in the direct line-of-sight.)
- Confirm the IP address and the subnet mask of each computer are set correctly.
- Confirm the WEP key is correctly entered if the WEP security of other devices, which you want to communicate with, is enabled.

Trouble with Peripherals

Question: Why don't peripheral devices function correctly?

- Confirm they are correctly connected to your computer.
- Confirm they are Windows XP compliant.
- Confirm drivers necessary for the devices are installed.
- Set *System standby* and *System hibernates* to *Never* in *Power Options Properties* dialog box. If this does not work, set *Turn off hard disks* to *Never*.

Question: Why can't I print?

- Make sure the printer is turned on.
- Check whether your computer and the printer are connected correctly.
- Check whether the printer is ready to print.
- Check whether the printer has enough paper.
- Check whether the printer driver is installed.
- From the *start* menu, select *Control Panel – Printers and Other Hardware -Printers and Faxes*. If Classic view is selected, double-click *Printers and Faxes* icon. Confirm your printer is installed there. If not, click *Add a printer* or *Printer Tasks* to install your printer.
- See also the Windows help program by clicking *start – Help and Support*.

Other Troubles

Question: Why is the battery pack discharged so quickly?

- Initialize the battery pack.

Question: Why is the date and/or time incorrect?

- Correct the date and time in Windows. Double-click the time appearing on the taskbar and set them in *Date and Time Properties* dialog box.

Question: Why can't I use a hardware device?

- Make sure the hardware device is not crossed out with an X mark using the following procedure.

1. Click *start– Control Panel*.

2. Click *Performance and Maintenance*; then, *System*. If Classic view is selected, double-click *System* icon.
3. Click *Hardware* tab; then, *Device Manager*.
4. Double-click the device you cannot use.
5. Confirm *Use this device (enable)* appears in *Device usage*.

Question: Why can't I produce sound?

- Click or double-click the speaker symbol on the taskbar and check the Windows volume.

Question: Why can't I turn off my computer?

- Follow the instructions on *Why doesn't the keyboard or the glide pad function?* section.

Question: Why my computer is so hot?

- When charging the battery pack, its surrounding area or the front of the keyboard may become hot, but this is not a problem.

Question: Why can't I record the sound from the microphone?

- Follow the instructions below:
 1. Double-click the speaker symbol on the taskbar.
 2. Click *Options* and select *Properties*.
 3. Select *Recording* in *Adjust volume for* and confirm *Microphone* is checked in *Show the following volume controls*; then click *OK*.
 4. Confirm the box of *Select* is checked in *Microphone of Recording Control* dialog box.
 5. Close the *Recording Control* dialog box.

Question: Why can't find the drivers and applications?

- You may accidentally remove them. They are stored on the last recovery disk if you have created recovery CDs. (i.e. when three recovery CDs are created, they are stored on the "Disk 3".) When you are not sure how to install them or the CD does not have the drivers or applications, consult local service staff.

Index

A

- AC adapter
 - connecting, 1-3
 - using, 2-2
- Account
 - creating, 2-10
 - switching, 2-10
- Antenna indicator, 6-9
- Audio
 - connecting audio equipment, 5-8
 - connecting headphone, 5-9
 - connecting microphone, 5-9
 - connecting speakers, 5-8
 - controlling output volume, 2-7

B

- Battery pack
 - changing, 4-4
 - charging, 4-2
 - checking level, 4-2
 - conditioning, 4-4
 - indicator, 2-1, 4-3
 - installing, 1-1
 - low battery indication, 4-3

C

- Cleaning
 - computer, A-5
 - tablet pen, A-5
- CD
 - troubleshooting, T-5
- Compact flash card,
 - ejecting, 5-17
 - inserting, 5-15

D

- Display
 - adjusting orientation, 3-10
 - changing brightness, 2-8
 - changing number of colors, 2-8
 - changing resolution, 2-8
 - closing, 1-8
 - opening, 1-4
 - rotating, 2-9, 3-1
 - switching, 2-6, 5-7
 - troubleshooting, T-3
 - turning off, 2-6

E

- Encryption key, 6-12
- External monitor
 - connecting, 5-6
 - disconnecting, 5-7
 - displaying, 5-7
 - switching, 2-6, 5-7

F

- File sharing
 - sharing, 6-7
 - copying, 6-8
- Floppy disk
 - ejecting, 5-4
 - formatting, 5-5
 - handling, 5-3
 - inserting, 5-4
 - troubleshooting, T-5
- Floppy disk drive unit (external)
 - connecting, 5-3
 - removing, 5-5

G

Glide pad

- changing configuration, 2-5
- clicking and double-clicking, 2-5
- drag and drop, 2-5
- scroll, 2-5
- troubleshooting, T-4
- using, 2-4

H

Hard disk drive

- troubleshooting, T-5

I

IEEE1394 device

- connecting, 5-21
- disconnecting, 5-21

Indicators

- antenna, 6-9
- battery, 2-1, 4-3
- power, 1-4, 2-1
- status, xiv

K

Keyboard

- function keys, 2-6
- special keys, 2-6
- troubleshooting, T-4
- windows key, 2-6

L

LAN

- configuring, 6-5
- configuring network setting, 6-6
- connecting to network, 6-4
- troubleshooting, T-6

M

Memory module

- installing, A-1
- uninstalling, A-4

Modem

- configuring, 6-3

- connecting to telephone line, 6-2
- troubleshooting, T-6

N

Network setup utility

- changing, 6-14
- deleting, 6-14
- loading, 6-13
- switching, 6-13

P

Passwords

- changing, 2-12, 7-5
- deleting, 2-12, 7-6
- setting, 2-11, 7-5
- supervisor, 7-5
- user, 7-5

PC cards

- ejecting, 5-13
- inserting, 5-11

Peripherals

- audio equipment, 5-8
- compact flash card, 5-15
- connecting guidelines, 5-1
- external floppy disk drive, 5-3
- external monitor, 5-6
- headphones, 5-9
- IEEE1394 device, 5-20
- microphone, 5-9
- PC card, 5-11
- printer, 5-19
- speakers, 5-8
- troubleshooting, T-9
- USB device, 5-10

Power

- choosing AC or battery, 2-1
- indicator, 1-4, 2-1

Power management

- controlling CPU speed, 4-7
- disabling, 4-10
- stopping power supply to display, 4-6
- stopping power supply to hard disk, 4-6
- system hibernate, 4-8
- system standby, 4-8

Printer, 5-19

- Programmable button
configuring, 3-13

- copying setting, 3-15
- creating setting, 3-14
- deleting setting, 3-16
- loading, 3-17
- disabling auto switch, 3-16
- modifying setting, 3-15
- settings box, 3-17
- programmable button menu, 3-14
- using, 3-12

R

- Re-install the system
 - CD recovery, A-15
 - creating recovery CD, A-12
 - hard disk recovery, A-10
 - preparation, A-9
- Resetting
 - power switch, 2-3
 - reset switch, 2-3

S

- Screen Saver, 2-9
- Security cable, A-4
- Setup utility
 - advanced menu, 7-4
 - boot menu, 7-6
 - changing, 7-2
 - entering and exiting, 7-2
 - exit menu, 7-7
 - main menu, 7-3
 - running, 7-1
 - security menu, 7-4
- Status indicators, xiv
- System hibernate
 - about, 4-8
 - generating conditions, 4-9
 - resuming from, 4-8
 - supporting, 4-9
- System standby
 - about, 4-8
 - generating conditions, 4-9
 - resuming from, 4-8

T

- Tablet mode
 - handling, 3-3
 - switching, 3-2
- Tablet pen
 - calibrating, 3-10
 - cleaning, A-5
 - ejecting, 3-8
 - handling, 3-5
 - inserting, 3-7
 - pen eject switch, 3-8
 - replacing tip, 3-6
 - using, 3-8, 3-9
- Troubleshooting
 - common problems, T-1
 - communications, T-6
 - display, T-3
 - external floppy disk drive, T-5
 - hard disk drive, T-5
 - keyboard or glide pad, T-4
 - LAN, T-6
 - peripherals, T-9
 - programmable button, T-5
 - tablet pen, T-4
 - wireless LAN, T-7

U

- USB device, 5-10

W

- Wallpaper, 2-9
- Windows security button, 3-12
- Windows XP
 - first-time setup, 1-5
 - properties dialog boxes, 1-6
- Wireless LAN
 - activating, 6-9
 - communicating, 6-10
 - confirming status, 6-11
 - connecting to access point, 6-10

