

TOSHIBA

OWNER'S MANUAL

3LCD DATA PROJECTOR

TLP780U

TLP781U *(WITH DOCUMENT IMAGING CAMERA)*

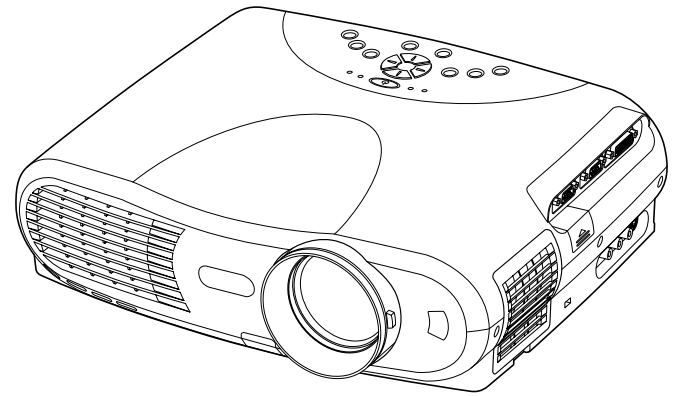

TLP780U

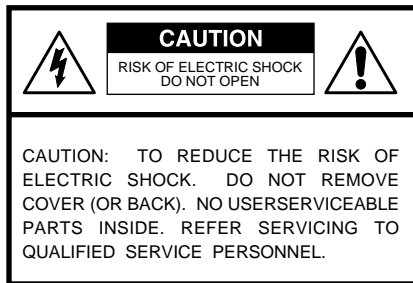

 The lightning flash with arrowhead symbol, within an equilateral triangle, is intended to alert the user to the presence of uninsulated "dangerous voltage" within the product's enclosure that may be of sufficient magnitude to constitute a risk of electric shock to persons.

 The exclamation point within an equilateral triangle is intended to alert the user to the presence of important operating and maintenance (servicing) instructions in the literature accompanying the appliance.

WARNING: TO REDUCE THE RISK OF FIRE OR ELECTRIC SHOCK, DO NOT EXPOSE THIS APPLIANCE TO RAIN OR MOISTURE. DANGEROUS HIGH VOLTAGES ARE PRESENT INSIDE THE ENCLOSURE. DO NOT OPEN THE CABINET. REFER SERVICING TO QUALIFIED PERSONNEL ONLY.

FCC Radio Frequency Interference Statement

Note: This equipment has been tested and found to comply with the limits for a Class A digital device, pursuant to part 15 of the FCC Rules. These limits are designed to provide reasonable protection against harmful interference when the equipment is operated in a commercial environment. This equipment generates, uses, and can radiates radio frequency energy and, if not installed and used in accordance with the instruction manual, may cause harmful interference to radio communications. Operation of this equipment in a residential area is likely to cause harmful interference in which case the user will be required to correct the interference at his own expense.

WARNING: Changes or modifications made to this equipment, not expressly approved by Toshiba, or parties authorized by Toshiba, could void the user's authority to operate the equipment.

Notice: This Class A digital apparatus complies with Canadian ICES-003. Cet appareil numérique de la classe A est conforme à la norme NMB-003 du Canada.

CAUTION: Laser beam is emitted when the laser button of the remote control is pressed. Do not look from the front of the remote control. Do not face toward a person or to a mirror.

IMPORTANT PRECAUTIONS

Save Original Packing Materials

The original shipping carton and packing materials will come in handy if you ever have to ship your LCD projector. For maximum protection, repack the set as it was originally packed at the factory.

Avoid Volatile Liquid

Do not use volatile liquids, such as an insect spray, near the unit. Do not leave rubber or plastic products touching the unit for a long time. They will mar the finish.

Moisture Condensation

Never operate this unit immediately after moving it from a cold location to a warm location. When the unit is exposed to such a change in temperature, moisture may condense on the crucial internal parts. To prevent the unit from possible damage, do not use the unit for at least 2 hours when there is an extreme or sudden change in temperature.

In the spaces provided below, record the Model and Serial No. located at the bottom of your LCD projector.

Model No. _____ Serial No. _____

Retain this information for future reference.

CAUTION: PLEASE READ AND OBSERVE ALL WARNINGS AND INSTRUCTIONS GIVEN IN THIS OWNER'S MANUAL AND THOSE MARKED ON THE UNIT. RETAIN THIS BOOKLET FOR FUTURE REFERENCE.

This set has been designed and manufactured to assure personal safety. Improper use can result in electric shock or fire hazard. The safeguards incorporated in this unit will protect you if you observe the following procedures for installation, use and servicing. This unit is fully transistorized and does not contain any parts that can be repaired by the user.

DO NOT REMOVE THE CABINET COVER, OR YOU MAY BE EXPOSED TO DANGEROUS VOLTAGE. REFER SERVICING TO QUALIFIED SERVICE PERSONNEL ONLY.

1. Read Owner's Manual

After unpacking this product, read the owner's manual carefully, and follow all the operating and other instructions.

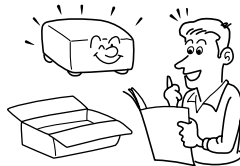

2. Power Sources

This product should be operated only from the type of power source indicated on the marking label. If you are not sure of the type of power supply to your home, consult your product dealer or local power company.

For products intended to operate from battery power, or other sources, refer to the operating instructions.



3. Source of Light

Do not look into the lens while the lamp is on. The strong light from the lamp may cause damage to your eyes or sight.



4. Ventilation

Openings in the cabinet are provided for ventilation and to ensure reliable operation of the product and to protect it from overheating, and these openings must not be blocked or covered. The openings should never be blocked by placing the product on a bed, sofa, rug or other similar surface. This product should not be placed in a built-in installation such as a bookcase or rack unless proper ventilation is provided or the manufacturer's instructions have been adhered to.

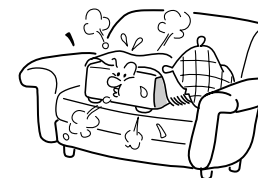

5. Heat

The product should be situated away from heat sources such as radiators, heat registers, stoves, or other products (including amplifiers) that produce heat.

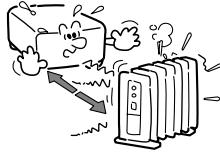

7. Cleaning

Unplug this product from the wall outlet before cleaning. Do not use liquid cleaners or aerosol cleaners. Use a damp cloth for cleaning.

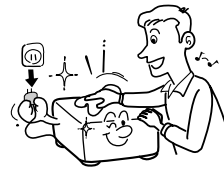

9. Overloading

Do not overload wall outlets; extension cords, or integral convenience receptacles as this can result in a risk of fire or electric shock.

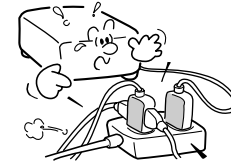

6. Water and Moisture

Do not use this product near water - for example, near a bath tub, wash bowl, kitchen sink, or laundry tub; in a wet basement; or near a swimming pool and the like.

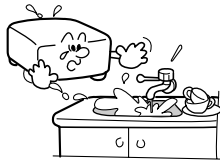

8. Power-Cord Protection

Power-supply cords should be routed so that they are not likely to be walked on or pinched by items placed upon or against them, paying particular attention to cords at plugs, convenience receptacles, and the point where they exit from the product.



10. Lightning

For added protection for this product during storm, or when it is left unattended and unused for long periods of time, unplug it from the wall outlet. This will prevent damage to the product due to lightning and power-line surges.

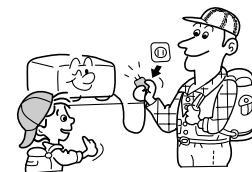

11. Object and Liquid Entry

Never push objects of any kind into this product through openings as they may touch dangerous voltage points or short-out parts that could result in a fire or electric shock. Never spill liquid of any kind on the product.



13. Stack Inhibited

Do not stack other equipment on this product or do not place this product on the other equipment. Top and bottom plates of this product develops heat and may give some undesirable damage to other unit.



12. Do not place the product vertically

Do not use the product in the upright position to project the pictures at the ceiling, or any other vertical positions. It may fall down and dangerous.

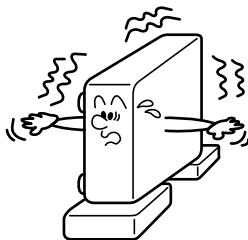

15. Accessories

Do not place this product on an unstable cart, stand, tripod, bracket, or table. The product may fall, causing serious injury to a child or adult, and serious damage to the product. Use only with a cart, stand, tripod, bracket, or table recommended by the manufacturer, or sold with the product. Any mounting of the product should follow the manufacturer's instructions, and should use a mounting accessory recommended by the manufacturer. A product and cart combination should be moved with care. Quick stops, excessive force, and uneven surfaces may cause the product and cart combination to overturn.

14. Attachments

Do not use attachments not recommended by the product manufacturer as they may cause hazards.



16. Damage Requiring Service

Unplug this product from the wall outlet and refer servicing to qualified service personnel under the following conditions:

- a) When the power-supply cord or plug is damaged.
- b) If liquid has been spilled, or objects have fallen into the product.
- c) If the product has been exposed to rain or water.
- d) If the product does not operate normally by following the operating instructions. Adjust only those controls that are covered by the operating instructions as an improper adjustment of other controls may result in damage and will often require extensive work by a qualified technician to restore the product to its normal operation.
- e) If the product has been dropped or damaged in any way.
- f) When the product exhibits a distinct change in performance - this indicates a need for service.

17. If glass components, including lens and lamp, should break, contact your dealer for repair service.

This product incorporates glass components, including a lens and a lamp. If such parts should break, please handle with care to avoid injury and contact your dealer for repair service. The broken pieces of glass may cause to injury.

In the unlikely event of the lamp rupturing, thoroughly clean the area around the projector and discard any edible items placed in that area.

18. Servicing

Do not attempt to service this product yourself as opening or removing covers may expose you to dangerous voltage or other hazards. Refer all servicing to qualified service personnel.



19. Replacement Parts

When replacement parts are required, be sure the service technician has used replacement parts specified by the manufacturer or have the same characteristics as the original part. Unauthorized substitutions may result in fire, electric shock, or other hazards. (Replacement of the lamp only should be made by users.)

20. Safety Check

Upon completion of any service or repairs to this product, ask the service technician to perform safety checks to determine that the product is in proper operating condition.

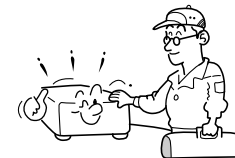

- 21. Do not get your hands between the camera arm and the main unit when setting the camera arm back in its original position.**

To avoid injury, be careful not to get your hands caught when setting the camera arm back in its original position. Families with children should be particularly careful.

- 23. Do not leave documents on the unit for long periods of time while using the document imaging function.**

Do not leave texts, papers or other documents for projection on the unit for long periods of time. The heat could erase the letters on a thermal paper.

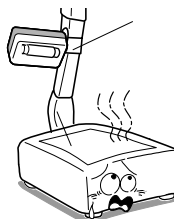

- 25. Do not look into the arm light while it is lit.**

The strong light may cause damage to your eyes or sight.

- 22. Do not carry by the camera arm.**

Do not carry the projector by the camera arm.

Doing so can result in damage or injury.





- 24. Do not move the projector while the arm is still erect.**

Always store the arm back in position when moving the projector. Otherwise injury or damage may result.



Power supply cord selection

If your line voltage is 220 to 240V, use one of the following types of cable.

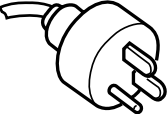
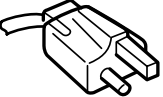
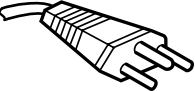
Plug configuration	Plug type	Line voltage
	EURO 240V 10 - 15A	220 – 240V
	UK 240V 6A	200 – 240V
	Australian 240V 10A	200 – 240V
	North American 240V 15A	200 – 240V
	Switzerland 240V 6A	200 – 240V

Before use

SAFETY PRECAUTIONS	2
IMPORTANT PRECAUTIONS	3
IMPORTANT SAFETY INSTRUCTIONS	4
Power supply cord selection	9
Contents	10
Names of each part on the main unit	11
Names of each part on the remote control	13
Loading batteries	15
Remote control operation	16

Installation and connections

Floor-mounted projector placement	17
Projector placement angle adjustment	20
Ceiling-mounted projector placement	21
Connecting a computer (COMPUTER IN 1 connector)	22
Connecting a computer (COMPUTER IN 2 connector)	23
Connecting video equipment	24
Projector operation control by a computer	26
How to use the output connector	27

Operations

Projection on the screen	28
Turning the power off	33
Adjusting the picture automatically	34
Correcting the keystone distortion	35
Cutting off the picture and sound temporarily	37
Freezing the picture	38
Enlarging the picture size	39
Displaying PIP Sub-pictures	40
Displaying Information	41
Operating a computer by the remote control	42

Adjustments & Settings

Operating the menu screen	43
GUIDE MENU adjustments and settings	45
FULL MENU adjustments and settings - Picture	46
FULL MENU adjustments - Position	47
FULL MENU adjustments - Color	48
FULL MENU adjustments and settings - Audio	49
FULL MENU adjustments and settings - Display	50
FULL MENU settings - Default setting	51
FULL MENU settings - Reset	52
PIP menu setting	53

Document imaging camera

Part names (of the document imaging camera model)	54
Preparation of the document imaging camera	55
Picture projection with the document imaging camera	56
Overlaying projection	59
Lock the white balance	60
Correcting illuminated defects	61

Maintenance

Trouble indications	62
Air filter cleaning	63
Lens and main unit cleaning	65
Lamp replacement	66

Others

Before calling service personal	68
Pin assignment of COMPUTER IN, MONITOR OUT connector	70
Applicable signal	71
Controlling the projector by using RS-232C	73
Specifications	79

Names of each part on the main unit

CAUTION

Openings in the cabinet are provided for ventilation and to ensure reliable operation of the product and to protect it from overheating, and these openings must not be blocked or covered.

The explanation here is only for the model not with the document imaging camera. For the model with the document imaging camera, refer to [54](#).

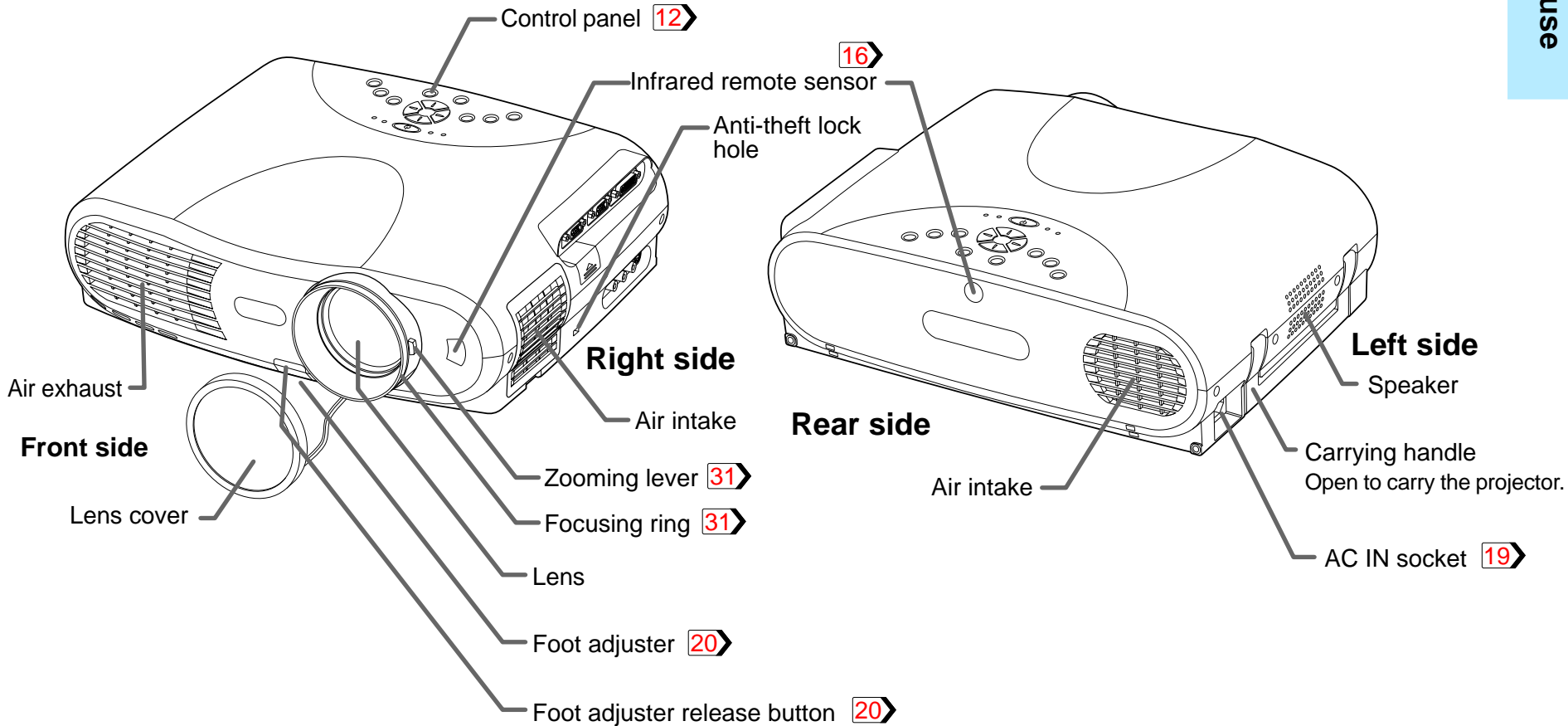

• The air exhaust discharges high temperature air. Do not put something around the air exhaust, otherwise it may be deformed by the high temperature air.

Names of each part on the main unit (continued)

To display the menu screen and/or select the operation on the menu screen. **43** **44**

Use the selection button and **EXIT** button to enlarge the image. **39**

ON/STANDBY button **28** **33**

To turn the projector on or off (standby).

ON indicator **28** **33** **62**

LAMP indicator **28** **33** **62**

TEMP indicator **62**

FAN indicator **28** **33** **62**

To indicate the status of the projector.

VOL/ADJ button **44**

To set and/or adjust values on the menu.

To adjust volume when the menu is not displayed. **32**

AUTO SET button **34**

To adjust the image of the Computer input automatically.

KEYSTONE button **35**

To correct the keystone distortion of the picture.

INPUT button **30**

To select the input source.

EXIT button

Selection button

ENTER button

MENU button

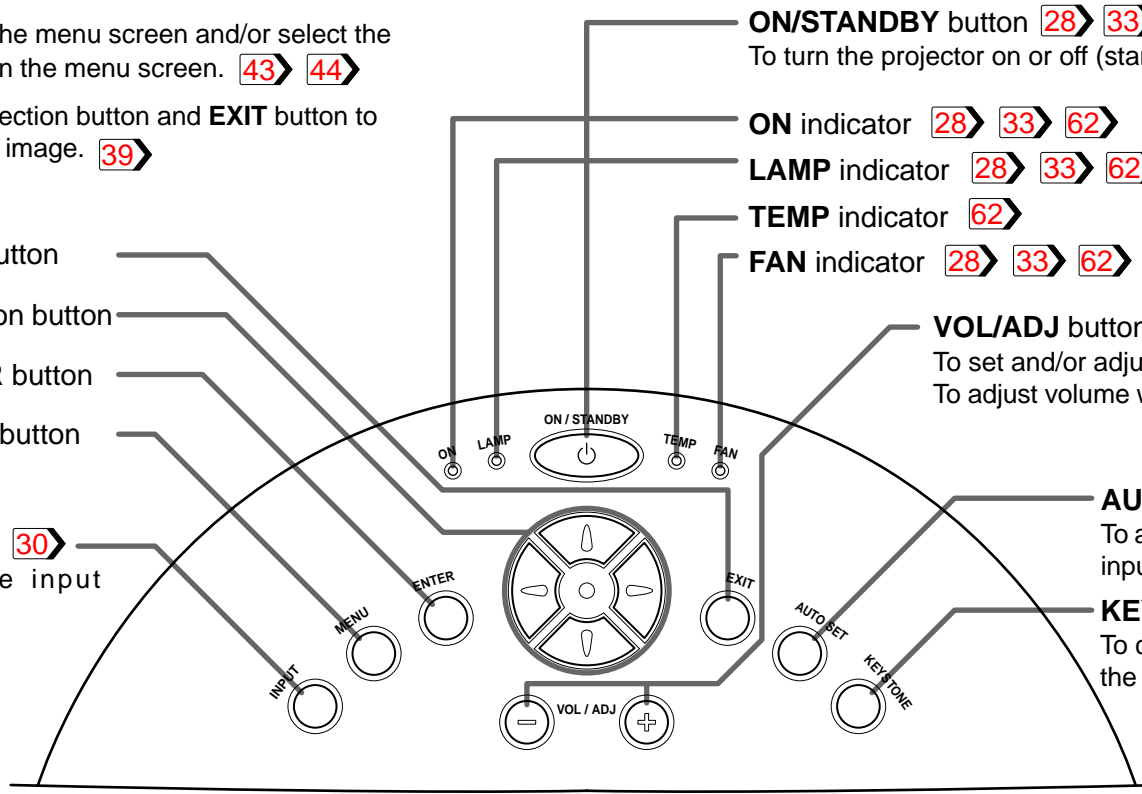

Top side
Control panel

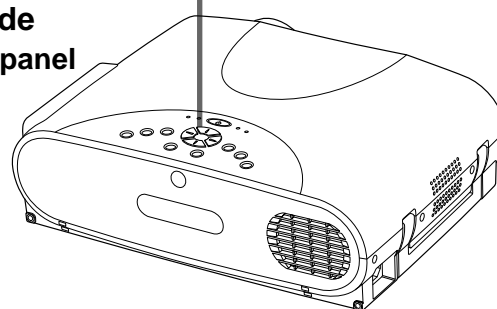

Names of each part on the main unit (continued)

CONTROL connector [26](#) [73](#)
(RS-232C connector)
To connect a computer to control the projector. (Remove the cover when using the connector.)

USB connector [42](#)
To connect to a USB connector of a computer when using the remote control mouse.

MONITOR OUT connector [27](#)
To connect a monitor, etc.

COMPUTER IN 1 connector [22](#) [25](#)
To enter RGB signal from a computer, etc or component video signal (Y/P_B/P_R Signal) from a video equipment.

COMPUTER IN 2 connector [23](#)
To enter RGB signal from a computer, etc.

S-VIDEO connector [24](#)
To enter S-Video signal from a video equipment, etc.

VIDEO jack [24](#)
To enter video signal from a video equipment, etc.

AUDIO(L/R) jacks [24](#)
To enter audio signal from a video equipment, etc.

AUDIO IN jack (Audio input) [22](#) [25](#)
(ϕ 3.5mm stereo mini-jack)
To enter audio signal from a computer or a video equipment with component video output (Y/P_B/P_R signal output) supported.

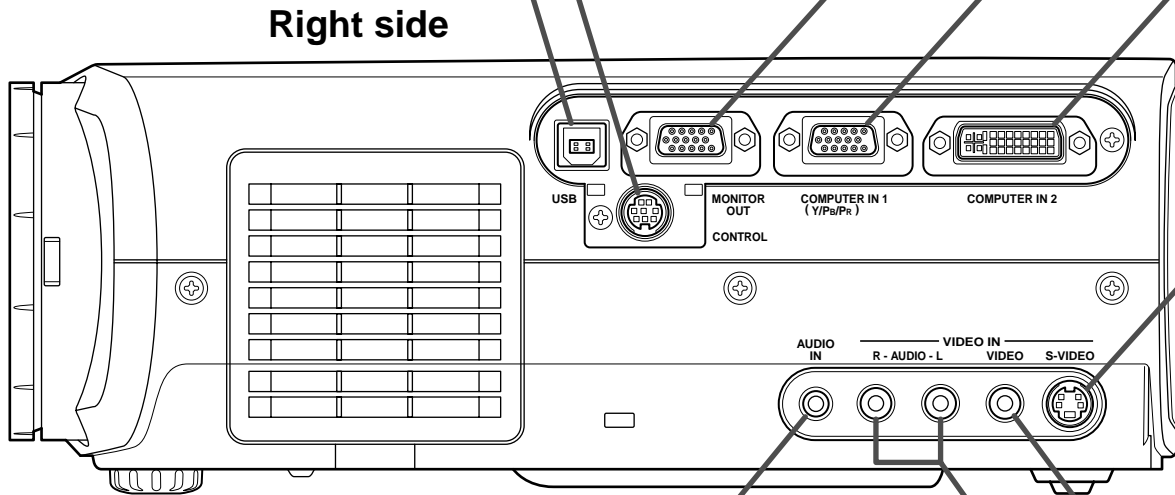

Names of each part on the remote control

Caution - use of controls or adjustments or performance of procedures other than those specified herein may result in hazardous radiation exposure.

Location of the labels

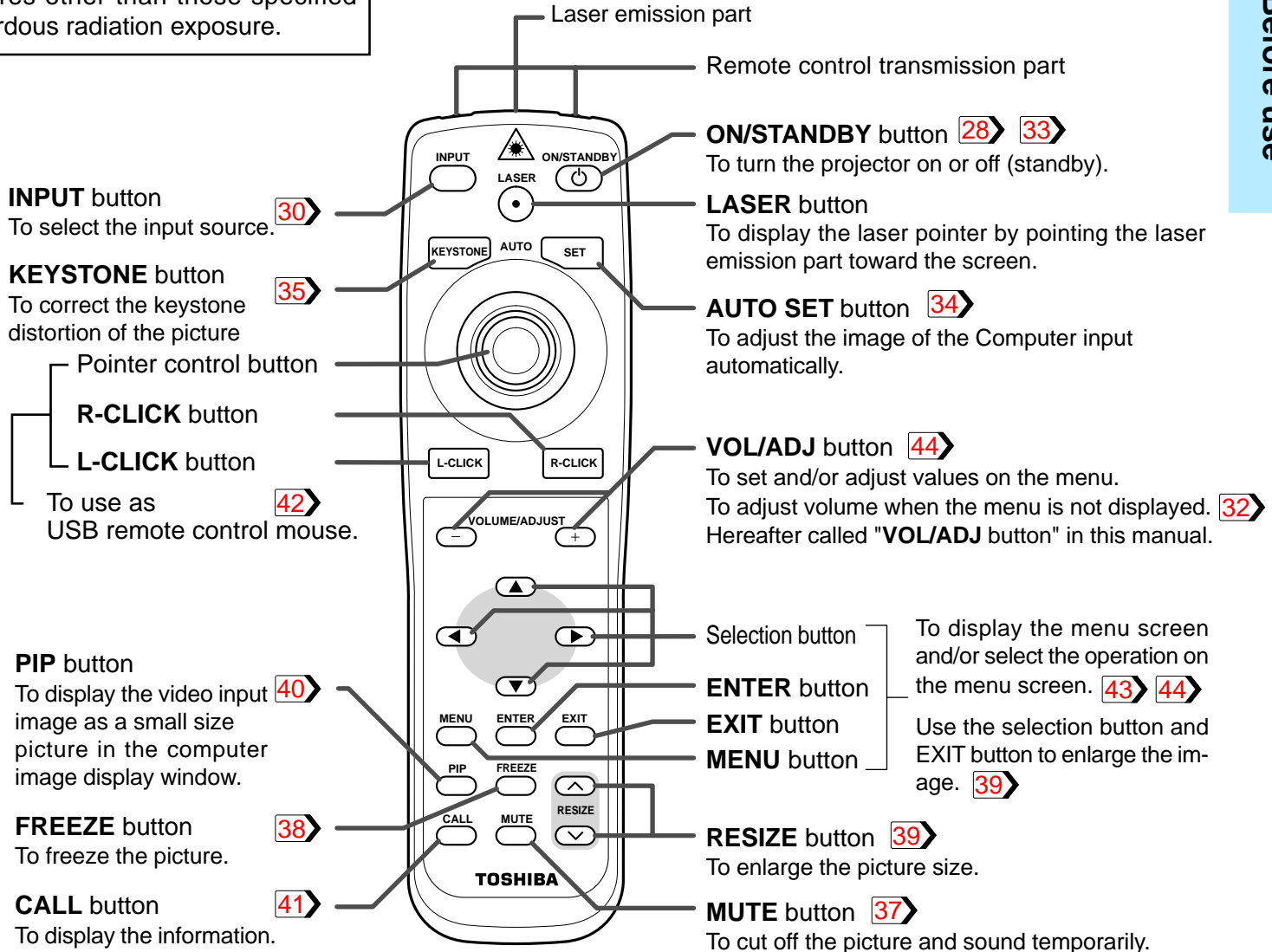
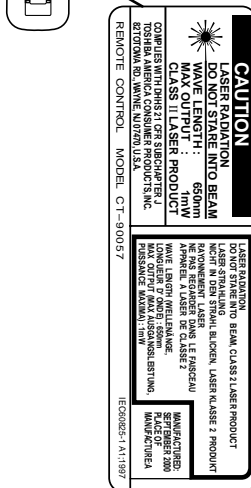
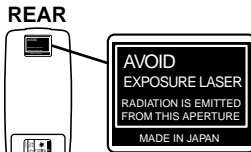

Notes

Using batteries incorrectly can cause them to leak or burst. Strictly observe the following.

- Install the batteries with their + and - ends facing correctly.
- Do not charge, heat, disassemble, or short the batteries or throw them into a fire.
- Do not leave exhausted batteries in the remote control.
- Do not mix different types of batteries or new and old batteries.
- When you will not be using the remote control for a prolonged period, take the batteries out of the remote control.
- When the remote control stops working or only works from very close distance, replace all the batteries with new ones.
- When replacing the batteries, use a more longer life alkaline batteries.
- If a battery leaks, carefully wipe off any residue inside the battery case before loading new batteries.

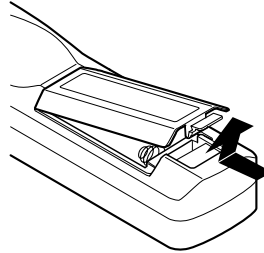
1**(Bottom Side)****Open the cover****2****Install the batteries**

Make sure that the +/- polarities match the illustration in the compartment.

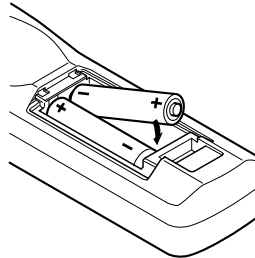
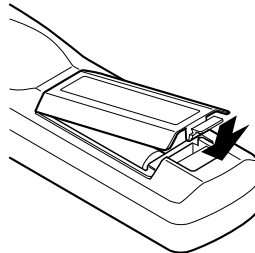
**3****Attach the cover**

Remote control operation

Point the remote control at the infrared remote sensor and press a button.

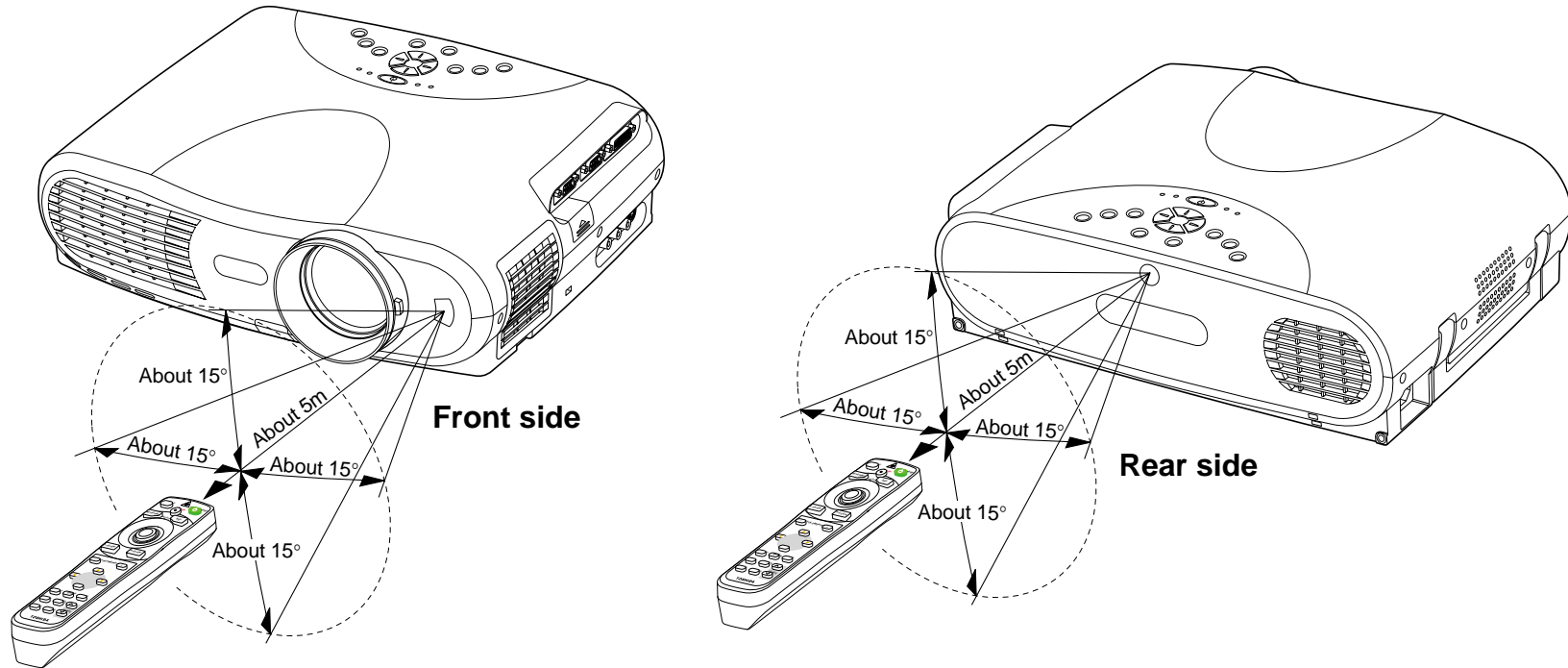

Notes

- The remote control may not operate when there is sunlight or other strong light such as a fluorescent lamp shining on the remote sensor.
- Operate the remote control from a position where the remote sensor is visible.
- Do not drop the remote control or otherwise jolt it.
- Keep the remote control out of locations with excessively high temperature or humidity.
- Do not get water on the remote control or place wet objects on it.
- Do not disassemble the remote control.
- Under unusual circumstances the remote control may not operate well due to the location being used or the surroundings. At such times, change the direction of the remote control to the projector and retry the operation.

Floor-mounted projector placement

There are two ways to place the floor-mounted projector. Perform the "Projection mode" setting on the menu screen for the projection method. [51](#)

For the ceiling-mounted projector placement, refer to the page [21](#).

Floor-mounted front projection

Viewing a picture projected on the front of the screen from a floor installation.

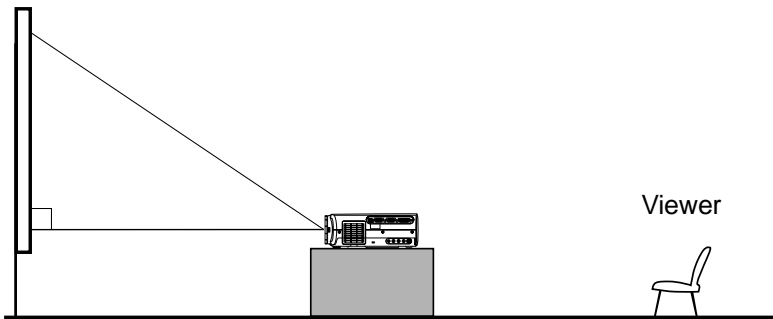

Floor-mounted rear projection

Viewing a picture projected through the back of the screen from a floor installation.

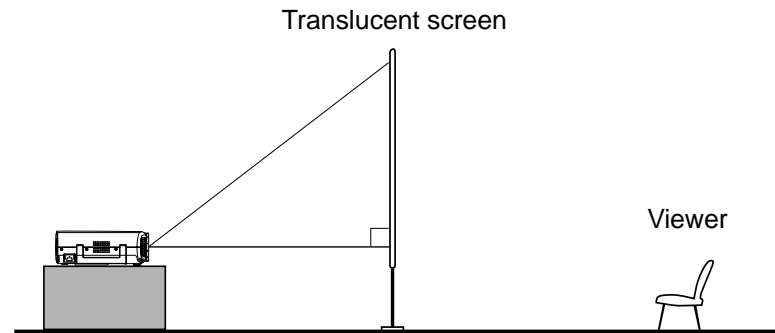

1 Place the projector on a steady, level surface such as a table.

To obtain proper screen projected, place the projector so that the projecting light hits the screen squarely.

Top view

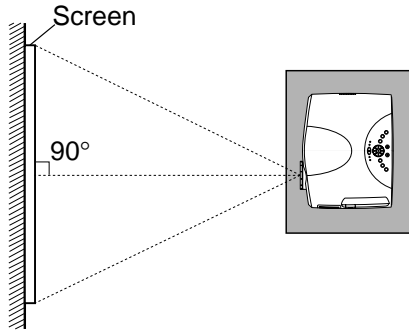

Point the lens straight at the center of the screen as above.

Side view

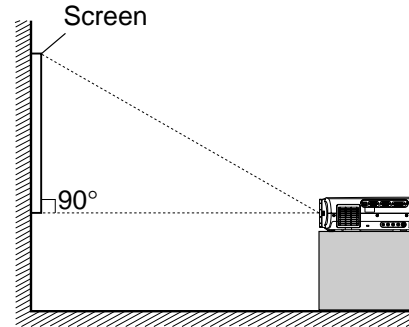

Place the projector horizontally so that the projecting light hits the screen squarely.

2 Determine the screen size projected on the screen.

The projection size depends on the distance between the lens and the screen. Adjust the projection size by changing the distances as shown below.

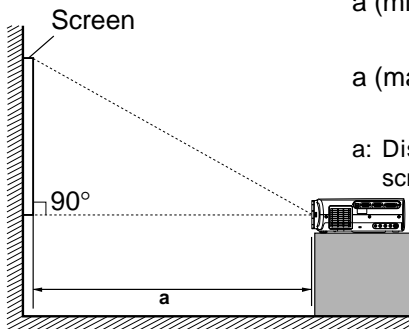

$$a \text{ (min.)} = \frac{\text{Projection size} - 1.6017}{27.041}$$

$$a \text{ (max.)} = \frac{\text{Projection size} - 1.2699}{21.463}$$

a: Distance between the lens and the screen (m)

The values are approximations.

Projection size (inches)	a(m)	
	Minimum (At maximum zoom)	Maximum (At minimum zoom)
32	-	1.42
40	1.42	1.80
60	2.16	2.74
80	2.90	3.67
100	3.63	4.60
150	5.48	6.93
200	7.33	9.26
300	11.02	-

3 Connect the power cord.

- Insert one end in the AC IN socket on the projector.
- Insert the other end in a wall outlet.

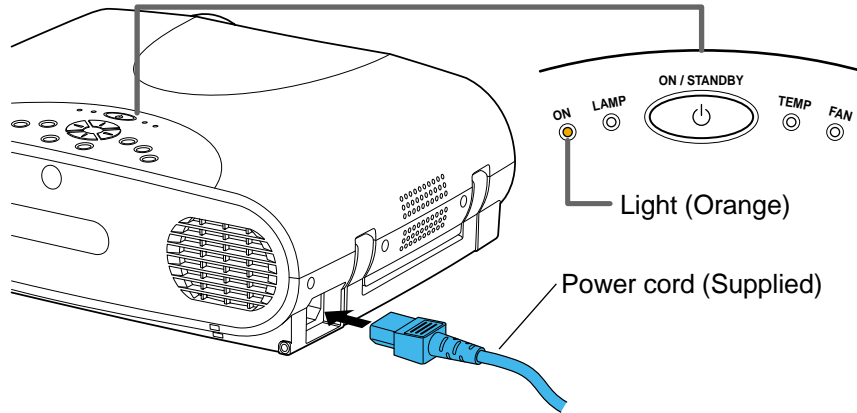

The three indicators, TEMP, LAMP, and ON, light in green for several seconds and then the ON indicator lights in orange and the projector turns to the standby mode.

Do not perform any operations while the three indicators are lit green.

4 Take off the lens cover.

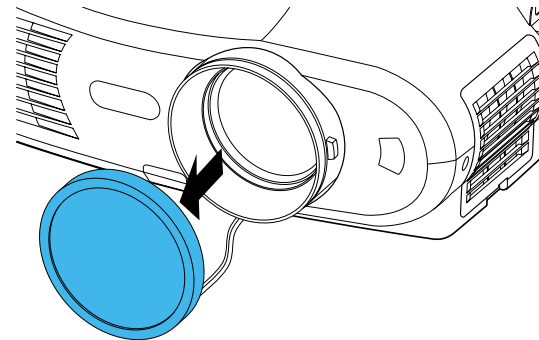

Notes

- When the projector is moved from a cold location to a warm location, or when the ambient temperature in the projection room has risen suddenly, moisture may condense on the lens or the internal optical section to blur the projected pictures. In such a case, leave the projector for an adequate time (1 to 2 hours, depending on the room's condition) before using it, so it adjusts to the ambient temperature.
- If the screen is exposed to direct sunlight or other strong light, the projected picture becomes too faint to see. Shut out the light with curtains or other means.
- If the screen and the projector are not installed properly, the projected picture may be distorted.

Projector placement angle adjustment

The tilt of the projector can be adjusted using the foot adjuster.

1

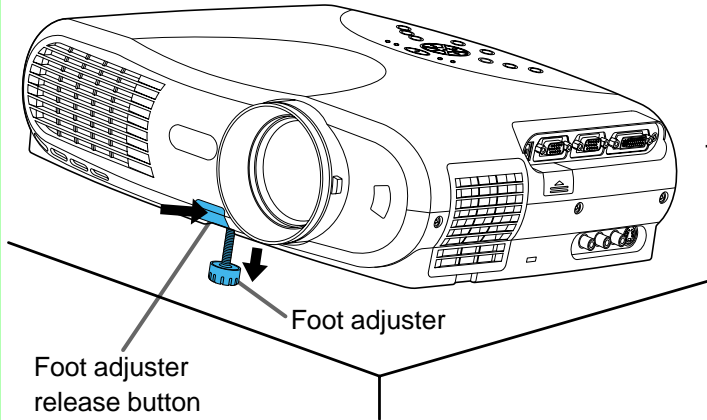

Lift the front of the projector until a tilt angle desired is obtained and hold down the foot adjuster release button.

The foot adjuster will stretch.
Release the button to lock in position.

2

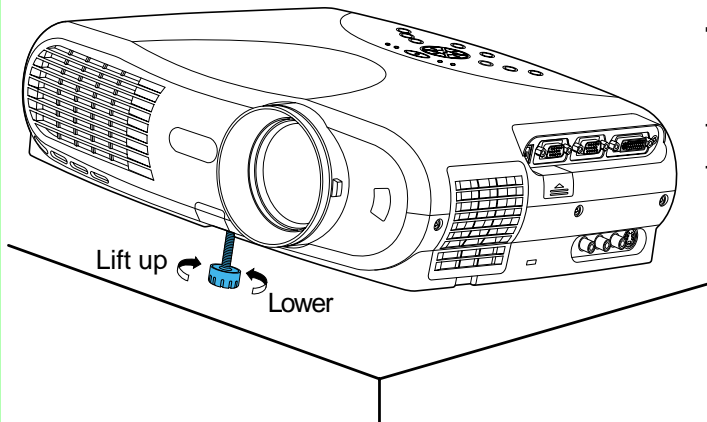

Turn the foot adjuster to make fine adjustment of the height.

Turn clockwise to lift up.
Turn counterclockwise to lower.

Notes

- To put the foot adjuster back, hold down the foot adjuster release button and lower the front slowly.
- Be sure to hold the projector when putting the foot adjuster back so as not to let the front fall on your fingers.
- Do not tilt the projector at an angle exceeding the range adjustable by the foot adjusters, since the duration life of the lamp may be shortened.

Ceiling-mounted projector placement

CAUTION

When a ceiling mount is required, please consult with the dealer.

Ceiling-mounted front projection

Viewing a picture projected on the front of the screen from a ceiling installation.

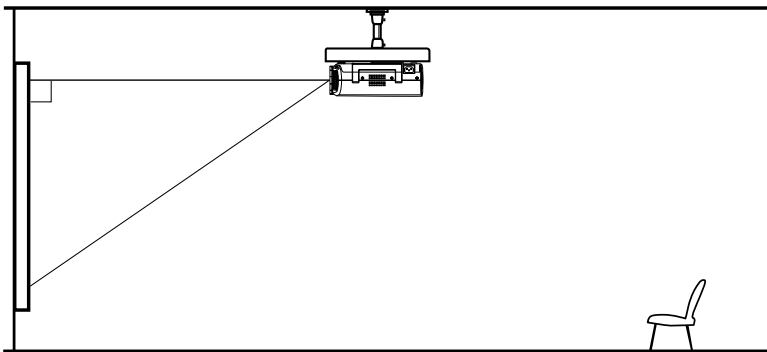

Ceiling-mounted rear projection

Viewing a picture projected through the back of the screen from a ceiling installation.

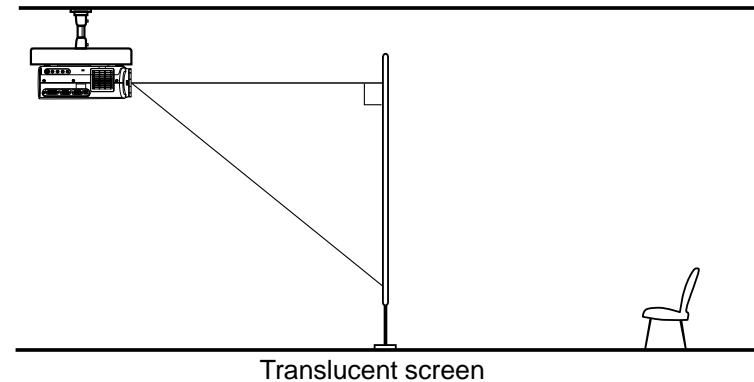

Perform the "Projection mode" setting on the menu screen for the projection method. [51](#)

Note

- The relation between the projection size and the distance to the screen is the same as that of the floor-mounted projection mode. [18](#)

Connecting a computer (COMPUTER IN 1 connector)

You can project the picture from the computer.

Check that the power for the projector and computer is off before connecting the cables.

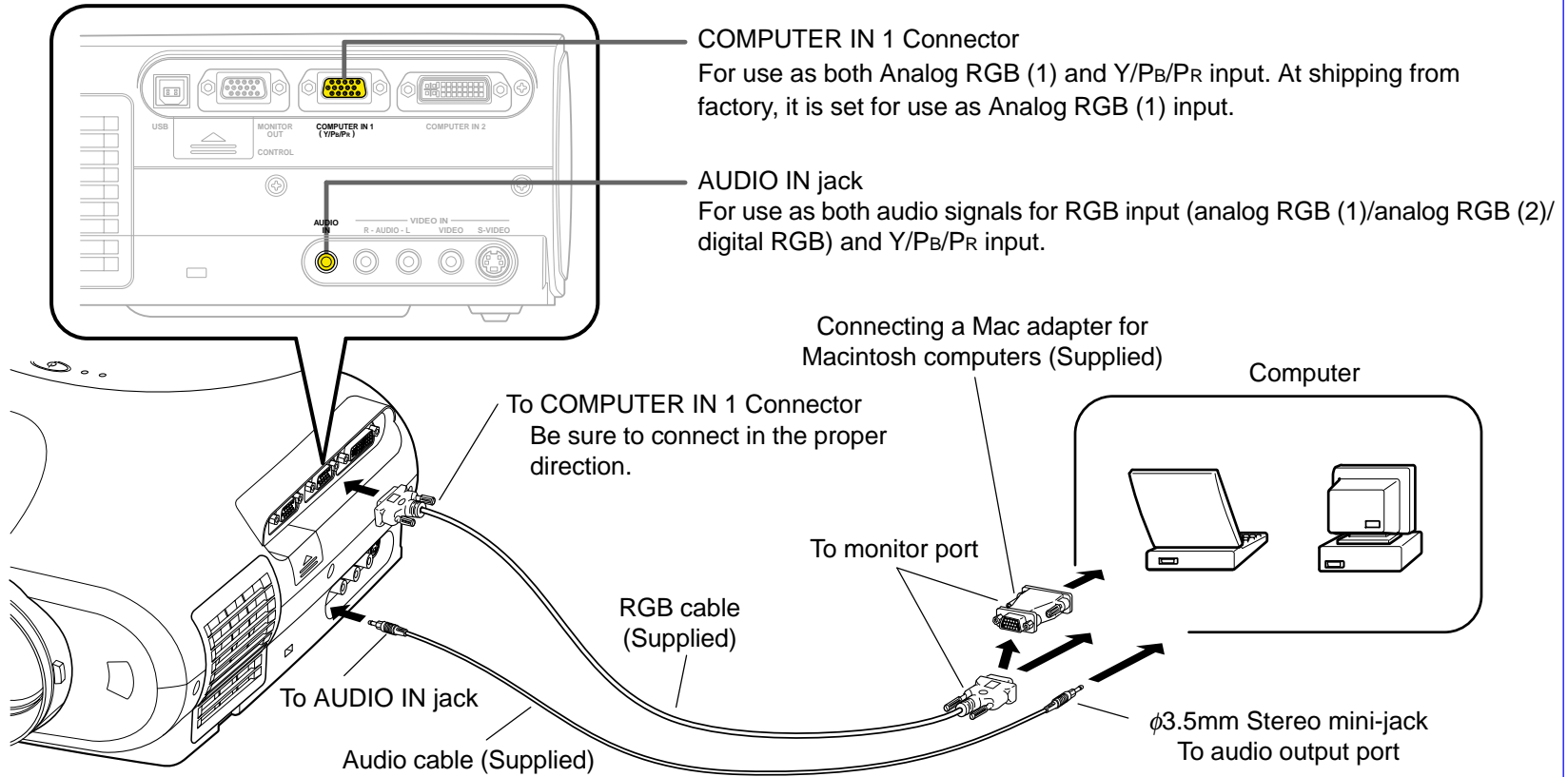

Notes

- The projector cannot be connected to a computer without an analog RGB connector. For details, refer to the computer manual.
- You may not be able to connect some computers to the projector. For details, consult the dealer.
- When connecting to a Macintosh computer, use the supplied Mac adapter (Multiple Scan 21 compatible). For some models the adapter is not required.
- Some computers may have output modes which are not compatible with this projector. Check the compatibility of the connectors, signal levels, timing, resolutions, etc.

Continued

Connecting a computer (COMPUTER IN 2 connector)

You can project the picture of analog RGB or digital RGB signal from a computer by using COMPUTER IN 2 connector. Check that the power for the projector and computer is off before connecting the cables.

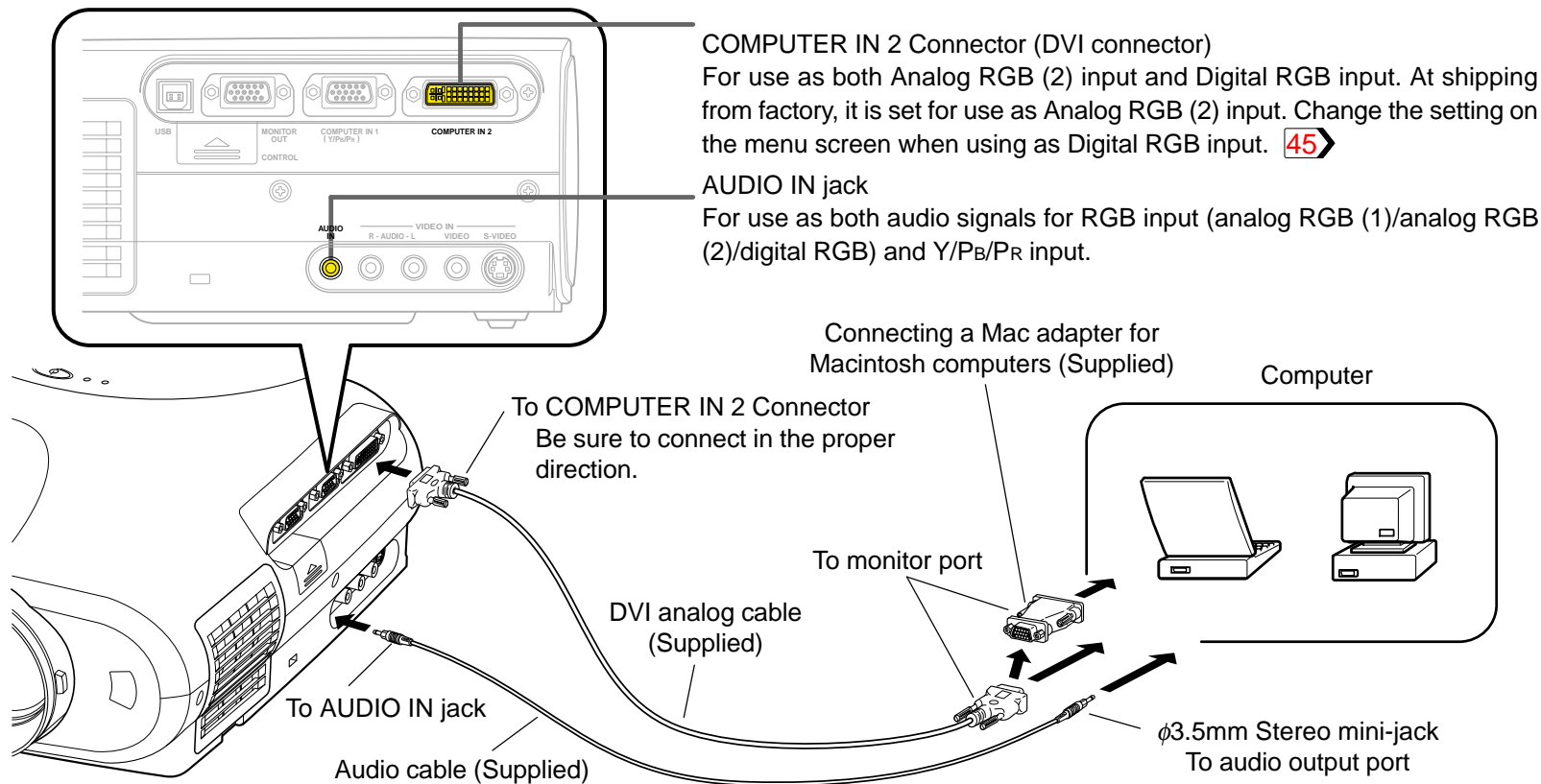

Notes (Please also read "Notes" on page 22.)

- DVI digital cable should be purchased separately when you input a digital RGB signal.
- Although infrequent, noise might be generated on the screen depending on the type of computer and the connection cables. Should this occur, reduce the refresh rate of the computer signal, or lower the resolution. Use of connection cables that are 2 m or shorter is recommended.
- The input signal specifications of the DVI port of the projector conform to DVI 1.0 specifications; however, contents protection is not supported. Note that there is no guaranty of the operations not specified in this specifications.

Continued

Connecting video equipment

You can project the picture from video equipment by using VIDEO IN connectors. Check that the power for the projector and video equipment is off before connecting the cables.

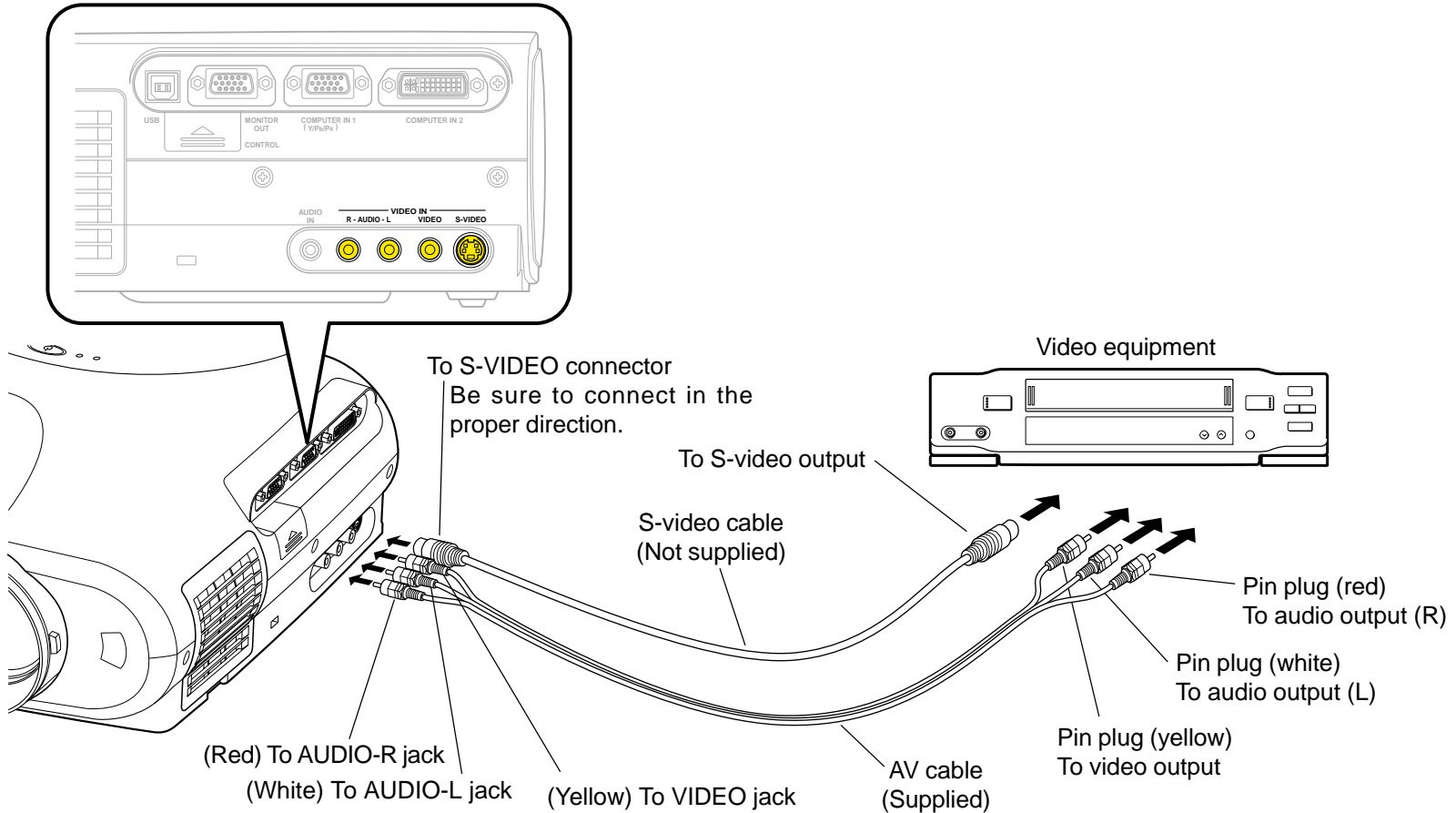

Note

- The S-VIDEO connector and VIDEO jack can be used independently, but the audio input jacks are used as both the S-VIDEO and VIDEO input.

Connecting video equipment (continued)

You can project the picture from video equipment with component video output jack.
Check that the power for the projector and video equipment is off before connecting the cables.

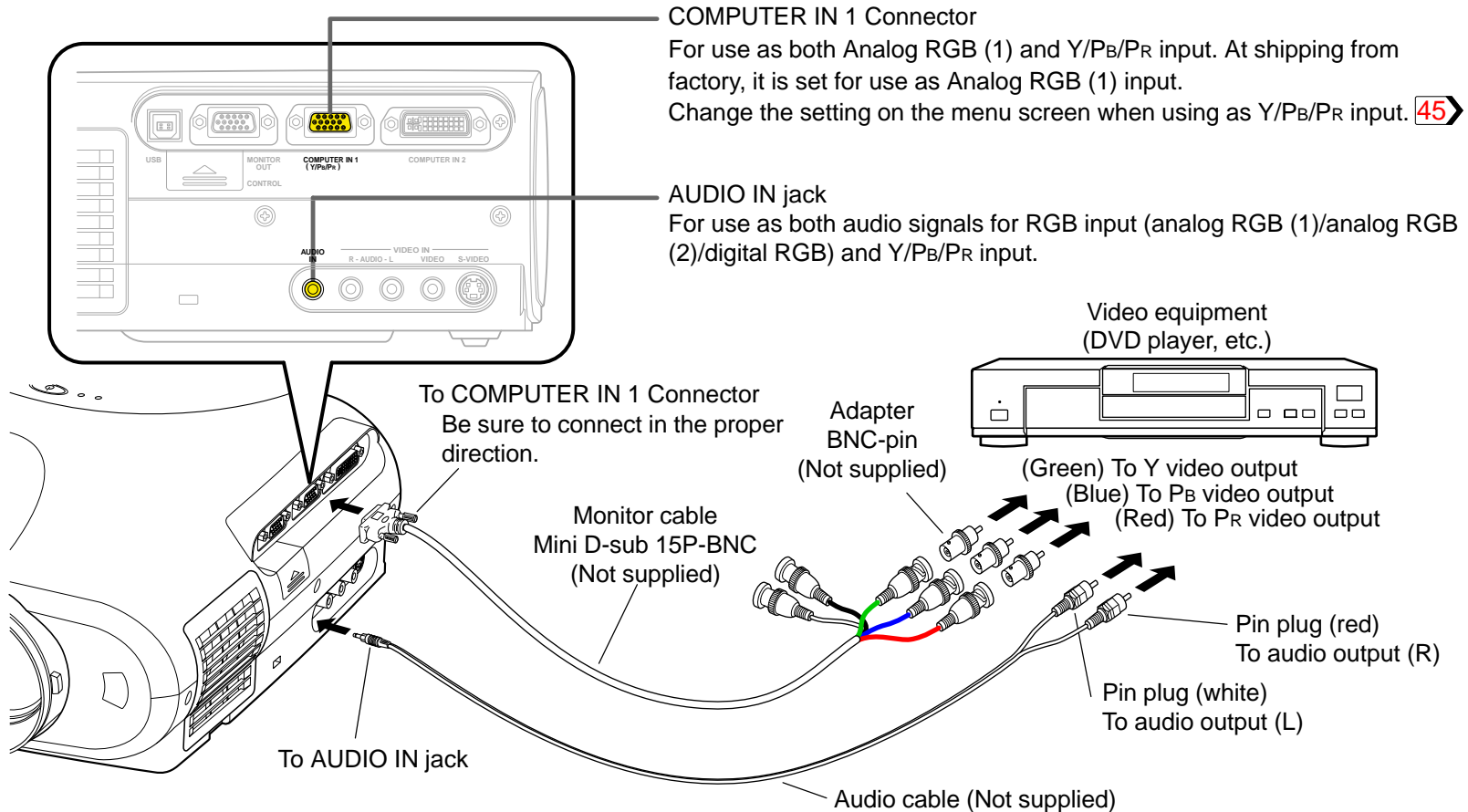

Projector operation control by a computer

You can control the projector by a computer connected with the control cable supplied. **73**
Check that the power for the projector and computer is off before connecting the cables.

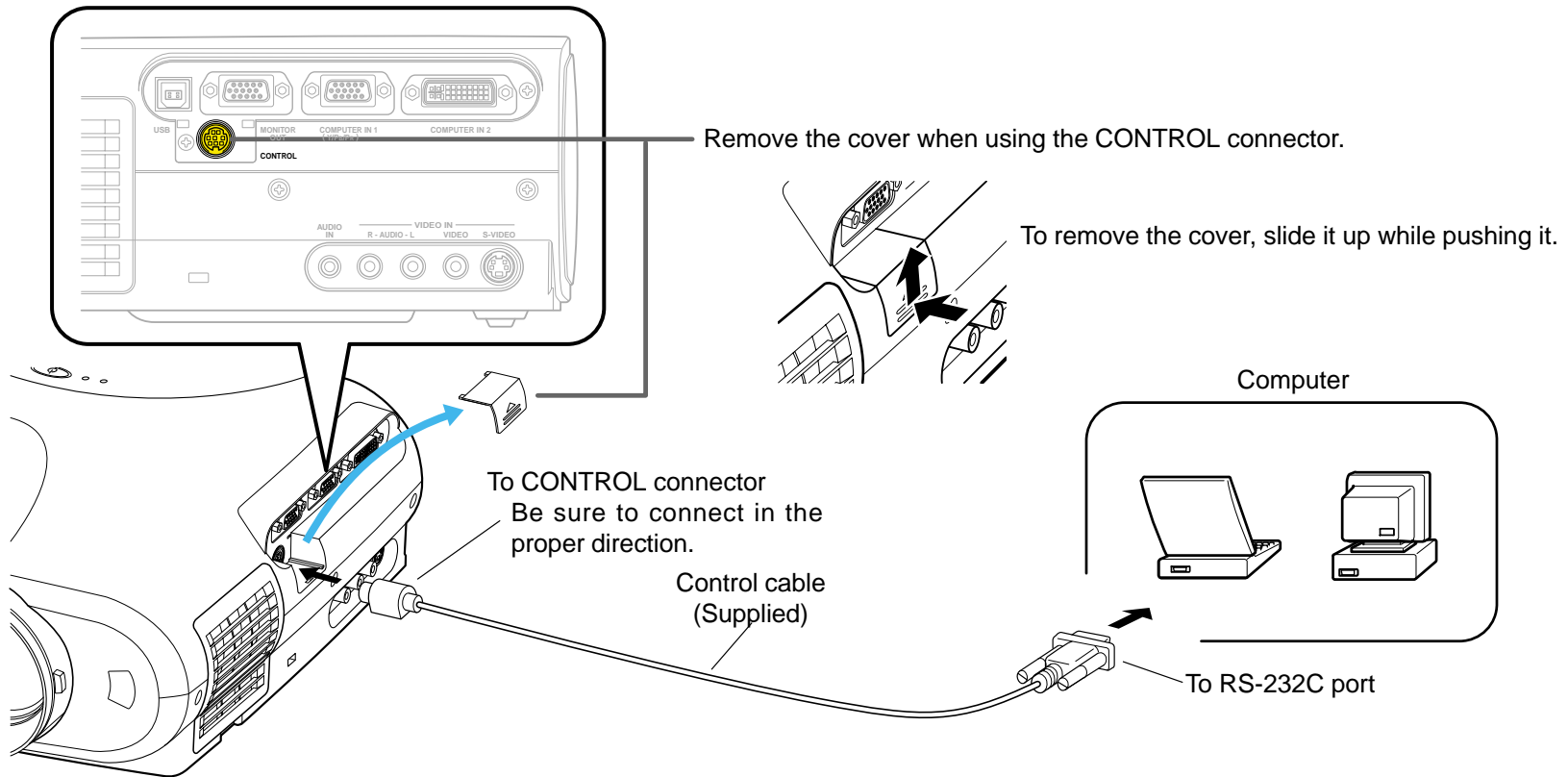

Note

- Do not connect a cable other than the exclusive one supplied.

How to use the output connector

You can output video signal to a computer monitor, etc.

Check that the power for the projector and the equipments is off before connecting the cables.

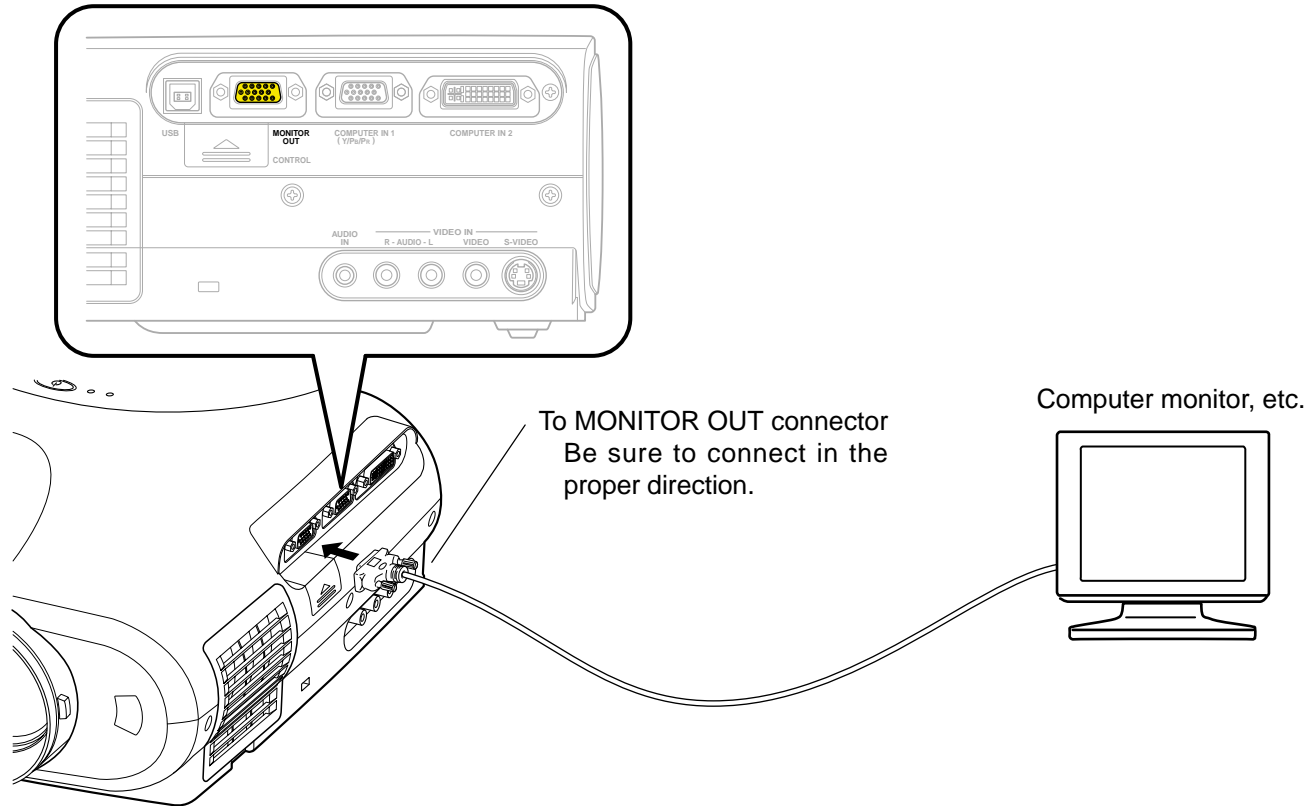

Notes

- The analog RGB signals or Y/P_B/P_R signals of the COMPUTER IN 1 or COMPUTER IN 2 connector selected by the input select operation are output from the MONITOR OUT connector. If neither of these input sources is selected, the signal of the COMPUTER IN 1 connector is output. (Digital RGB signals are not output.)
- Signals are output from the MONITOR OUT connector even when in the standby mode.
- A general computer monitor may not display a normal picture with Y/P_B/P_R signals.

Continued

CAUTION - Do not look into the projection lens while operating the projector.

Remote control

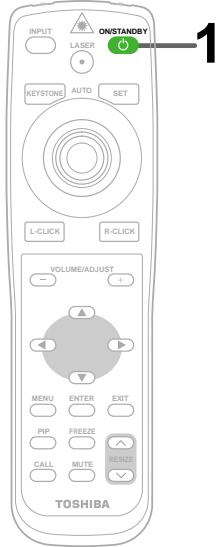

Control panel
(Main unit side)

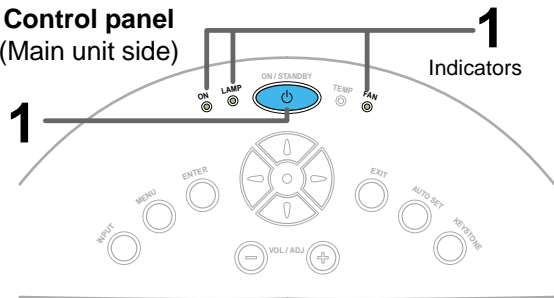

Preparation

- 1 Install and connect the projector properly.
- 2 Take off the lens cover.

1

ON/STANDBY



ON/STANDBY



Press ON/STANDBY.

The projector turns on and the ON, LAMP and FAN indicators light in green.
(The LAMP indicator blinks while the lamp is warming up.)

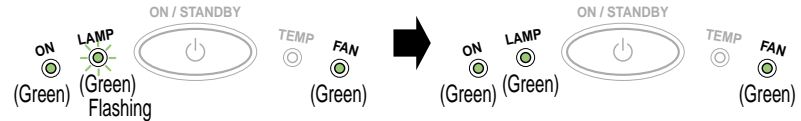

The lamp lights and the startup screen appears.

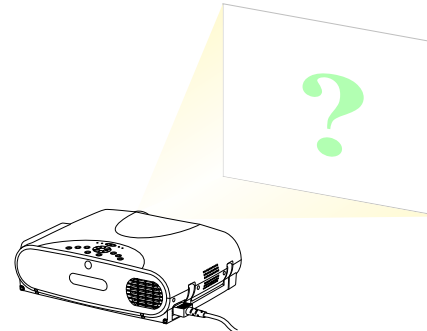

Notes

- The startup screen disappears when you push the **EXIT** button or waited for a while. You can also set the startup screen not to be displayed on the menu screen. **51**
- When a projector is used for the first time, language selection menu is displayed after the startup screen disappears. Set it up with procedures 2 and 3 of the next page.

Remote control

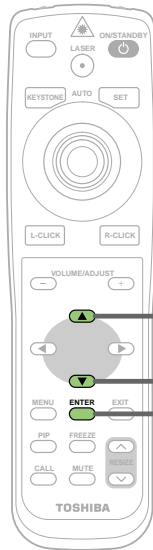

Control panel
(Main unit side)

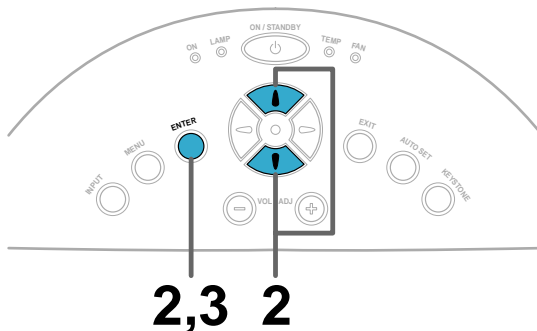

When a projector is used for the first time, the language selection menu, which is to select a language for displaying menus or messages, is displayed. Select a desired language. (At shipping from factory, it is set to English.)

2

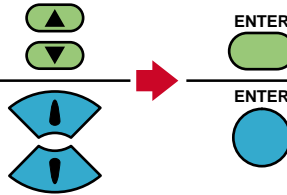

Select a desired language with the selection button (▲/▼), and press ENTER.

A menu confirming the selection result is displayed with the selected language.

3

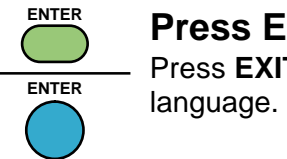

Press ENTER to decide.

Press **EXIT** to return to step 2 when you want to re-select a language.

Notes

- The language selection menu will not be displayed on and after the second time you turn on the power. However, if "Reset all" [52](#) is executed, the language selection menu will be displayed when the power is turned on next time.
- The language can also be selected on the menu screen. [50](#)

4

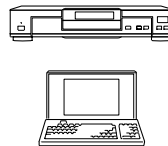

Turn on the connected equipment and put it in playback mode.

Select "Cancel" or install "plug and play monitor" of Windows^(R) when the dialog box of Add New Hardware Wizard screen appears on the computer when connecting a computer.

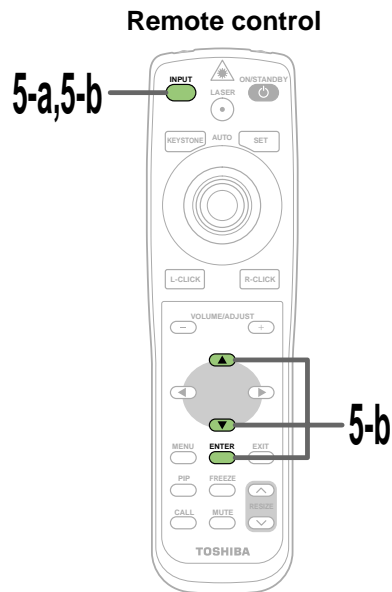

Control panel
(Main unit side)

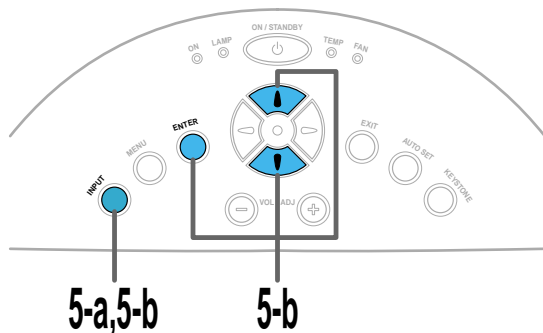

Select the input source to project.
There are two kinds of methods as follows (5-a and 5-b.)

5-a

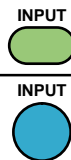

Select the input source by pressing INPUT repeatedly.

At shipping from factory, "Analog RGB(1)" connected to COMPUTER IN 1 connector or "Video" connected to VIDEO Jack can be selected. (You can select "Camera" when using the model with a document imaging camera.)
The icon and the name of the selected input source appear on the screen.

Note

- The types of input sources selected when the **INPUT** button is pressed repeatedly can be set from the menu screen. [45](#)

5-b



Press INPUT and hold for two seconds.

The input source selection menu appears.

Select the input source to project with the selection button (▲/▼).

Regardless of the contents of input source settings on the menu screen, all the input sources are displayed here to be selected.



Press ENTER

A picture of the selected input source is projected.
When a sound signal source is also connected, sound is developed from the speaker.

Notes

(Signal sent from the computer)

- If you project an image from a computer with an LCD screen while monitoring the image on the computer, the image may not be projected properly, depending on the computer model. In this case, turn off the computer display. For details on controlling the computer display, etc., refer to the computer's manual and description on the software for the computer used.
- The projector projects an image by XGA signal (1024 x 768) in full screen.
- The image quality of a computer signal except XGA may deteriorate. It is recommended to set the external monitor connected to the computer to XGA mode (1024 x 768).
- The projector can be also applied to DDC2B (Display Data Channel 2B). If your computer is applied to the DDC, start up your computer after turning on the projector.

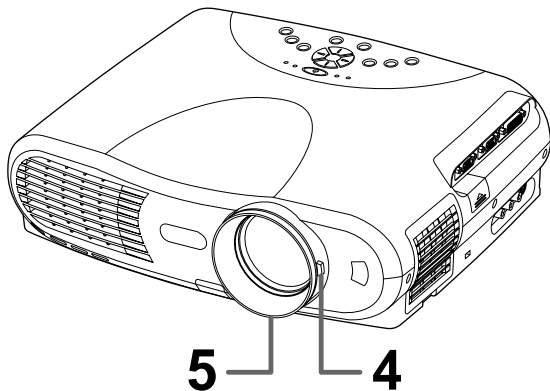
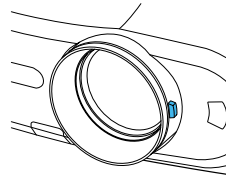
**4**

Adjust the picture size by turning the zooming lever.

Turn to the right to enlarge the picture.
Turn to the left to reduce the picture.

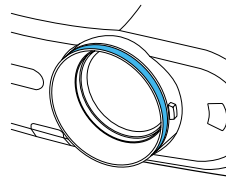
5

Focus on the picture by turning the focusing ring.

A still picture is recommended for focusing.

Remote control

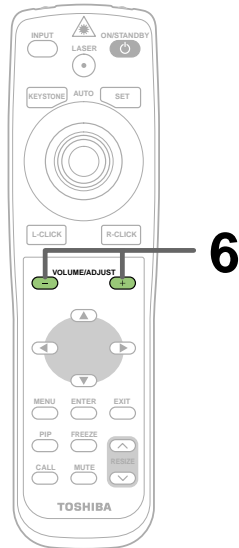

Control panel
(Main unit side)

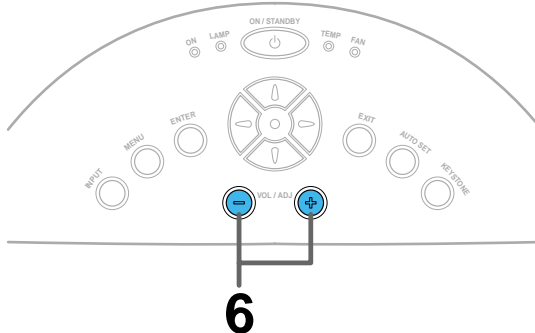

6

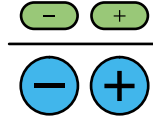

Press VOL/ADJ (+/-) to adjust volume.

Press the (+) button to increase volume.

Press the (-) button to decrease volume.

Notes

- When changing the projecting angle, adjust the foot adjuster. [20](#)
- When the screen image is distorted in keystone, press the **KEYSTONE** button to adjust the distortion. [35](#)
- Due to the lamp characteristic, flickers may occasionally occur in a picture. This is not malfunction of the unit.
- The lamp may rarely burst with a big sound.
- The projector's liquid crystal panel is made using extremely advanced technology, but there may be black spots (pixels that do not light) or bright spots (pixels that are constantly lit) on the panel. Please note that these are not malfunctions.
- When trying to press the button whose operation is not available, the icon  appears.
- When supplying the signal not compatible to the projector, the icon **OFF** appears.
- When signals are not input from the input source, the icon **?** appears.
- The projector may stop operating if the surrounding temperature is too high or if the air filter is clogged with dust. [62](#)

Remote control

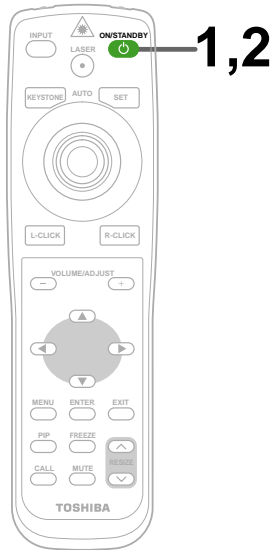

Control panel
(Main unit side)

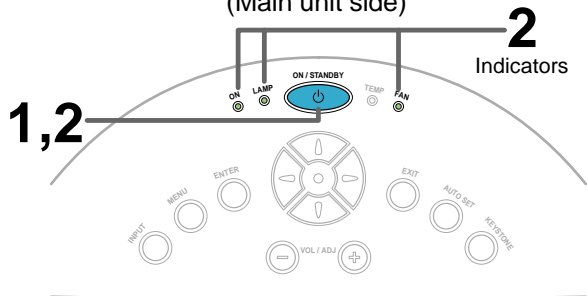

1

ON/STANDBY



ON/STANDBY



Press ON/STANDBY after using the projector.

An instruction message for turning the power off appears on the screen and disappears after a while. When the message disappears, operation becomes invalid.

2

ON/STANDBY



ON/STANDBY



Press ON/STANDBY again.

Cooling starts. Once cooling is completed, the LAMP and FAN indicators turn off and the standby mode is set. (The ON indicator turns in orange.)

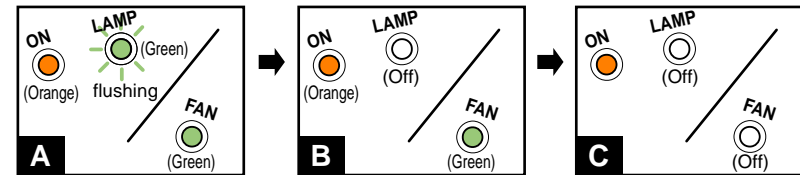

- A** To protect the light source lamp, the LAMP indicator blinks as long as a minimum of cooling is necessary. The power cannot be turned back on during this time. Unplugging the power cord at this time will shorten the lamp's duration life.
- B** The cooling fan continues to run for a while to expel the heat remaining inside. If you are in a hurry, however, you may unplug the power cord at this time.
- C** The standby mode is set.

Notes

- The projector consumes about 20W of power in the standby mode. We recommend you to unplug the power cord when not using the projector for long periods of time.
- Be sure that the LAMP indicator has turned off before unplugging the power cord. Cutting the power by unplugging the power cord while the projector is operating or the light source lamp is being cooled will shorten the lamp's duration life. **Should a fault or some other irregularity arise with this unit, unplug the power cord.**
- When reinserting the power plug before the lamp has cooled, please wait until the lamp has cooled sufficiently before use. When the lamp is at a high temperature, it may not light and the duration life will be shortened.

Remote control

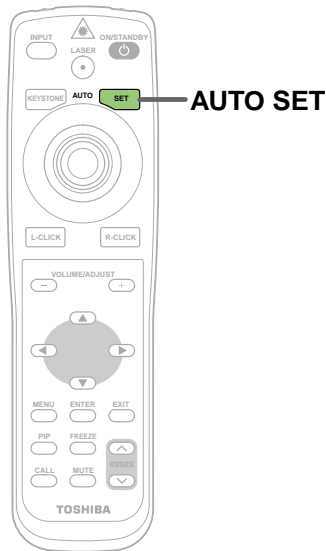

Control panel (Main unit side)

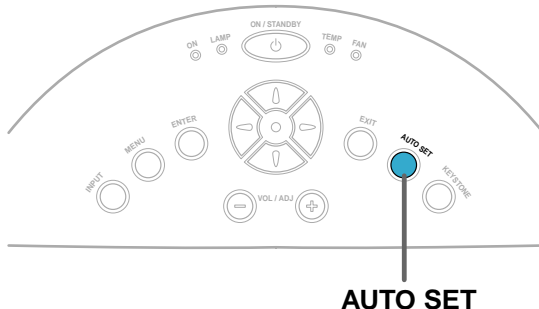

You can adjust the optimum horizontal position, vertical position, sampling phase and sampling frequency for projecting analog RGB signals at the touch of a button.

1

Input full screen video signals from the input source (computer) and project the image.

Adjustments may not be performed properly for images that are not displayed on the entire screen or extremely dark images.

2

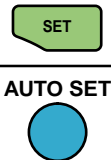

Press AUTO SET.

The horizontal position, vertical position, sampling phase and sampling frequency are adjusted automatically.

The icon  appears during signal processing.

Notes

- Automatic adjustment may not be performed properly for signals other than the computer's signals with which the projector is compatible.
- The horizontal position, vertical position, sampling phase and sampling frequency can also be adjusted from the menu screen. [47](#)

* Sampling frequency

Analog RGB signals input from the computer are converted into digital signals inside the projector. The sampling frequency is the number of times per second the analog signals are converted into digital signals. In order to capture (sample) each individual dot of the computer's signals, the sampling frequency must be adjusted to match the computer's dot clock frequency. If this adjustment is off, details of the image may be blurred, a striped pattern may appear when images with many vertical lines are displayed, or the image's width may change. For computer's signals with which the projector is compatible, the sampling frequency is adjusted automatically even without pressing the **AUTO SET** button.

* Sampling phase

The sampling phase is the timing at which the computer's analog RGB signals are sampled. If the sampling phase is off, the individual dots cannot be sampled at the proper timing, resulting in blurred or flickering images.

Remote control

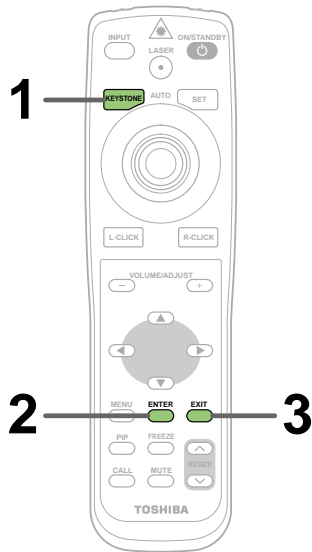

Control panel
(Main unit side)

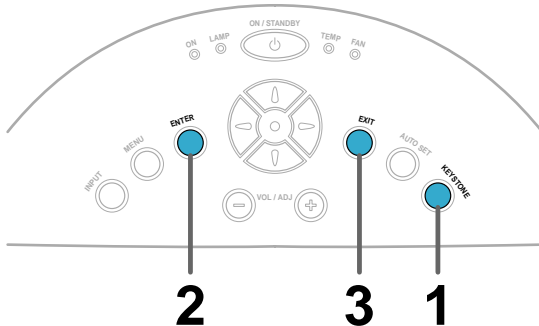

A picture may be expanded on the upper side if projected upward from the projector lifted up by the foot adjuster. The projector can correct this keystone distortion.

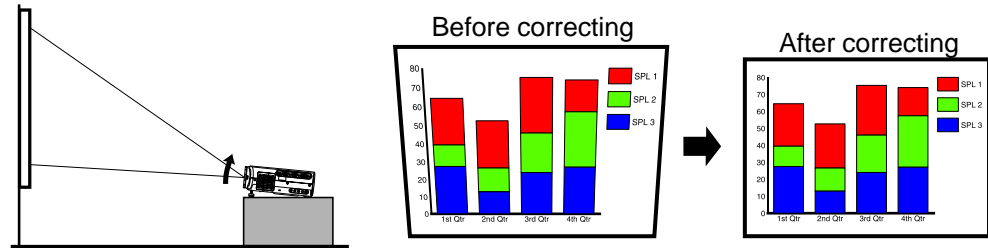

1



Press KEYSTONE

The keystone adjustment menu appears, with the "Auto. V-keystone" being selected. (This menu is the same as the sub-menu which is displayed when "Correct the keystone distortion of the screen" is selected from GUIDE MENU. **45**)

2



Press ENTER

The vertical keystone distortion on the picture projected is automatically corrected.

The icon  appears while the keystone correction is executing.

When the correction is finished, the menu for selecting "V-keystone" or "H-keystone" by manual adjustment appears, with the former being selected.

3



Confirm the keystone distortion

When no more adjustment is needed, press the **EXIT** button repeatedly until the menu disappears.

When the keystone distortion is not corrected properly, adjust it according to the next procedure.

Remote control

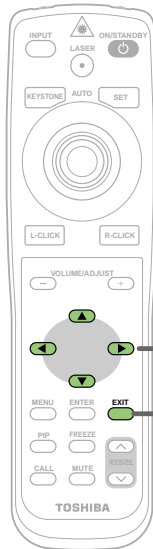

4,5
6

Control panel
(Main unit side)

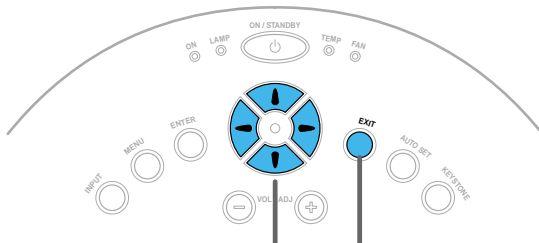

4,5
6

4

When screen is not installed vertically, "Auto. V-keystone" is not corrected properly.



After confirming that "V-keystone" is selected on the menu; **Adjust the distortion of the both sides (right and left) of the picture with the selection button (◀/▶).**

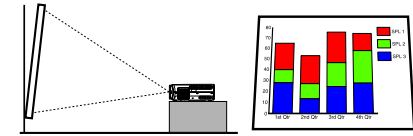

5



When the projector is not installed with the angle of 90 to the screen viewing from the top, the upper and lower sides of the projected picture are distorted.

The angle range of approximately +/-10 to 90 is adjustable.

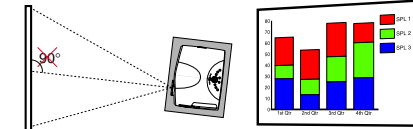

Select "H-keystone" from the menu with the selection button (▲/▼), and adjust the distortion of the upper and lower sides of the picture with the selection button (◀/▶).

6



Press EXIT repeatedly until the menu disappears.
The keystone adjustment finishes.

Notes

- Due to digital correction processing, some of the information may be dropped or the picture quality may be degraded depending on the keystone correction setting or the contents of the signal source.
- The adjustable range of "V-keystone" or "H-keystone" is influenced by the quantity of correction of each other.
- When "Auto. V-keystone" does not operate properly even with the screen installed vertically, execute "H-reference reset" [52].

Remote control

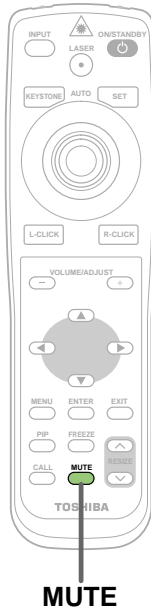

The image and sound of this projector can be turned off if you wish to temporarily project the image of another projector or a OHP, etc., on the screen.



Press MUTE.

The sound and picture are cut off temporarily. To cancel the mute mode, press MUTE again. The image and sound will be output.

The icon  appears in the mute mode.

Note

- The mute mode is cancelled if another operation is performed during the mute mode.

Remote control

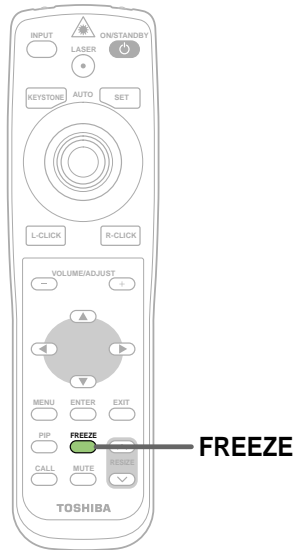

You can freeze the image being projected.
Use this function to stop images from a video recorder to make presentations.



Press **FREEZE**.

The picture freezes.

To release the picture, press **FREEZE** again.

The icon  appears in the freeze mode.

Notes

- The frozen image can be enlarged with the **RESIZE** button. The freeze mode is cancelled if any operation other than **RESIZE** is performed.
- The freeze mode cannot be set when there is no input (when no signals are being supplied from a signal source).
- The input source's image continues to play even when the projector is set to the freeze mode.

Remote control

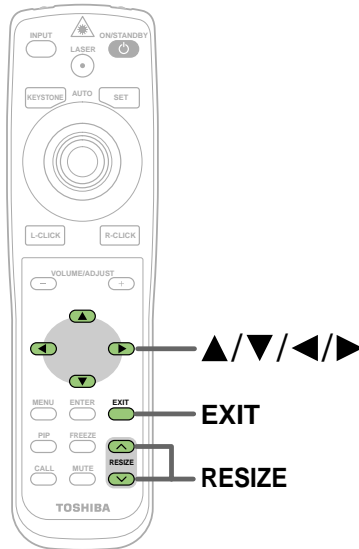

The icon  appears in the resize mode.

You can enlarge (resize) the picture size projected.



Press RESIZE (^).

The enlargement ratio increases each time the **RESIZE (^)** button is pressed. The enlargement ratio can be increased continuously by keeping the button pressed in.

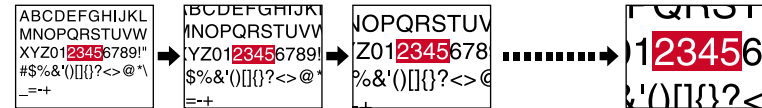

To reduce the enlargement ratio, press the **RESIZE (v)** button. The enlargement ratio can be reduced continuously by keeping the button pressed in.

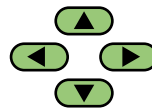
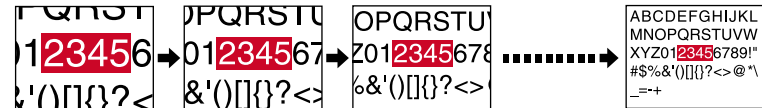

The enlarged section is moved when the selection buttons (**▲/▼/◀/▶**) are pressed. The section can be moved continuously by keeping the button pressed in.



Press the **EXIT** button to cancel the resize mode and return to the original size.

Notes

- Enlarged images can be frozen by pressing the **FREEZE** button. The images frozen also can be enlarged or reduced.
- The resize mode is cancelled if any operation other than setting the freeze mode is performed.
- This projector uses electrical digital resizing, so the picture quality degrades when images are enlarged.
- In rare cases, the picture may be disturbed while the magnification section is being moved.
- With some signals, the image cannot be enlarged.
- This function does not work in no input status (no signal is supplied from the signal source).

Remote control

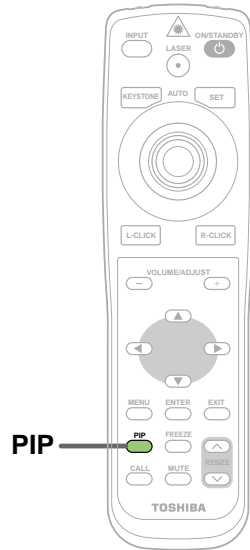

Video or S-video images can be displayed as small images on the computer's image. (Referred to as "sub-pictures" in this manual.)



Press PIP.

A sub-picture is displayed.

Press the **PIP** button again to turn off the sub-picture.

Notes

- The PIP function cannot be used when a source other than an RGB input source is selected.
- The PIP function cannot be used with no signals supplied from an RGB signal source.
- The sub-picture turns off if any other operation is performed.
- The signal source, size, display position and audio input source to display sub-pictures can be changed from the menu screen. [53](#)

Remote control

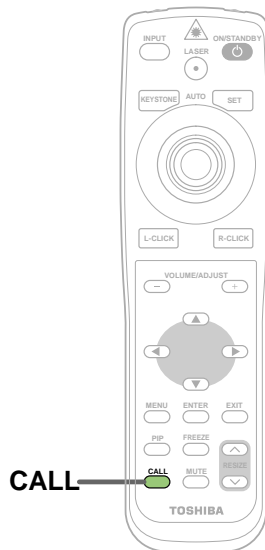

Information on the input signal source, etc., can be displayed.



Press CALL.

The information described below is displayed.

The information display turns off when the **CALL** button is pressed again.



Status display

Input	- current input source
H-resolution	- the horizontal resolution of the input signal (at RGB input)
V-resolution	- the vertical resolution of the input signal (at RGB input)
H-frequency	- the horizontal frequency of the input signal (at RGB input)
V-frequency	- the vertical frequency of the input signal (at RGB input)
Sync	- the polarity of the sync signal (at RGB input)
Video mode	- the color mode of the video signal (at Video, S-Video input)
Signal format	- the formatting of the Y/P _B /P _R signal (at Y/P _B /P _R input)
Lamp time	- the elapsed using time of the lamp
Version	- the version of the firmware
Shutter	- the shutter speed of the document imaging camera (at document imaging camera input)

Notes

- The information displayed is not refreshed even if it changes. To refresh the information, turn off the information display, then turn it back on.
- The information display turns off if any other operation is performed.
- The "Lamp time" shows an approximate time for lamp replacement. (It should not be used as a lamp warranty time counter.) If the time indicated here nears 1000, contact your store of purchase about obtaining a replacement lamp (TLPL78, sold separately).
- The "Lamp time" can be reset when the lamp is replaced.
- The "Version" is the version of the control program used in the projector and is used for servicing, etc.

Operating a computer by the remote control

You can control a computer by the remote control when the projector and computer are connected with the supplied USB cable. In this manual, this function is explained as "mouse remote control".

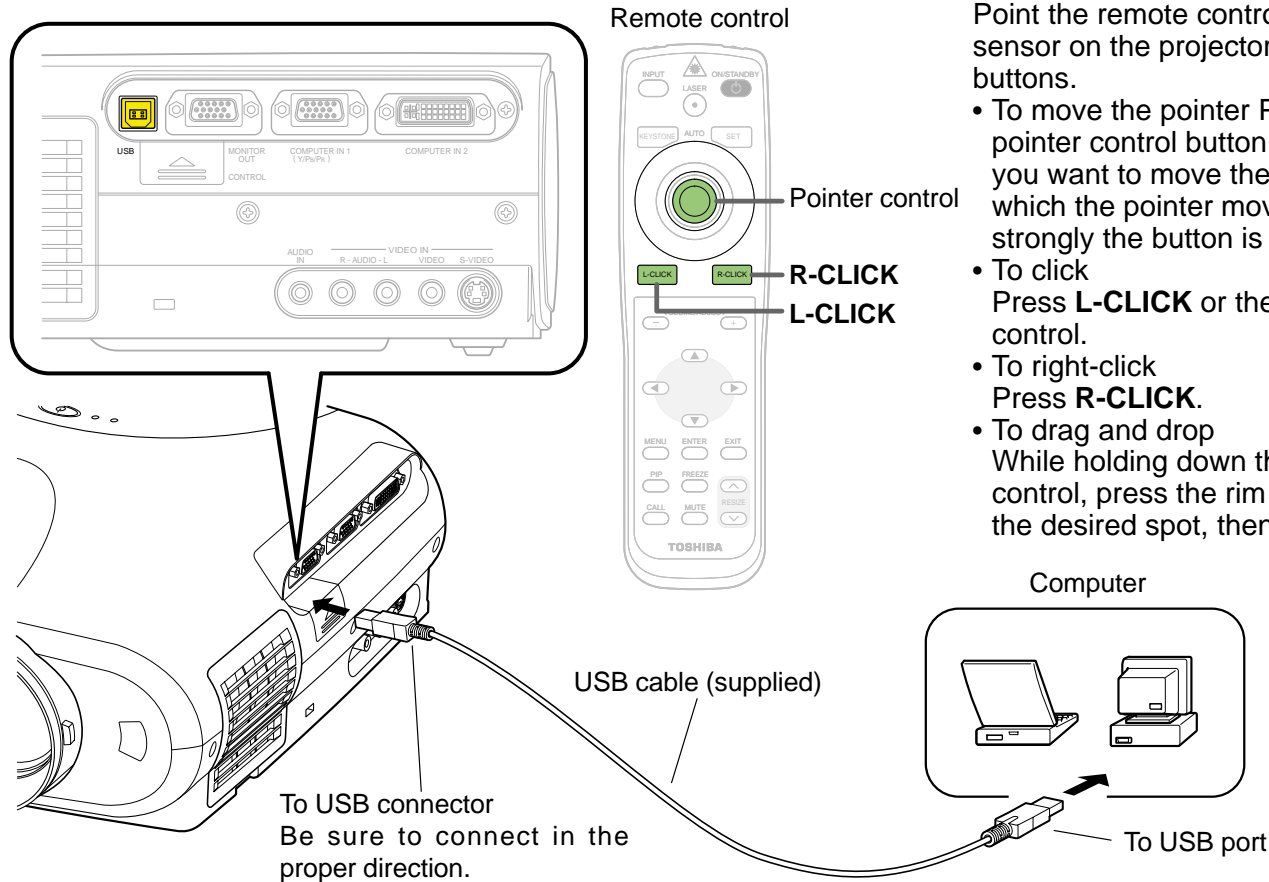

Point the remote control at the remote control sensor on the projector when operating with its buttons.

- To move the pointer Press the outer side of the pointer control button in the direction in which you want to move the pointer. (The speed at which the pointer moves depends on how strongly the button is pressed.)
- To click Press **L-CLICK** or the center of the pointer control.
- To right-click Press **R-CLICK**.
- To drag and drop While holding down the center of the pointer control, press the rim side to move the pointer to the desired spot, then release the center part.

Notes

- This function is available with Windows98 and Mac OS9 computers equipped with a USB port as standard.
- When connecting the computer's USB port for the first time, a message asking you to insert the Windows98 CD-ROM may appear on the computer's monitor screen, depending on whether or not the device driver is installed. If so, do as the message says.
- When using a USB cable other than the supplied one, be sure to use a shielded type.

Operating the menu screen

Various adjustments and settings can be made on the menu screen. The basic operation on the menu screen is shown here.

Start **GUIDE MENU:** You can adjust or set the functions used frequently.

Press MENU.
Then GUIDE MENU appears, and a list of several items is displayed in the menu.
The current input source →
Items →
Button operation guide →

When you make more detailed adjustments and settings, call the FULL MENU.
Return to the GUIDE MENU when the MENU button is pressed.

FULL MENU: For the operating instruction, refer to the next page. **44**

Press MENU button once again.
The FULL MENU of [Picture] appears.
FULL MENU has seven pages of [Picture], [Position], [Color], [Audio], [Display], [Default setting] and [Reset].
Use the selection button (◀/▶) to change the page of FULL MENU.

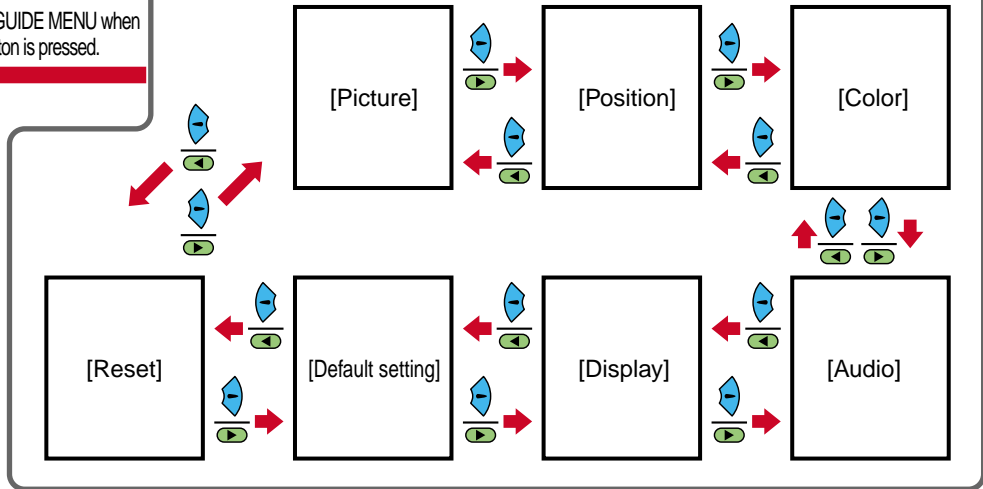

Select the item with the selection button (▲/▼).

Press ENTER to decide.
The item selected can be adjusted or set.

Adjust and set it with the button indicated on the button operation guide.
According to the selected item, the kind ([adjustment],[setting] or [execution]) and the button to be used are indicated on the button operation guide.

Press EXIT and return.
When you select other items, press EXIT repeatedly until GUIDE MENU appears.
When you want to quit, press EXIT repeatedly until GUIDE MENU disappears.

End

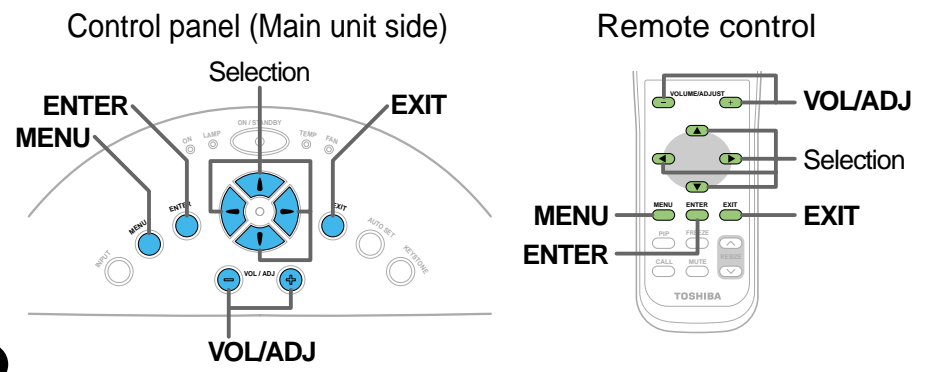

Operating the menu screen (continued)

Start For the selection method of FULL MENU, refer to the previous page. **43**

Select the item with selection buttons (▲/▼).
 State of a figure below is a sample for explanation.
 This state does not in fact.

The current input source
 Kind (page) of FULL MENU
 Items
 Adjustment display bar
 Setting objects
 Button operation guide

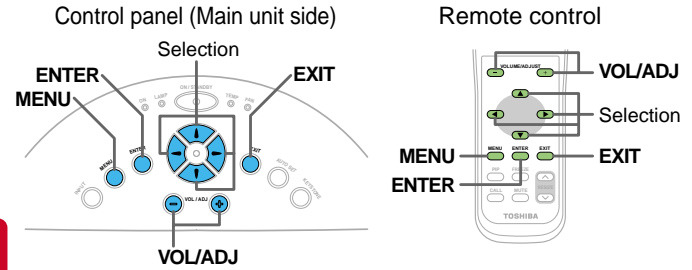

At the item where the adjustment bar is displayed;

At the item where the setting objects are displayed on sub menu;

At the item where [Execution] is displayed on the operation guide;

Press ENTER.
 The Item selected is executed. FULL MENU is displayed after execution.

Press ENTER.
 An object can be selected from the sub menu list.

Press ENTER.
 Only the (small list of the) selected adjusting items is displayed. This is useful as you can see a main picture not hidden under FULL MENU.

Select it with the button indicated on the button operation guide.

Adjust with VOL/ADJ (+/-) or selection buttons (◀/▶).

Press EXIT.
 FULL MENU is displayed and you can select other items.

Press EXIT.
 FULL MENU disappears, and adjustment or setting is finished.

End

Note

- An exclusive menu is displayed when making PIP function sub-picture settings. **53**

GUIDE MENU adjustments and settings

On GUIDE MENU, you can set or adjust the functions frequently used.
To operate GUIDE MENU, refer to page 43.

				The relationship between input source and item Yes: Adjustable - : Not displayed								
				Analog RGB(1)	Analog RGB(2)	Digital RGB	Y/Pb/Pr	Video	S-Video	Camera		
Adjust the image brightness.	Contrast	ADJ.	Adjusting contrast of the picture	Yes	Yes	Yes	Yes	Yes	Yes	Yes		
	Brightness	ADJ.	Adjusting brightness of the picture									
Adjust the image flicker.	Phase	ADJ.	Adjusting flicker of the picture (sampling clock phase adjustment)	Yes	Yes	-	-	-	-	-		
Adjust the image color.	Color	ADJ.	Adjusting color deepness of the picture	-	-	-	Yes	Yes	Yes	-		
Adjust the gain of the document imaging camera.	Camera gain	ADJ.	Adjusting the document imaging camera's gain	-	-	-	-	-	-	Yes		
Reduce the flicker.	Shutter		Select it from follows so that flickering of the document imaging camera's picture decreases									
	Auto	SET	The shutter speed is set automatically	-	-	-	-	-	-	Yes		
	50Hz	SET	The shutter speed is fixed to 50 Hz									
	60Hz	SET	The shutter speed is fixed to 60 Hz									
Select the image with its brightness priority or quality (color) priority.	Bright	SET	Priority is given to brighter picture	Yes	Yes	Yes	-	-	-	-		
	True color	SET	Priority is given to the true color of the picture									
Correct the keystone distortion of the screen.	Auto. V-keystone	EXEC.	The vertical keystone distortion is adjusted automatically	Yes (common for all of the inputs)								
	To manual adjustment	EXEC.	V-keystone								ADJ.	Adjusting the Vertical keystone
			H-keystone								ADJ.	Adjusting the Horizontal keystone
Select the input source when changing the input.	COMPUTER IN 1	SET	<input checked="" type="checkbox"/> : COMPUTER IN 1 connector is selectable by INPUT button	Yes (common for all of the inputs)								
	Analog RGB(1)	SET	<input type="checkbox"/> : Use COMPUTER IN 1 connector as Analog RGB(1) input									
	Y/Pb/Pr	SET	<input type="checkbox"/> : Use COMPUTER IN 1 connector as Y/Pb/Pr input									
	COMPUTER IN 2	SET	<input checked="" type="checkbox"/> : COMPUTER IN 2 connector is selectable by INPUT button									
	Analog RGB(2)	SET	<input type="checkbox"/> : Use COMPUTER IN 2 connector as Analog RGB(2) input									
	Digital RGB	SET	<input type="checkbox"/> : Use COMPUTER IN 2 connector as Digital RGB input									
	VIDEO	SET	<input checked="" type="checkbox"/> : Video input is selectable by INPUT button									
	S-VIDEO	SET	<input checked="" type="checkbox"/> : S-Video input is selectable by INPUT button									
	CAMERA	SET	<input checked="" type="checkbox"/> : Camera input is selectable by INPUT button									

- : On/Off with **ENTER**
- : On/Off with (+) or (-)

Notes

- The items related to the camera (the document imaging camera) are displayed only with a model having the camera.
- "Sampling phase" is to be adjusted and memorized for each RGB signal 71.
- "Keystone" and "Input source setting" can be adjusted (set) at all input sources, but the adjustments (settings) made at one input source are applied to all input sources.
- It is impossible to exit from the menu if no input source is selected.
- If the check in the check box for the currently selected source is removed, the setting becomes effective the next time the input is changed.
- The adjustments or settings made are memorized automatically when the power is turned off by pressing the **ON/STANDBY** button. If the power cord is unplugged or if a power failure occurs while the projector is on, the adjustments or settings are not memorized.

FULL MENU adjustments and settings - Picture

You can adjust various items of the picture from FULL MENU [Picture].

To operate FULL MENU, refer to page [44](#).

				The relationship between input source and item Yes: Adjustable - : Not displayed						
				Analog RGB(1)	Analog RGB(2)	Digital RGB	Y/P _B /P _R	Video	S-Video	Camera
Contrast	ADJ.	Adjusting contrast of the picture		Yes	Yes	Yes	Yes	Yes	Yes	Yes
Brightness	ADJ.	Adjusting brightness of the picture		Yes	Yes	Yes	Yes	Yes	Yes	Yes
Sharpness	ADJ.	Adjusting sharpness of the picture (This item is setting instead of adjustment at Y/P _B /P _R input.)		-	-	-	Yes	Yes	Yes	Yes
Camera gain	ADJ.	Adjusting the document imaging camera's gain		-	-	-	-	-	-	Yes
Picture mode	Bright	SET	Priority is given to brighter picture	Yes	Yes	Yes	-	-	-	-
	True color	SET	Priority is given to the true color of the picture	-	-	-	-	-	-	-
Video mode	Auto	SET	The video mode (color system) is set automatically	-	-	-	-	-	-	-
	NTSC	SET	The video mode is fixed to NTSC system	-	-	-	-	-	-	-
	PAL	SET	The video mode is fixed to PAL system	-	-	-	-	-	-	-
	SECAM	SET	The video mode is fixed to SECAM system	-	-	-	-	Yes	Yes	-
	PAL-N	SET	The video mode is fixed to PAL-N system	-	-	-	-	-	-	-
	PAL-M	SET	The video mode is fixed to PAL-M system	-	-	-	-	-	-	-
	PAL-60	SET	The video mode is fixed to PAL-60 system	-	-	-	-	-	-	-
NTSC-4.43	SET	The video mode is fixed to NTSC-4.43 system	-	-	-	-	-	-	-	
Signal format	Auto	SET	The Y/P _B /P _R signal format is set automatically	-	-	-	-	-	-	-
	525i	SET	The Y/P _B /P _R signal format is fixed to 525i mode	-	-	-	-	-	-	-
	525p	SET	The Y/P _B /P _R signal format is fixed to 525p mode	-	-	-	-	-	-	-
	625i	SET	The Y/P _B /P _R signal format is fixed to 625i mode	-	-	-	Yes	-	-	-
	750p	SET	The Y/P _B /P _R signal format is fixed to 750p mode	-	-	-	-	-	-	-
	1125i	SET	The Y/P _B /P _R signal format is fixed to 1125i mode	-	-	-	-	-	-	-
Shutter	Auto	SET	The shutter speed is set automatically	-	-	-	-	-	-	-
	50Hz	SET	The shutter speed is fixed to 50 Hz	-	-	-	-	-	-	Yes
	60Hz	SET	The shutter speed is fixed to 60 Hz	-	-	-	-	-	-	-
Screen size	Full	SET	The picture is converted to XGA (1024 x 768 dot) resolution	Yes	Yes	Yes	Yes	Yes	Yes	Yes
	thru	SET	The picture is displayed with the input resolution	-	-	-	-	-	-	-
	Wide	SET	The picture is converted to the wide screen picture	-	-	-	Yes	Yes	Yes	-
Overlay gain	ADJ.	Adjusting the level of the overwriting picture using the document imaging camera		Yes	Yes	Yes	Yes	Yes	Yes	-
Reset	EXEC.	The adjustments and settings of FULL MENU [Picture] are returned to the factory default setting		Yes	Yes	Yes	Yes	Yes	Yes	Yes

Notes

- The items related to the camera are indicated only with a model having the camera.
- A part of function is restricted if the object other than [Auto] is selected in "Video mode" or "Signal format". [51](#)
- The adjustments or settings made are memorized automatically when the power is turned off by pressing the **ON/STANDBY** button. If the power cord is unplugged or if a power failure occurs while the projector is on, the adjustments or settings are not memorized.

FULL MENU adjustments - Position

You can adjust the picture position etc. of analog RGB input from FULL MENU [Position].
To operate FULL MENU, refer to page [44](#) .

			The relationship between input source and item Yes: Adjustable - : Not displayed						
			Analog RGB(1)	Analog RGB(2)	Digital RGB	Y/P _B /P _R	Video	S-Video	Camera
H-position	ADJ.	Adjusting the horizontal display position of the picture	Yes	Yes	-	-	-	-	-
V-position	ADJ.	Adjusting the vertical display position of the picture	Yes	Yes	-	-	-	-	-
Phase	ADJ.	Adjusting flicker of the picture (sampling clock phase adjustment)	Yes	Yes	-	-	-	-	-
Frequency	ADJ.	Adjusting the sampling frequency of the input signal	Yes	Yes	-	-	-	-	-
Reset	EXEC.	The adjustments of FULL MENU [Position] are returned to the factory default value	Yes	Yes	-	-	-	-	-

Notes

- This menu is not displayed except analog RGB input.
- The adjustment of each item in this menu is memorized for each RGB signal input [71](#) .
- The adjustments made are memorized automatically when the power is turned off by pressing the **ON/STANDBY** button. If the power cord is unplugged or if a power failure occurs while the projector is on, the adjustments are not memorized.

FULL MENU adjustments - Color

You can adjust the color condition of the picture from FULL MENU [Color].
 To operate FULL MENU, refer to page 44.

The relationship between input source and item							Yes: Adjustable - : Not displayed		
Analog RGB(1)	Analog RGB(2)	Digital RGB	Y/P _B /P _R	Video	S-Video	Camera			

Color	ADJ.	Adjusting color deepness of the picture	-	-	-	Yes	Yes	Yes	-
Tint	ADJ.	Adjusting tint of the picture (not adjustable at PAL, SECAM, PAL-N, PAL-M and PAL60)	-	-	-	-	Yes	Yes	-
R-level	ADJ.	Adjusting red's color level of the picture	Yes	Yes	Yes	Yes	Yes	Yes	Yes
G-level	ADJ.	Adjusting green's color level of the picture	Yes	Yes	Yes	Yes	Yes	Yes	Yes
B-level	ADJ.	Adjusting blue's color level of the picture	Yes	Yes	Yes	Yes	Yes	Yes	Yes
Reset	EXEC.	The adjustments of FULL MENU [Color] are returned to the factory default value	Yes	Yes	Yes	Yes	Yes	Yes	Yes

Notes

- The adjustments made are memorized automatically when the power is turned off by pressing the **ON/STANDBY** button. If the power cord is unplugged or if a power failure occurs while the projector is on, the adjustments are not memorized.

FULL MENU adjustments and settings - Audio

You can set the sound developed from the speaker from FULL MENU [Audio].
To operate FULL MENU, refer to page 44.

				The relationship between input source and item						
				Yes: Adjustable - : Not displayed						
				Analog RGB(1)	Analog RGB(2)	Digital RGB	Y/P _B /P _R	Video	S-Video	Camera
Volume	ADJ.	Adjusting the sound volume developed from speaker		Yes	Yes	Yes	Yes	Yes	Yes	-
Speaker output	On	SET	The sound is developed from the speakers	Yes (common)				Yes (common)		-
	Off	SET	No sound is developed from the speakers							
Channel select	L+R	SET	The sound of the left and right channels is mixed and developed from the speaker	Yes (common)				Yes (common)		-
	L	SET	Only the sound of the left input channel is developed from the speaker							
	R	SET	Only the sound of the right channel is developed from the speaker							
Loudness	On	SET	The loudness effect is added to the speaker sound	Yes (common)				Yes (common)		-
	Off	SET	The loudness effect is not added to the speaker sound							
Reset	EXEC.	The adjustments and settings of FULL MENU [Audio] are returned to the factory default setting		Yes (common)				Yes (common)		-

Notes

- When the camera input is selected, the sound is not developed.
- Each item can be set at every input sources except the camera input, but the settings made at one input source are applied to all input sources as shown in the table. The sound volume can be adjusted for each input source except the camera input.
- The adjustments or settings made are memorized automatically when the power is turned off by pressing the **ON/STANDBY** button. If the power cord is unplugged or if a power failure occurs while the projector is on, the adjustments or settings are not memorized.

FULL MENU adjustments and settings - Display

You can set the language, menu display, etc. from FULL MENU [Display].
To operate FULL MENU, refer to page 44.

				The relationship between input source and item Yes: Adjustable -: Not displayed						
				Analog RGB(1)	Analog RGB(2)	Digital RGB	Y/Pb/Pr	Video	S-Video	Camera
V-keystone	ADJ.	Adjusting the keystone distortion when having changed the vertical installation angle		Yes (common for all of the inputs)						
H-keystone	ADJ.	Adjusting the keystone distortion when having changed the horizontal installation angle		Yes (common for all of the inputs)						
Language		English	SET	The language is set to English for menu and message displayed		Yes (common for all of the inputs)				
		Français	SET	The language is set to French for menu and message displayed						
		Deutsch	SET	The language is set to German for menu and message displayed						
		Italiano	SET	The language is set to Italian for menu and message displayed						
		Español	SET	The language is set to Spanish for menu and message displayed						
		Português	SET	The language is set to Portuguese for menu and message displayed						
		日本語	SET	The language is set to Japanese for menu and message displayed						
		中文(简体字)	SET	The language is set to Chinese (Simplified) for menu and message displayed						
		中文(繁體字)	SET	The language is set to Chinese (Traditional) for menu and message displayed						
	한국어	SET	The language is set to Korean for menu and message displayed							
Icon		On	SET	The icon is displayed		Yes (common for all of the inputs)				
		Off	SET	The icon is not displayed						
Menu position		Upper left	SET	The menu is displayed to upper left on the screen		Yes (common for all of the inputs)				
		Upper right	SET	The menu is displayed to upper right on the screen						
		Bottom left	SET	The menu is displayed to bottom left on the screen						
		Bottom right	SET	The menu is displayed to bottom right on the screen						
Menu translucent		On	SET	The menu background becomes translucent		Yes (common for all of the inputs)				
		Off	SET	The menu background in normal state						
Reset	EXEC.	The adjustments and settings of FULL MENU [Display] are returned to the factory default setting		Yes (common for all of the inputs)						

Notes

- Each item can be set at all input sources, but the settings made at one input source are applied to all input sources.
- The adjustments or settings made are memorized automatically when the power is turned off by pressing the **ON/STANDBY** button. If the power cord is unplugged or if a power failure occurs while the projector is on, the adjustments or settings are not memorized.

FULL MENU settings - Default setting

You can set the Input source, projection mode, etc. from FULL MENU [Default setting]. To operate FULL MENU, refer to page 44.

The relationship between input source and item							Yes: Adjustable	-: Not displayed
Analog RGB(1)	Analog RGB(2)	Digital RGB	Y/P _B /P _R	Video	S-Video	Camera		

Input source setting ☑: On/Off with ENTER ⊙: On/Off with (+) or (-)	COMPUTER IN 1	SET	☑: COMPUTER IN 1 connector is selectable by INPUT button	Yes (common for all of the inputs)
	Analog RGB(1)	SET	⊙: Use COMPUTER IN 1 connector as Analog RGB(1) input	
	Y/P _B /P _R	SET	⊙: Use COMPUTER IN 1 connector as Y/P _B /P _R input	
	COMPUTER IN 2	SET	☑: COMPUTER IN 2 connector is selectable by INPUT button	
	Analog RGB(2)	SET	⊙: Use COMPUTER IN 2 connector as Analog RGB(2) input	
	Digital RGB	SET	⊙: Use COMPUTER IN 2 connector as Digital RGB input	
	VIDEO	SET	☑: Video input is selectable by INPUT button	
	S-VIDEO	SET	☑: S-Video input is selectable by INPUT button	
CAMERA	SET	☑: Camera input is selectable by INPUT button		
Projection mode	Standard	SET	The projector placement is set to the floor-mounted front projection mode	Yes (common for all of the inputs)
	Rear	SET	The projector placement is set to the floor-mounted rear projection mode	
	Ceiling	SET	The projector placement is set to the ceiling-mounted front projection mode	
	Rear ceiling	SET	The projector placement is set to the ceiling-mounted rear projection mode	
No signal background	Logo	SET	The TOSHIBA logo is displayed when no signal is input	Yes (common for all of the inputs)
	Blue background	SET	A blue color is displayed at full screen when no signal is input	
	None	SET	Nothing is displayed when no signal is input	
No signal power off	Off	SET	The projector continues work even if the no signal status continues	Yes (common for all of the inputs)
	5 min.	SET	The power turns off automatically if the no signal status continues for approx. 5 min.	
Power on	Manual	SET	The power turns on by pressing the ON/STANDBY button	Yes (common for all of the inputs)
	Auto	SET	When the power cord is plugged, the power turns on	
Startup screen	On	SET	The opening picture is displayed when the power is turned on	Yes (common for all of the inputs)
	Off	SET	The opening picture is not displayed when the power is turned on	
Reset	EXEC.		The settings of FULL MENU [Default setting] are returned to the factory default setting	Yes (common for all of the inputs)

Notes

- It is impossible to exit from the menu if no input source is selected.
- If the check in the check box for the currently selected source is removed, the setting becomes effective the next time the input is changed.
- In the following conditions, the function to detect no signal ("No signal background", "No signal power off") does not act:
 - 1) When "Video mode" 46 is set to other than [Auto] with selection of Video input or S-Video input.
 - 2) When "Signal format" 46 is set to other than [Auto] with selection of Y/P_B/P_R input.
- Note that the projector automatically turns on at the restoration from power failure, if "Power on" is set to [Auto] with the power cord being plugged, even if it is not intended to.
- Even if "Power on" is set to [Auto], the setting of [5 min.] of "No signal power off" is effective.
- Each item can be set at all input sources, but the settings made at one input source are applied to commonness for all input sources.
- The settings made are memorized automatically when the power is turned off by pressing the **ON/STANDBY** button. If the power cord is unplugged or if a power failure occurs while the projector is on, the settings are not memorized.

FULL MENU settings - Reset

- You can return the adjusting and setting value of all menus to the factory default setting. ("H-reference value" below also returns to the value at the factory default setting.)
- The projector stores the standard conditions of horizontal installation, but depending on the usage environment (if the projector is subject to vibrations or shock, etc.), the standard may change.
If the keystone distortion is not corrected properly when "Auto. V-keystone" **35** is executed with the screen installed vertically, put the projector's foot adjustor back **20** and set the projector on a flat surface, then execute "H-reference reset"

Reset all	EXEC.	The adjustments and settings of all menus are returned to the factory default setting
H-reference reset	EXEC.	The horizontal reference value for "Auto. V-keystone" is calibrated automatically

Notes

- If the projector's foot adjuster is used or the projector is included, "H-reference reset" will not be executed properly.
- The settings made are memorized automatically when the power is turned off by pressing the **ON/STANDBY** button. If the power cord is unplugged or if a power failure occurs while the projector is on, the settings are not memorized.

PIP menu setting

When a PIP sub-picture is displayed, the PIP menu screen appears.

You can make the PIP sub-picture settings and the sound settings when a PIP subpicture is displayed.

To cancel the menu, press **EXIT**.

Source	Selecting the signal source for PIP sub-picture	
Video	SET	<input checked="" type="radio"/> : Video input is selected as signal source
S-Video	SET	<input checked="" type="radio"/> : S-Video input is selected as signal source
Size	Setting of the PIP sub-picture size	
Small	SET	<input checked="" type="radio"/> : The PIP sub-picture size is set to small
Middle	SET	<input checked="" type="radio"/> : The PIP sub-picture size is set to middle
Large	SET	<input checked="" type="radio"/> : The PIP sub-picture size is set to large
Position	Setting of the PIP sub-picture display position	
Upper left	SET	<input checked="" type="radio"/> : The sub-picture is displayed to upper left on the screen
Upper right	SET	<input checked="" type="radio"/> : The sub-picture is displayed to upper right on the screen
Bottom left	SET	<input checked="" type="radio"/> : The sub-picture is displayed to bottom left on the screen
Bottom right	SET	<input checked="" type="radio"/> : The sub-picture is displayed to bottom right on the screen
Audio	Selecting the audio input source	
Main	SET	<input checked="" type="radio"/> : The main picture's sound is developed from the speaker
Sub	SET	<input checked="" type="radio"/> : The sub picture's sound is developed from the speaker
Reset	EXEC.	The settings of PIP MENU are returned to the factory default setting

Notes

- The size of the PIP sub-picture changes according to the signal type (resolution) of the main picture.
- When the PIP sub-picture is turned off, the audio input source returns to the previous source (main picture).
- The settings made are memorized automatically when the power is turned off by pressing the **ON/STANDBY** button. If the power cord is unplugged or if a power failure occurs while the projector is on, the settings are not memorized.

Part names (of the document imaging camera model)

CAUTION

When using the camera, be careful not to pinch your hand or fingers into the arm.

On the document imaging camera model, you can project pictures using the document imaging camera. The document imaging camera can directly project any materials (documents, illustrations, etc.) without using an OHP film.

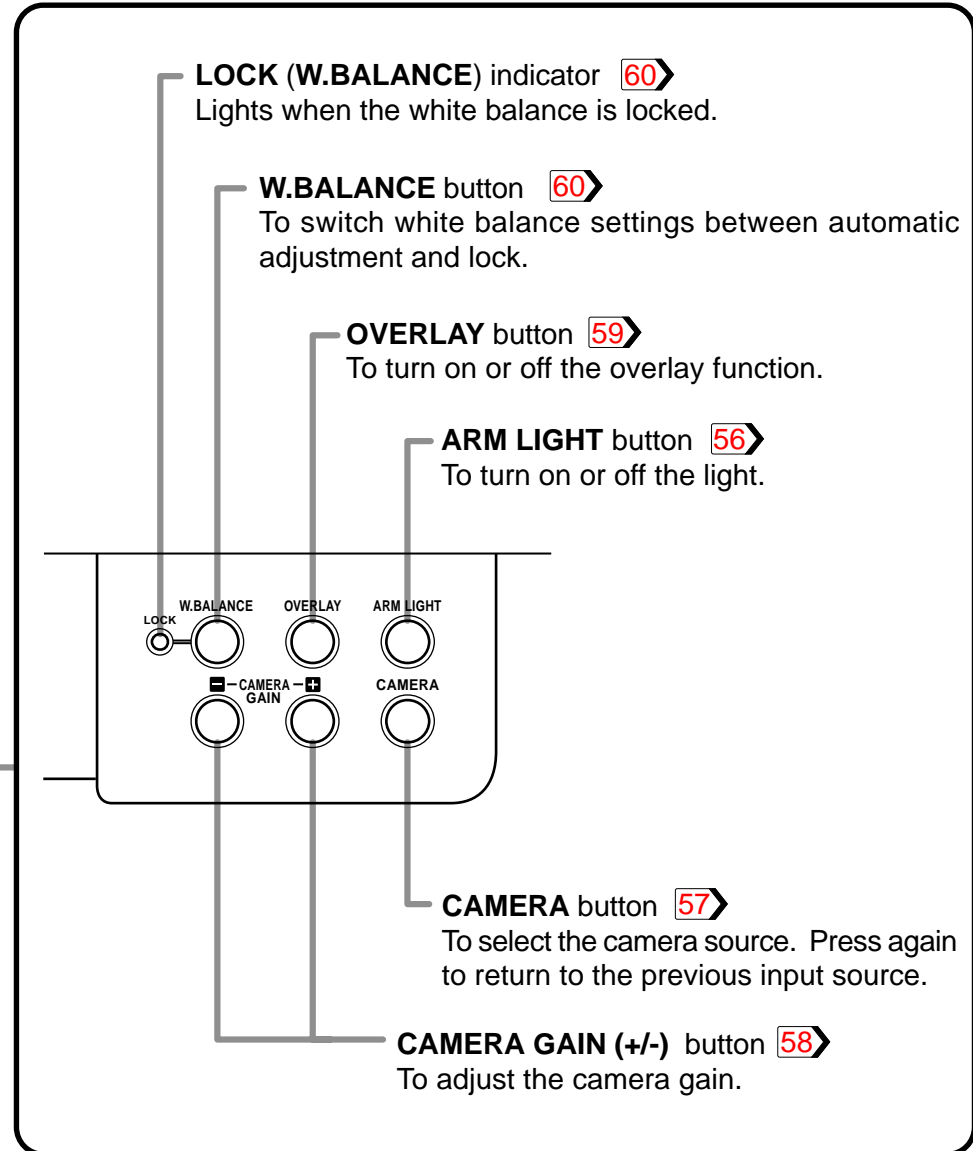
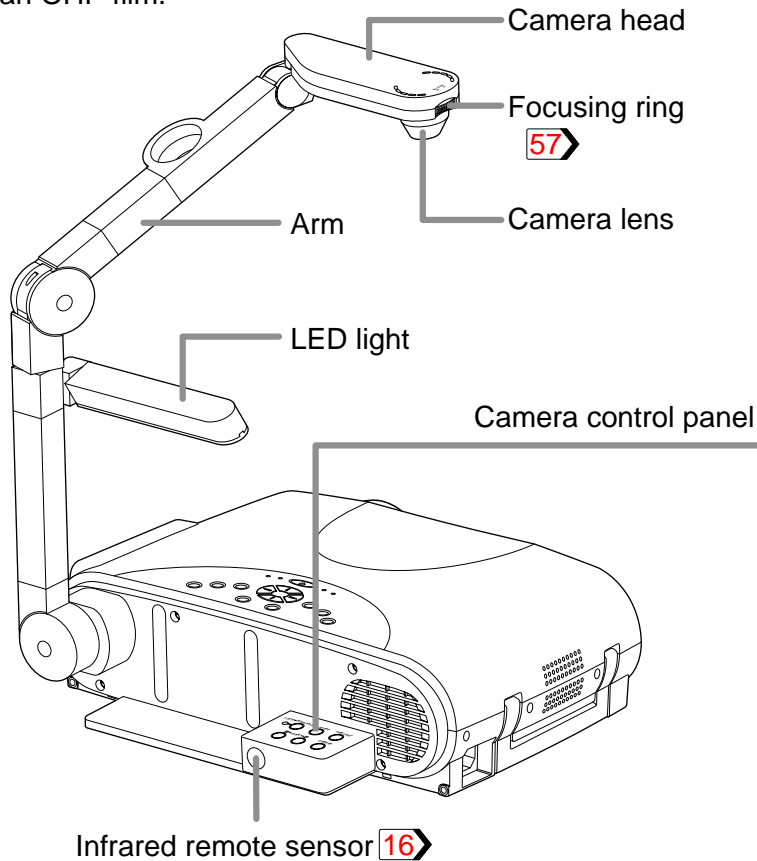

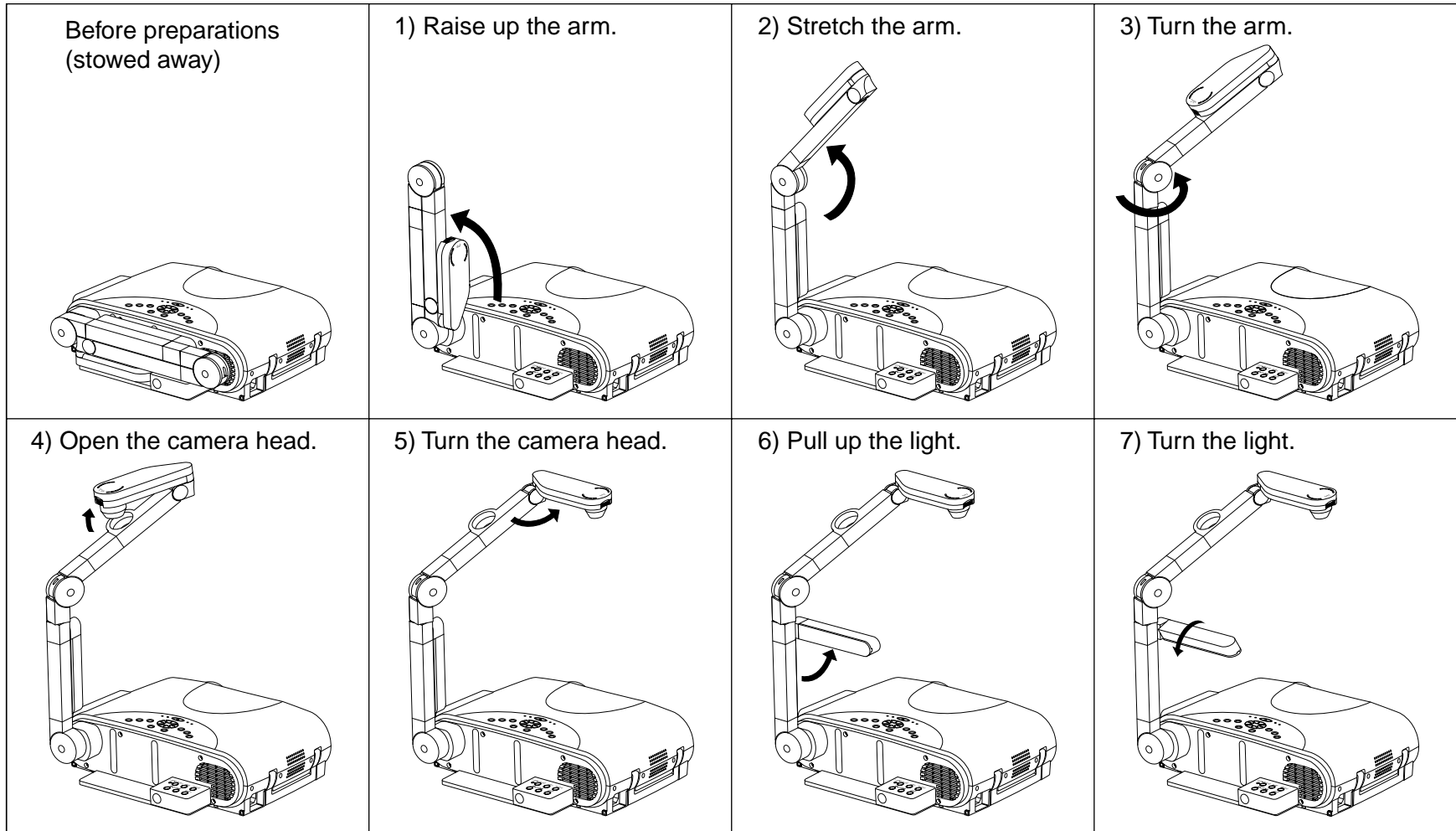

Notes

- Never give shocks or impacts to the camera or arm as this may cause malfunction.
- While raising up or turning the arm, the arm moves describing an arc, be careful not to hit your face or your body.
- The figures above are procedures of putting materials on the projector. When the stability of materials is required, place the materials at the back of the projector and set the arm and camera head for them.

CAUTION

Do not look into the arm light while it is lit.

Camera control panel

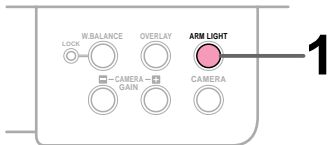
**Preparation**

1 Project a picture on the screen as explained in the step "Projection on the screen". 28

1

ARM LIGHT

**Press ARM LIGHT.**

The light turns on.

2**Set a document to be projected.**

Place the document (illustrations, etc.) onto or around the projector, and turn the camera head to the direction of the document.

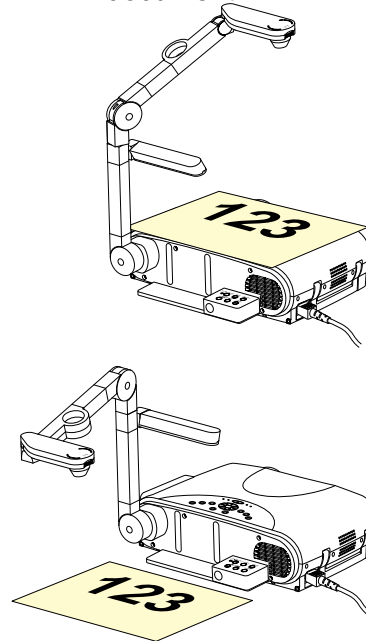

Images on the screen

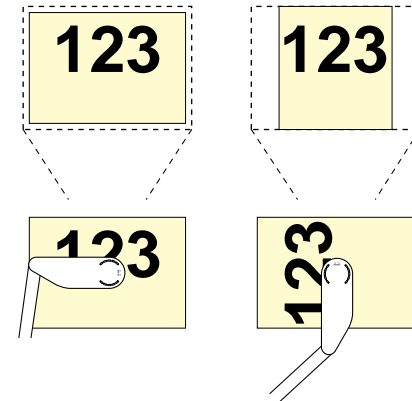

Setting direction

You can also place the materials at the back of the projector and move the arm and the camera head for them.

Notes

- Use the arm light according to the brightness of the room when necessary.
- When setting the materials on the projector, be careful not to press the operation buttons.

Continued

Remote control

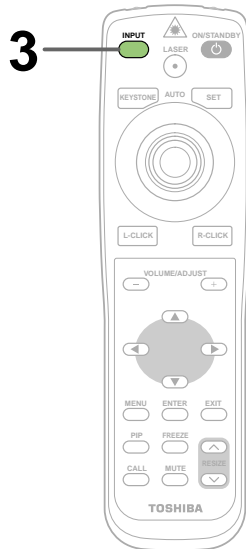

Control panel
(Main unit side)

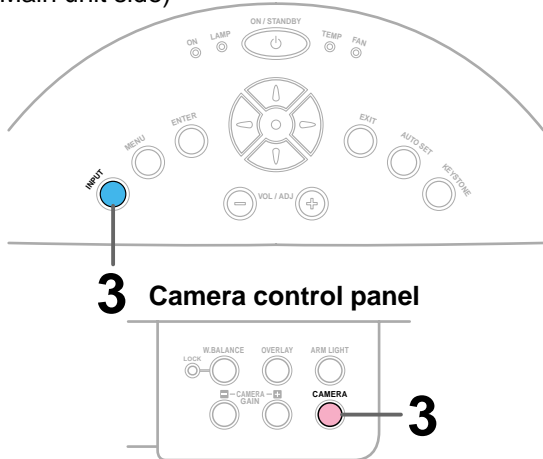

3

CAMERA



INPUT



INPUT



Press CAMERA to select the camera input mode.

- You can also select it by pressing **INPUT** on the remote control or on the main unit. Set the input source on the menu screen when selecting by the **INPUT** button. **30**
- The **CAMERA** button can be used regardless of the input setting.
- "Camera" is displayed when the picture switches to the document imaging camera's picture.

4

Move the camera head to adjust the size of the picture.

↑ Up: To reduce.

↓ Down: To enlarge.

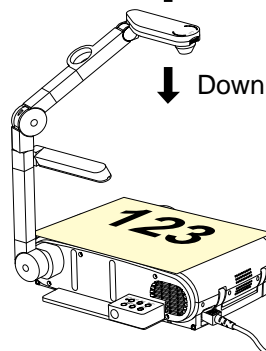

5

Focus on the picture by turning the focusing ring on the camera head.

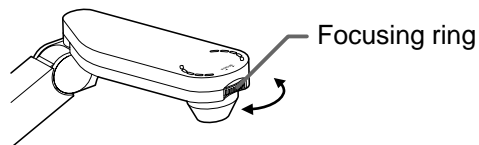

Camera control panel

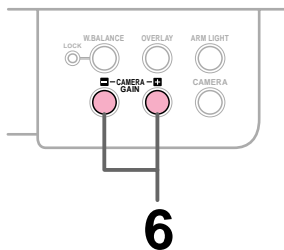

6

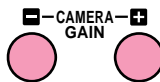

Press **CAMERA GAIN (+/-)** to improve view of a camera subject which is too dark or vivid.

Notes

- You can adjust the "Sharpness" of the camera image on the menu screen. [46](#)
- If the image flickers due to a fluorescent light in the room, either turn off the fluorescent light or set the "Shutter" from the menu screen. [46](#)

Note that the image may still flicker due to the lighting, the document status, the image adjustment, etc., even if the "Shutter" setting is changed.

7

When finished, turn off the light and close it, and put back the arm.

Follow the steps of "Preparation of the document imaging camera" in reverse.

Notes

- Though this projector uses a 1.45 million pixel camera unit, the images projected on the screen are 1024 x 768 dot images. If the "Screen size" in the menu screen [46](#) is set to "Full" the camera's full image is compressed to 1024 x 768 dots. If "Thru" is selected, the 1024 x 768 dots at the center of the image are projected.
- The light turns off automatically when the arm is leaned.
- When the arm is not raised up, the camera source cannot be projected.
- In the camera input selected, audio signals are not output.

You can draw figures or letters with a pen on the picture of RGB input or video input, by using the overlaying function.

Remote control

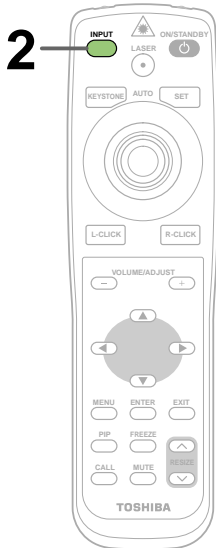

Camera control panel

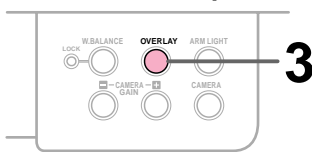

Control panel (Main unit side)

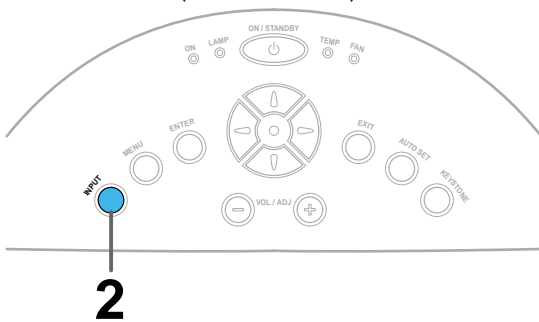

Preparation

- 1 Project a picture on the screen as explained in the step "Picture projection with the document imaging camera". [56](#)
- 2 Prepare white paper and a red or blue pen.

1

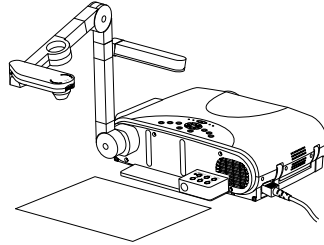

Set the white paper on a flat place and set the camera so that paper is projected to the full screen.

The white paper should be projected fully on the screen.

2

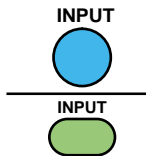

Select the input source using the overlay function by pressing INPUT.

Select the input source other than the camera input.

3



Press OVERLAY

4



Screen

Draw any line on the paper with a red or blue pen.

A drawn line is projected on the screen, overlapped with the picture of the input source.

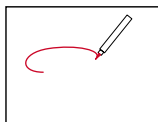

Paper

The position of a pen point can be confirmed on the screen before drawing anything.

Notes

- Handwriting in colors except blue and red cannot be displayed properly.
- Handwriting in fine lines may not be displayed properly.
- The depth overwritten can be adjusted from the menu screen. [46](#)

Camera control panel

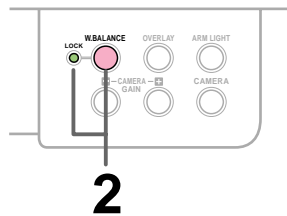

This projector's camera is always being adjusted automatically for projected color balance; however, the balance can shift away from optimal due to the color scheme of the document. Should this occur, the white balance can be set to a fixed condition by using the following procedure.

1

Project a white paper and enlarge it to fill the screen.

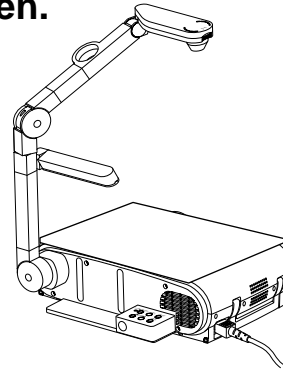

2



Press W.BALANCE to turn the LOCK indicator on.

The white balance is locked.

To release the white balance, press **W.BALANCE** again to turn the LOCK indicator off.

Notes

- If you raise up the arm while the camera input is selected, the color of the picture may vary for an instant due to the automatic white balance adjustment. This is not a malfunction.
- If you put back the arm and raise it up while the white balance is locked (the LOCK indicator is lit), the projector releases the white balance.
- Should this be the case, or if you would like to adjust to a desired tint, adjust "R-level", "G-level" or "B-level" on the FULL MENU [Color] screen.

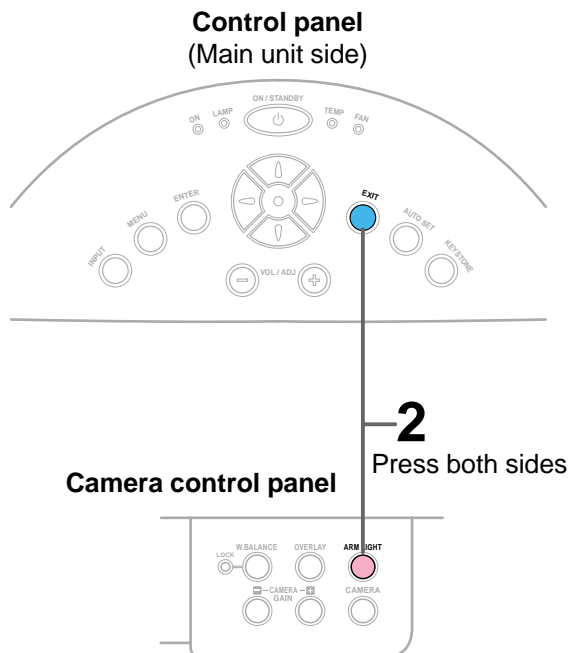

For the CCD image sensor used in the camera unit, in rare cases some of the pixels may be disturbed due to the influence of cosmic rays, etc. This disturbance may cause white spots to appear on the picture.

If white spots appear on the document camera image, use the procedure described below to correct it.

1

With the document camera operating, fully cover the camera lens with a piece of black paper or cloth.

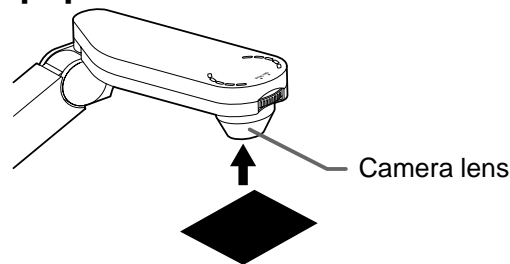
**2**

ARM LIGHT



+

EXIT



Press **ARM LIGHT** on the camera control panel and **EXIT** on the projector's control panel simultaneously.

You can not use the remote control buttons.

Note

- Do not press **ARM LIGHT** and **EXIT** buttons simultaneously if the camera lens is not covered. Doing so will not only erase the white spot correction data already set but also result in parts that are displayed normally being corrected. Also be careful if the camera input mode is not selected.

If there is some problem inside the projector, the indicators light up or blink.

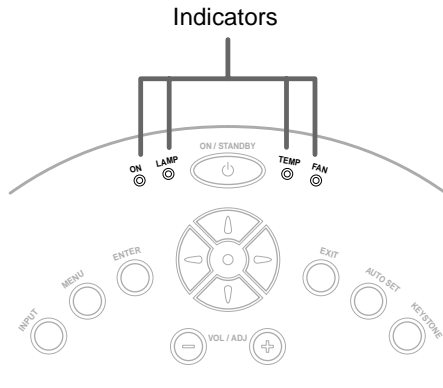

Control panel
(Main unit side)

	<p>The power does not come on.</p> <p>→ Malfunction of the unit.</p> <ul style="list-style-type: none"> • Unplug the power cord and call the dealer.
	<p>The lamp turns off or does not light up.</p> <p>→ The projector will return to the standby mode in about 2 minutes. If the projector does not operate normally when the power is switched on again, the lamp is at the end of its duration life or the unit has a fault.</p> <ul style="list-style-type: none"> • Lamp's duration life is over, replace the lamp with a new one. 66 • Unplug the power cord and call the dealer.
	<p>The power turns off or does not come on.</p> <p>→ The inside is too hot, or the projector has been working in an area of high temperature.</p> <ul style="list-style-type: none"> • Place the projector correctly so the intake and exhaust fan's holes are not covered. • Turn the projector off, and leave it for a while, and turn it on again. • Clean the air filter. 63 <p>* The icon appears before the power turned off.</p> <p>* The projector returns to the standby mode after the fault display has been shown for about 2 minutes.</p>
	<p>The power turns off or does not come on.</p> <p>→ Trouble with the cooling fan.</p> <ul style="list-style-type: none"> • Unplug the power cord and call the dealer. <p>* The icon appears before the power turned off.</p> <p>* The projector returns to the standby mode after the fault display has been shown for about 2 minutes.</p>
	<p>The power turns off or does not come on.</p> <p>→ The lamp cover is not properly attached.</p> <ul style="list-style-type: none"> • Unplug the power cord and reattach the lamp cover. 67 <p>* The icon appears before the power turned off.</p> <p>* The projector returns to the standby mode after the fault display has been shown for about 2 minutes.</p>

Notes

- If abnormality occurs while operating, unplug the power cord.
- When reinserting the power cord before the lamp has cooled, please wait until the lamp has cooled sufficiently before use. When the lamp is at a high temperature, it may not light and the duration life will be shortened.

Air filter cleaning

CAUTION

If you use the projector mounted on the ceiling, ask the dealer to carry out the maintenance such as cleaning.

The filter inside the air filter cover is the part to shut out dusts or dregs.

Do not use the projector with the filter taken off.

We recommend you to clean the air filter frequently. (The cleaning period is once per about 50 hours).

1 Unplug the power cord.

2 Take off the air filter cover.

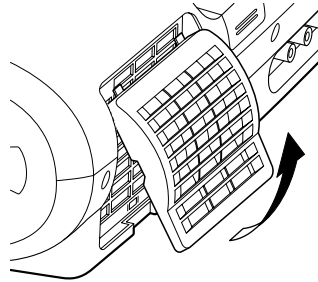

The filter is on the right side of the projector. Pull the bottom side of the cover upward to remove the filter cover.

3 Detach the air filter.

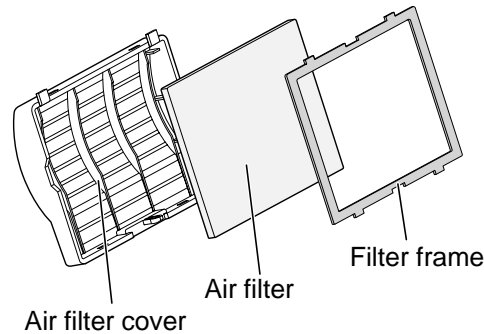

Detach the air filter from the air filter cover. The air filter cover, air filter and filter frame can be disassembled.

4 Clean the air filter.

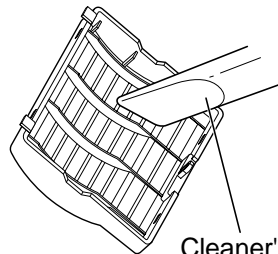

Use a vacuum cleaner to carefully remove any dust and dirt from the air filter cover, air filter and filter frame. Be careful that the air filter is not sucked into the vacuum cleaner.

Notes

- When the air filter is dusty, the ventilation is impaired. This causes the temperature inside the projector to rise, and may damage the unit.
- Attach the air filter cover firmly after the cleaning. If it is not set correctly, the dusts will enter and they will be projected and overlapped on the picture.
- If you wash the air filter with water, be sure to let it dry fully before reinstalling it. Using it damp will result in malfunction.
- If the air filter is damaged, contact your store of purchase and replace it with a new one. Using a damaged air filter will cause dust or dirt to get inside the projector and onto the images.

5

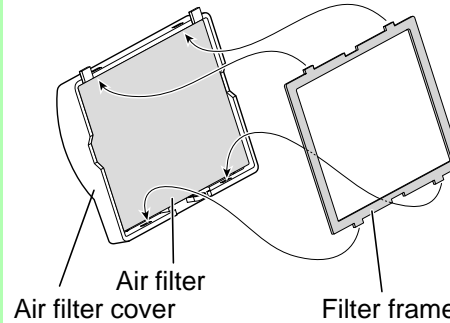

Assemble the air filter.

Place the air filter in the air filter cover, then insert the four tabs on the filter frame into the holes in the air filter cover.

6

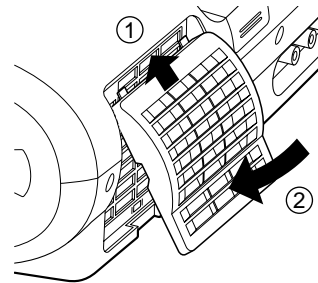

Mount the air filter cover.

Insert the top of the air filter cover into the projector first, then press on the bottom side to install it.

CAUTION

If you use the projector mounted on the ceiling, ask the dealer to carry out the maintenance such as cleaning.

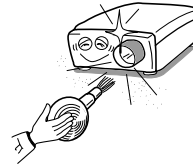

Cleaning the lens

- Use a blower or a lens cleaner to clean the lens.
- Never rub or tap the lens with a hard object as the lens surface is fragile.

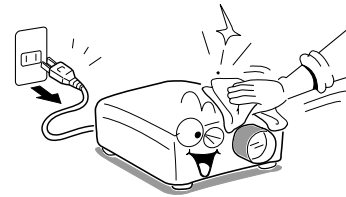

Cleaning the main unit

- Pull out the power cord before cleaning.
- Use a soft cloth to wipe off stains from the surface.
- To remove difficult stains, use a soft cloth slightly moistened with a weak solution of synthetic detergent and water, and finish with a soft, dry cloth.

Replacing the intake, exhaust fans and air filter

To maintain the efficiency of the projector, replace the intake and exhaust fans about every two to three years.

Ask the dealer for the replacement.

The lamp will eventually begin to project dark or dull pictures and finally will not light up.

(Lamp's life length depends on the use condition.)

In such a case, replace the lamp with new one.

CAUTION

- If you use the projector mounted on the ceiling, ask the dealer to carry out the maintenance such as cleaning or replacement of the lamp.
- When replacing, always use lamp "TLPL78" (sold separately). For detail, refer to the lamp instruction.
- If you have been using the projector, the lamp will be very hot, and may cause burn injuries. Wait for the lamp to cool (for longer than 1 hour) before replacing it.
- If the lamp should break, please handle with care to avoid injury due to broken pieces and contact your dealer for repair service.

1 Unplug the power cord.

2 Wait until the lamp gets cold enough.

3 Take off the lamp cover on the bottom panel.
Loosen two screws, and pull off the lamp cover.

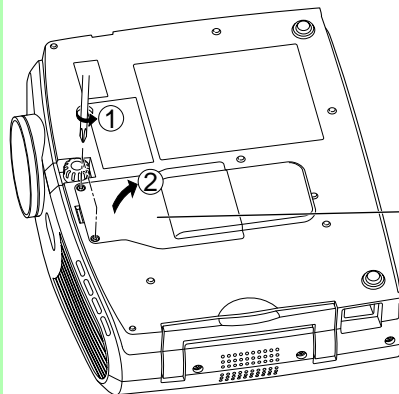

Lamp cover

4 Pull out the lamp.
Loosen the two fixing screws, and lift up the handle to pull out the lamp.

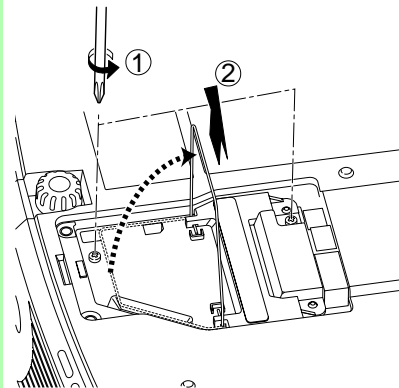

Notes

- When the CALL button is pressed, the "Lamp time" (the approximate amount of time the lamp has been used) is displayed. **41**➤
- The lamp should be replaced if the total working time exceeds about 1,000 hours.
When the "Lamp time" is displayed 1000 hours, the icon  and a message appear. They will disappear when you do some operation.
- Attach the lamp cover firmly after replacing the lamp. If it is not set correctly, the power will not turn on.
- Use a new lamp when replacing it.
- The lamp is made of glass and is very fragile. Do not touch the lamp with your bare hands and do not jolt or damage it. Do not use an exhausted lamp.
- Dispose the exhausted lamp as toxic wastes.

5 Load a new lamp.

Slide until it hits the bottom and tighten the two fixed screws.

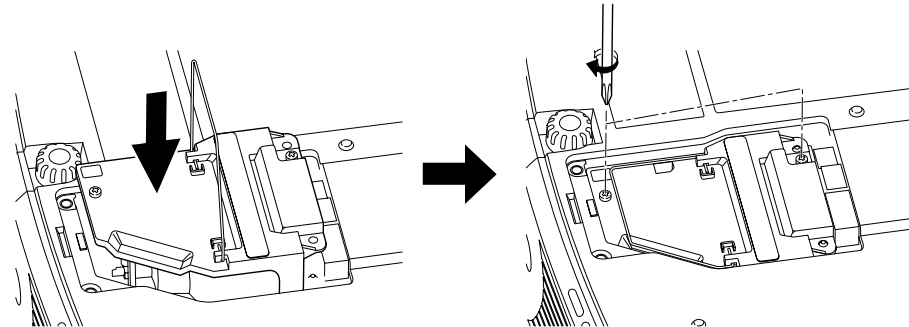

6

Attach the lamp cover.

Slide the cover in place and tighten two screws.

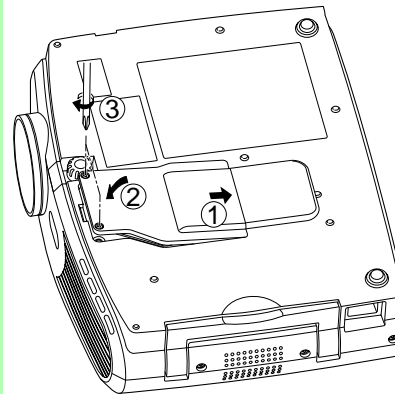

7 Reset the lamp timer.

Refer to the lamp instructions for resetting.

Before calling service personal

Check the following points before asking for support service. Refer also to "Trouble indications". [62](#)

Symptom	Cause	Correction	Page
The power does not come on.	• The power cord is disconnected.	Firmly plug in the power cord.	19
	• The lamp cover is not attached correctly.	Attach the cover correctly.	67
The power turns off while using the projector.	• The ambient temperature of the projection room is too high.	Lower the ambient temperature of the projection room, and turn the power on.	62
No image appears.	• The lens cover is on.	Take off the lens cover.	19
	• The wrong input is selected.	Select the input source correctly.	30
	• The muting mode is on.	Press MUTE to restore the picture.	37
	• The Brightness adjustment is at its darkest.	Make the "Brightness" adjustment.	45
	• The source is not correctly connected to the projector.	Connect the source correctly to the projector.	22 - 25
No sound is heard.	• The wrong input is selected.	Select the input source correctly.	30
	• The muting mode is on.	Press MUTE to restore the sound.	37
	• The sound volume is at the minimum.	Adjust the sound volume.	32
	• The source is not correctly connected to the projector.	Connect the source correctly to the projector.	22 - 25
Desired input source cannot be selected by the INPUT button.	• Input is not set so that it can be selected with the INPUT button. By default, only the Analog RGB(1) and Video input modes can be selected.	Set from the menu screen so that the source can be selected with the INPUT button.	45 30
Analog RGB(1) input or Y/Pb/Pr input colors are not right.	• The COMPUTER IN 1 connector's input setting is wrong.	At the menu screen, set for the proper input signal type.	45
Analog RGB(2) input image does not appear.	• The COMPUTER IN 2 connector's input setting is wrong.	At the menu screen, set for the proper input signal type.	45
	• The signal cable type is wrong.	Use a proper signal cable.	23
Digital RGB input image does not appear.	• The COMPUTER IN 2 connector's input setting is wrong.	At the menu screen, set for the proper input signal type.	45
	• The signal cable type is wrong.	Use a proper signal cable.	23
The image is blurred. Focusing is uneven.	• The lens is dirty.	Clean the lens with a blower or lens cleaner, etc.	65
	• The picture is out of focus.	Focus the picture.	31
	• The projection distance is not appropriate.	Adjust the distance properly.	18
	• The projecting light is not hitting the screen squarely.	Adjust the projecting direction so that the light hits the screen squarely.	18
	• The "Brightness", "Contrast", "Sharpness" or "Phase" adjustments are not correct.	Make the "Picture" adjustments.	45
The picture is dim.	• The "Brightness" or "Contrast" adjustments are not correct.	Make the "Picture" adjustments.	45
	• The lamp life is ending.	Replace the lamp.	66

Continued 

Symptom	Cause	Correction	Page
The color is faint. The tint is not good.	• The "Color", "Tint", "R-Level", "G-Level" or "B-Level" adjustments are not correct.	Make the "Picture" adjustments.	48
	• The lamp life is ending.	Replace the lamp.	66
The remote control does not work.	• The remote control is not facing the remote sensor.	Face the remote control transmitter toward the remote sensor on the projector.	16
	• The remote control is too far.	Operate within about 5 meters.	16
	• There is an obstruction between the remote control and the remote sensor.	Remove the obstacle.	-
	• The batteries are exhausted.	Replace the batteries.	15
Mouse function cannot be used from the remote control unit.	• The USB cable is not properly connected.	Connect the USB cable properly.	39
	• The computer or OS is not compatible.	The remote control mouse function is not available.	-
	• The batteries are exhausted.	Replace the batteries.	15
Document camera image is blurry.	• The lens is dirty.	Clean the lens with a blower or lens cleaner, etc.	65
	• The picture is out of focus.	Focus the picture by turning the focus ring.	57
	• The light is not on.	Turn on the light.	56
Document camera image flickers.	• Image is being affected by fluorescent light in the room.	Set the shutter speed on the menu screen.	45
Document camera image movement is awkward.	• The image's number of frames is low. This is not a malfunction.		
Horizontal stripes appear when document projected with the document camera is moved.	• The image's number of frames is low. This is not a malfunction.		

Pin assignment of COMPUTER IN, MONITOR OUT connector

COMPUTER IN 1 MONITOR OUT

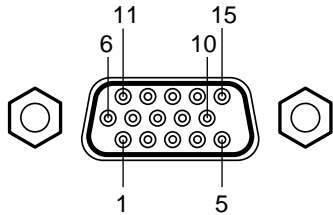

Input signal
 Analog R, G, B signal: 0.7V(p-p) 75Ω
 Horizontal sync signal:
 TTL level (positive/negative polarity)
 Vertical sync signal:
 TTL level (positive/negative polarity)
 Y signal: 1.0V(p-p) 75Ω
 P_B, P_R signal: 0.7V(p-p) 75Ω

Mini D-sub 15pinconnector

COMPUTER IN 2

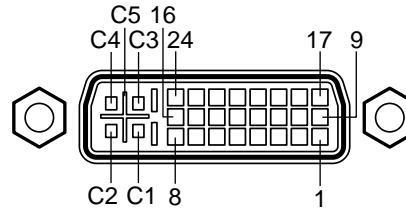

Analog input signal
 Analog R, G, B signal: 0.7V(p-p) 75Ω
 Horizontal sync signal:
 TTL level (positive/negative polarity)
 Vertical sync signal:
 TTL level (positive/negative polarity)

DVI ANALOG & DIGITALconnector

Pin No.	Description	
	RGB input	Y/P _B /P _R input
1	Video signal (Red)	Color difference signal (P _R)
2	Video signal (Green)	Luminance signal (Y)
3	Video signal (Blue)	Color difference signal (P _B)
4	GND	*
5	GND	*
6	GND (Red)	GND (P _R)
7	GND (Green)	GND (Y)
8	GND (Blue)	GND (P _B)
9	N.C	*
10	GND	*
11	GND	*
12	DDC data	*
13	Horizontal sync signal	*
14	Vertical sync signal	*
15	DDC clock	*

Pin No.	Description	Pin No.	Description
1	T.M.D.S. data 2 -	16	Hot plug detection
2	T.M.D.S. data 2 +	17	T.M.D.S. data 0 -
3	T.M.D.S. data 2/4 shield	18	T.M.D.S. data 0 +
4	T.M.D.S. data 4 -	19	T.M.D.S. data 0/5 shield
5	T.M.D.S. data 4 +	20	T.M.D.S. data 5 -
6	DDC clock	21	T.M.D.S. data 5 +
7	DDC data	22	T.M.D.S. clock shield
8	Analog vertical sync signal	23	T.M.D.S. clock +
9	T.M.D.S. data 1 -	24	T.M.D.S. clock -
10	T.M.D.S. data 1 +	C1	Analog Video signal (Red)
11	T.M.D.S. data 1/3 shield	C2	Analog Video signal (Green)
12	T.M.D.S. data 3 -	C3	Analog Video signal (Blue)
13	T.M.D.S. data 3 +	C4	Analog horizontal sync signal
14	+5V power	C5	Analog GND (R,G & B)
15	GND (+5V, H Sync & V Sync)		

*: Do not connect anything.

Applicable signal

Applicable computer signal

The unit is applicable to the following signals. However, some computers may have different timings than those in the chart.

Make the necessary adjustments if the picture has flickers or is blurred.

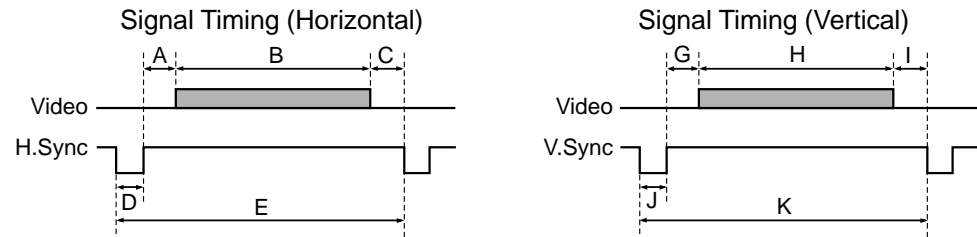

Timing chart

Mode	Resolution	A (pixels)	B (pixels)	C (pixels)	D (pixels)	E (pixels)	fh (kHz)	fv (Hz)	clock (MHz)	G (Lines)	H (Lines)	I (Lines)	J (Lines)	K (Lines)
TEXT70	640 x 350	50	640	14	96	800	31.469	70.086	25.175	59	350	38	2	449
TEXT70	640 x 400	50	640	14	96	800	31.469	70.086	25.175	34	400	13	2	449
TEXT85	640 x 350	96	640	32	64	832	37.861	85.080	31.500	60	350	32	3	445
TEXT85	640 x 400	96	640	32	64	832	37.861	85.080	31.500	41	400	1	3	445
NEC PC98 24k	640 x 400	85	640	59	64	848	24.820	55.900	21.047	25	400	11	8	444
VGA60	640 x 480	48	640	16	96	800	31.469	59.940	25.175	33	480	10	2	525
VGA72	640 x 480	128	640	24	40	832	37.861	72.809	31.500	28	480	9	3	520
VGA75	640 x 480	120	640	16	64	840	37.500	75.000	31.500	16	480	1	3	500
VGA85	640 x 480	80	640	56	56	832	43.269	85.008	36.000	25	480	1	3	509
MAC13"	640 x 480	96	640	64	64	864	35.000	66.667	30.240	39	480	3	3	525
SVGA56	800 x 600	128	800	24	72	1024	35.156	56.250	36.000	22	600	1	2	625
SVGA60	800 x 600	88	800	40	128	1056	37.879	60.317	40.000	23	600	1	4	628
SVGA72	800 x 600	64	800	56	120	1040	48.077	72.188	50.000	23	600	37	6	666
SVGA75	800 x 600	160	800	16	80	1056	46.875	75.000	49.500	21	600	1	3	625
SVGA85	800 x 600	152	800	32	64	1048	53.674	85.061	56.250	27	600	1	3	631
MAC16"	832 x 624	216	832	40	64	1152	49.725	74.550	57.283	39	632	1	3	667
XGA43i	1024 x 768	56	1024	8	176	1264	35.522	43.479	44.900	20	768	0	4	817
XGA60	1024 x 768	160	1024	24	136	1344	48.363	60.004	65.000	29	768	3	6	806
XGA70	1024 x 768	144	1024	24	136	1328	56.476	70.069	75.000	29	768	3	6	806
XGA75	1024 x 768	176	1024	16	96	1312	60.023	75.029	78.750	28	768	1	3	800
XGA85	1024 x 768	208	1024	48	96	1376	68.677	84.997	94.500	36	768	1	3	808
MAC19"	1024 x 768	180	1024	20	96	1320	60.197	74.872	73.200	30	768	3	3	804

Continued

Timing chart (Continued)

Mode	Resolution	A (pixels)	B (pixels)	C (pixels)	D (pixels)	E (pixels)	fh (kHz)	fv (Hz)	clock (MHz)	G (Lines)	H (Lines)	I (Lines)	J (Lines)	K (Lines)
*SXGA1152x864 75Hz	1152 x 864	256	1152	64	128	1600	67.500	75.000	108.000	32	864	1	3	900
*SXGA1280x960 60Hz	1280 x 960	312	1280	96	112	1800	60.000	60.000	108.000	36	960	1	3	1000
*SXGA1280x960 85Hz	1280 x 960	224	1280	64	160	1728	85.938	85.002	148.500	47	960	1	3	1011
*SXGA1280x1024 60Hz	1280 x 1024	248	1280	48	112	1688	63.981	60.020	108.000	38	1024	1	3	1066
*SXGA1280x1024 75Hz	1280 x 1024	248	1280	16	144	1688	79.976	75.025	135.000	38	1024	1	3	1066
*SXGA1280x1024 85Hz	1280 x 1024	224	1280	64	160	1728	91.146	85.024	157.500	44	1024	1	3	1072
*UXGA60	1600 x 1200	304	1600	64	192	2160	75.000	60.000	162.000	46	1200	1	3	1250
*UXGA65	1600 x 1200	304	1600	64	192	2160	81.250	65.000	175.500	46	1200	1	3	1250
*UXGA70	1600 x 1200	304	1600	64	192	2160	87.500	70.000	189.000	46	1200	1	3	1250
*UXGA75	1600 x 1200	304	1600	64	192	2160	93.750	75.000	202.500	46	1200	1	3	1250

Notes

- Signal sources marked "*" are displayed in compressed format, so some of their data may be missing or their picture quality may be degraded.
- With analog RGB inputs, if the signal source's dot clock frequency exceeds 165 MHz, not all of the pixel signals can be sampled.
- For digital RGB inputs, the projector is not compatible with signal sources whose dot clock frequency exceeds 162 MHz.

The compatible Video and S-Video signal

Mode	fh(kHz)	fv(Hz)	fsc(MHz)
NTSC	15.73	60	3.58
PAL	15.63	50	4.43
SECAM	15.63	50	4.25 or 4.41
PAL-M	15.73	60	3.58
PAL-N	15.63	50	3.58
PAL-60	15.73	60	4.43
NTSC4.43	15.73	60	4.43

The compatible components video signal (Y/Pb/Pr)

Mode	fh(kHz)	fv(Hz)
525i	15.73	59.94
525p	31.47	59.94
625i	15.63	50.00
750p	45.00	60.00
1125i	33.75	60.00

Controlling the projector by using RS-232C

You can also control the projector by entering the command from a computer via RS-232C.

Signal assignment of RS-232C

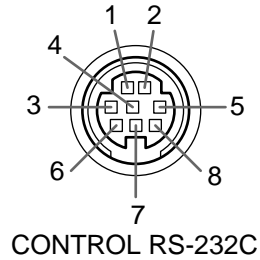

Pin No.	Signal	Description
1	RXD	Receiving data
2	CTS	Consent to send
3	DSR	Data set ready
4	GND	Signal ground
5	RTS	Request to send
6	N.C	No connection
7	TXD	Sending data
8	N.C	No connection

Interface format

1. Communication method: RS-232C
9600 bps, No parity, Data length: 8 bit, Stop bit: 1 bit
2. Communication format:

STX (02h)	Command (3 bite)	ETX (03h)
-----------	------------------	-----------

One command only can be used in one communication.
3. Data format: Command shall be composed of alphanumeric characters of ASCII description. Use only capital letters.
4. Return value: Acknowledge

ACK (06h)

Not Acknowledge

NAK (15h)

Command list

Classification	Items/Status	Selection Command	Adjustment Command	Analog RGB(1) Analog RGB(2)	Digital RGB	Video S-Video	Y/Pb/Pr	Camera	
Power	On	PON	-	Yes	Yes	Yes	Yes	Yes	
	Off (with confirmation message)	POF	-	Yes	Yes	Yes	Yes	Yes	
	Shut Down (without confirmation message)	PSD	-	Yes	Yes	Yes	Yes	Yes	
Normal (RS-232C Condition Display Off)		DOF	-	Yes	Yes	Yes	Yes	Yes	
Picture	Contrast	VCN	Yes	Yes	Yes	Yes	Yes	Yes	
	Brightness	VBR	Yes	Yes	Yes	Yes	Yes	Yes	
	Sharpness	VSH	Yes	-	-	Yes	Yes	Yes	
	Camera gain	Increase	CGU	-	-	-	-	-	Yes
		Decrease	CGD	-	-	-	-	-	Yes
	Picture mode	Bright	MVB	-	Yes	Yes	-	-	-
True color		MVP	-	Yes	Yes	-	-	-	

Notes

- When commands are transmitted serially, wait the reply of the projector (acknowledge or not acknowledge) before sending a next command.
- Adjustment commands include "ARG" (increase adjustment value) and "ALF" (decrease adjustment value). For usable items (marked "Yes"), send after the selection command.
- The "Yes" marks in the input source columns indicate that that command can be used.

Continued

Controlling the projector by using RS-232C (continued)

Classification	Items/Status	Selection Command	Adjustment Command	Analog RGB(1) Analog RGB(2)	Digital RGB	Video S-Video	Y/PB/PR	Camera	
Picture (Continued)	Video mode	Auto.	KV0	-	-	-	Yes	-	
		NTSC	KV1	-	-	-	Yes	-	
		PAL	KV2	-	-	-	Yes	-	
		SECAM	KV3	-	-	-	Yes	-	
		PAL-N	KV4	-	-	-	Yes	-	
		PAL-M	KV5	-	-	-	Yes	-	
		PAL60	KV6	-	-	-	Yes	-	
	NTSC4.43	KV7	-	-	-	Yes	-		
	Signal format	Auto.	SG0	-	-	-	-	Yes	-
		525i	SG1	-	-	-	-	Yes	-
		525p	SG2	-	-	-	-	Yes	-
		625i	SG3	-	-	-	-	Yes	-
		750p	SG4	-	-	-	-	Yes	-
	Shutter	1125i	SG5	-	-	-	-	Yes	-
		Auto.	CSA	-	-	-	-	-	Yes
		50Hz	CS0	-	-	-	-	-	Yes
	Screen size	60Hz	CS1	-	-	-	-	-	Yes
		Full	MSF	-	Yes	Yes	Yes	Yes	Yes
		Thru	MST	-	Yes	Yes	Yes	Yes	Yes
	Overlay gain	Wide	MSW	-	-	-	Yes	Yes	-
		Picture reset	COG	Yes	Yes	Yes	Yes	Yes	-
Position	Picture reset	DRV	-	Yes	Yes	Yes	Yes	Yes	
	H-position	PHP	Yes	Yes	-	-	-	-	
	V-position	PVP	Yes	Yes	-	-	-	-	
	Phase	PPH	Yes	Yes	-	-	-	-	
	Frequency	PCK	Yes	Yes	-	-	-	-	
	Position reset	DRP	-	-	Yes	-	-	-	

Controlling the projector by using RS-232C (continued)

Classification	Items/Status		Selection Command	Adjustment Command	Analog RGB(1) Analog RGB(2)	Digital RGB	Video S-Video	Y/Pb/Pr	Camera	
Color	Color		VCL	Yes	-	-	Yes	Yes	-	
	Tint		VTN	Yes	-	-	Yes *	Yes	-	
	R-level		VLR	Yes	Yes	Yes	Yes	Yes	Yes	
	G-level		VLG	Yes	Yes	Yes	Yes	Yes	Yes	
	B-level		VLB	Yes	Yes	Yes	Yes	Yes	Yes	
	Color reset		DRC	-	Yes	Yes	Yes	Yes	Yes	
Audio	Volume	Increase	VLU	-	Yes	Yes	Yes	Yes	-	
		Decrease	VLD	-	Yes	Yes	Yes	Yes	-	
	Speaker output	On	AS1	-	Yes	Yes	Yes	Yes	-	
		Off	AS0	-	Yes	Yes	Yes	Yes	-	
	Channel select (RCA)	L+R	APA	-	-	-	Yes	-	-	
		L	APL	-	-	-	Yes	-	-	
		R	APR	-	-	-	Yes	-	-	
	Loudness (RCA)	Off	LR0	-	-	-	Yes	-	-	
		On	LR1	-	-	-	Yes	-	-	
	Channel select (Mini)	L+R	AMA	-	Yes	Yes	-	Yes	-	
		L	AML	-	Yes	Yes	-	Yes	-	
		R	AMR	-	Yes	Yes	-	Yes	-	
	Loudness (Mini)	Off	LM0	-	Yes	Yes	-	Yes	-	
		On	LM1	-	Yes	Yes	-	Yes	-	
	Audio reset		DRA	-	Yes	Yes	Yes	Yes	-	
	Display	V-keystone		PKV	Yes	Yes	Yes	Yes	Yes	Yes
H-keystone		PKH	Yes	Yes	Yes	Yes	Yes	Yes		
Keystone reset		DRK	-	Yes	Yes	Yes	Yes	Yes		
Language		English		LEN	-	Yes	Yes	Yes	Yes	Yes
		French		LFR	-	Yes	Yes	Yes	Yes	Yes
		German		LGR	-	Yes	Yes	Yes	Yes	Yes
		Italian		LIT	-	Yes	Yes	Yes	Yes	Yes
		Spanish		LSP	-	Yes	Yes	Yes	Yes	Yes
		Portuguese		LPO	-	Yes	Yes	Yes	Yes	Yes
		Japanese		LJP	-	Yes	Yes	Yes	Yes	Yes
		Chinese(Simplified)		LPK	-	Yes	Yes	Yes	Yes	Yes
		Chinese(Traditional)		LKT	-	Yes	Yes	Yes	Yes	Yes
		Korean		LKK	-	Yes	Yes	Yes	Yes	Yes

* Not possible for PAL/SECAM.

Controlling the projector by using RS-232C (continued)

Classification	Items/Status		Selection Command	Adjustment Command	Analog RGB(1) Analog RGB(2)	Digital RGB	Video S-Video	Y/P _B /P _R	Camera	
Display (Continued)	Icon	On	MO0	-	Yes	Yes	Yes	Yes	Yes	
		Off	MO1	-	Yes	Yes	Yes	Yes	Yes	
	Menu position	Upper left	MP1	-	Yes	Yes	Yes	Yes	Yes	
		Bottom left	MP2	-	Yes	Yes	Yes	Yes	Yes	
		Upper right	MP3	-	Yes	Yes	Yes	Yes	Yes	
		Bottom right	MP4	-	Yes	Yes	Yes	Yes	Yes	
		Menu translucent	On	MB1	-	Yes	Yes	Yes	Yes	Yes
		Off	MB0	-	Yes	Yes	Yes	Yes	Yes	
	Display reset (except keystone)		DRD	-	Yes	Yes	Yes	Yes	Yes	
	Default setting	Input source setting	COMPUTER IN 1	On	I10	-	Yes	Yes	Yes	Yes
Off				I11	-	Yes	Yes	Yes	Yes	
Analog RGB(1)				IS0	-	Yes	Yes	Yes	Yes	
Y/P _B /P _R				IS1	-	Yes	Yes	Yes	Yes	
COMPUTER IN 2			On	I20	-	Yes	Yes	Yes	Yes	Yes
			Off	I21	-	Yes	Yes	Yes	Yes	Yes
			Analog RGB(2)	IV0	-	Yes	Yes	Yes	Yes	Yes
			Digital RGB	IV1	-	Yes	Yes	Yes	Yes	Yes
VIDEO			On	I30	-	Yes	Yes	Yes	Yes	Yes
			Off	I31	-	Yes	Yes	Yes	Yes	Yes
S-VIDEO			On	I40	-	Yes	Yes	Yes	Yes	Yes
			Off	I41	-	Yes	Yes	Yes	Yes	Yes
CAMERA		On	I60	-	Yes	Yes	Yes	Yes	Yes	
		Off	I61	-	Yes	Yes	Yes	Yes	Yes	
Projection mode		Standard	PJ0	-	Yes	Yes	Yes	Yes	Yes	
		Rear	PJ1	-	Yes	Yes	Yes	Yes	Yes	
		Ceiling	PJ2	-	Yes	Yes	Yes	Yes	Yes	
		Rear ceiling	PJ3	-	Yes	Yes	Yes	Yes	Yes	
		No signal background	Logo	BG0	-	Yes	Yes	Yes	Yes	Yes
		Blue background	BG1	-	Yes	Yes	Yes	Yes	Yes	
		Non	BG2	-	Yes	Yes	Yes	Yes	Yes	
No signal power off		Off	PN0	-	Yes	Yes	Yes	Yes	Yes	
		5 min.	PN1	-	Yes	Yes	Yes	Yes	Yes	
Power on		Manual	AP0	-	Yes	Yes	Yes	Yes	Yes	
		Auto.	AP1	-	Yes	Yes	Yes	Yes	Yes	

Controlling the projector by using RS-232C (continued)

Classification	Items/Status		Selection Command	Adjustment Command	Analog RGB(1) Analog RGB(2)	Digital RGB	Video S-Video	Y/P _B /P _R	Camera
Default setting (Continued)	Startup screen	On	MS0	-	Yes	Yes	Yes	Yes	Yes
		Off	MS1	-	Yes	Yes	Yes	Yes	Yes
	Default setting reset		DRI	-	Yes	Yes	Yes	Yes	Yes
Reset	Reset all		DRS	-	Yes	Yes	Yes	Yes	Yes
	H-reference reset		PKR	-	Yes	Yes	Yes	Yes	Yes
Status display (CALL)			DON	-	Yes	Yes	Yes	Yes	Yes
Input selection	Toggle		IN0	-	Yes	Yes	Yes	Yes	Yes
	COMPUTER-1		IN1	-	Yes	Yes	Yes	Yes	Yes
	COMPUTER-2		IN2	-	Yes	Yes	Yes	Yes	Yes
	VIDEO		IN3	-	Yes	Yes	Yes	Yes	Yes
	S-VIDEO		IN4	-	Yes	Yes	Yes	Yes	Yes
	CAMERA		IN6	-	Yes	Yes	Yes	Yes	Yes
RESIZE	Increase the enlargement ratio		RUP	-	Yes	Yes	Yes	Yes	Yes
	Decrease the enlargement ratio (Minimum: reset status)		RDW	-	Yes	Yes	Yes	Yes	Yes
	Move the enlargement section	Up	PO1	-	Yes	Yes	Yes	Yes	Yes
		Down	PO2	-	Yes	Yes	Yes	Yes	Yes
		Left	PO3	-	Yes	Yes	Yes	Yes	Yes
		Right	PO4	-	Yes	Yes	Yes	Yes	Yes
	Enlargement reset		RS0	-	Yes	Yes	Yes	Yes	Yes
FREEZE	On		FON	-	Yes	Yes	Yes	Yes	Yes
	Off		FOF	-	Yes	Yes	Yes	Yes	Yes
MUTE	On		MON	-	Yes	Yes	Yes	Yes	Yes
	Off		MOF	-	Yes	Yes	Yes	Yes	Yes
PIP	On		PIN	-	Yes	Yes	-	-	-
	Off		PIF	-	Yes	Yes	-	-	-
	PIP input source	Video	PI0	-	Yes	Yes	-	-	-
		S-Video	PI1	-	Yes	Yes	-	-	-
	PIP size	Small	PS0	-	Yes	Yes	-	-	-
		Middle	PS1	-	Yes	Yes	-	-	-
		Large	PS2	-	Yes	Yes	-	-	-
	PIP position	Upper left	PP0	-	Yes	Yes	-	-	-
		Upper right	PP1	-	Yes	Yes	-	-	-
		Bottom left	PP2	-	Yes	Yes	-	-	-
Bottom right		PP3	-	Yes	Yes	-	-	-	

Controlling the projector by using RS-232C (continued)

Classification	Items/Status		Selection Command	Adjustment Command	Analog RGB(1) Analog RGB(2)	Digital RGB	Video S-Video	Y/PB/PR	Camera
PIP (Continued)	PIP audio source	Main	PA0	-	Yes	Yes	-	-	-
		Sub	PA1	-	Yes	Yes	-	-	-
	PIP reset		DRW	-	Yes	Yes	-	-	-
AUTO SET			PAT	-	Yes	-	-	-	-
Auto. V-keystone			PKA	-	Yes	Yes	Yes	Yes	Yes
Overlay	On		CON	-	Yes	Yes	Yes	Yes	-
	Off		COF	-	Yes	Yes	Yes	Yes	-
Camera	Shortcut		CDR	-	Yes	Yes	Yes	Yes	Yes
	Auto. W/B	On	CW1	-	Yes	Yes	Yes	Yes	Yes
		Off	CW0	-	Yes	Yes	Yes	Yes	Yes
	Lighting	On	CL1	-	Yes	Yes	Yes	Yes	Yes
		Off	CL0	-	Yes	Yes	Yes	Yes	Yes

Main unit

Power consumption	TLP780: 300 W (Standby: 20W) TLP781: 310 W (Standby: 20W)
Mass	TLP780: 4.2 kg TLP781: 5.0 kg
Dimensions (Except the protrusion parts)	TLP780: 338 x 95.5 x 265 (mm) (W/H/D) TLP781: 338 x 95.5 x 328 (mm) (W/H/D)
Cabinet Material	PC+ABS resin and ABS resin
Ambient environment	Temperature : 0 deg. to 35 deg. Humidity : 30% to 70% RH
Lamp	High pressure mercury lamp
Projection screen size	32 to 300 inches
Projection distance	1.42 to 11.1 m
Speaker	1W (monaural)
Connectors	
• COMPUTER IN 1	Mini D-sub 15-pin Analog RGB(1)/Y/P _B /P _R (combination)
• COMPUTER IN 2	DVI ANALOG & DIGITAL connector Analog RGB(2)/Digital RGB (combination)
• MONITOR OUT	Mini D-sub 15-pin Analog RGB/Y/P _B /P _R (combination)
• S-VIDEO IN	Mini DIN 4-pin
• VIDEO IN	1V(p-p), 75Ω, RCA pin jack
• AUDIO(L/R) IN	1.3V(rms), more than 22kΩ, RCA pin jack x 2
• AUDIO IN	1.3V(rms), more than 22kΩ, φ3.5mm stereo mini jack
• CONTROL	Mini DIN 8-pin (RS-232C)
• USB	Type B

Liquid crystal display

Projection system	3-panels transmission
Panel size	0.9 inches
Driving system	TFT active matrix
Picture elements	786,432 pixels (1024 x 768 dots) (H./V.) x 3

Projection lens

Lens	Zooming lens F=1.7 to 2.1 f=33.6 to 42mm
Focusing	Manual operation
Zooming	Manual operation

Document imaging camera (with camera model)

Lens	F = 3.1, f = 6.4mm
Focusing	Manual operation
Zoom	None (adjusted by distance to subject)
Iris	Auto./Manual
Image element	1/2 inch CCD
Effective pixels for pickup section	1,447,680 pixels (1392 x 1040 dots) (H./V.)
Lighting	LED light

Accessories

Owner's manual (Getting started)	1
Owner's manual (CD-ROM)	1
Remote control	1
R6 (AA) size battery	2
Power cord	1
RGB cable	1 (3m)
DVI analog cable	1 (2m)
Adapter for Macintosh computers	1
AV cable	1 (3m)
Audio cable (for Computer)	1 (3m)
Control cable	1 (1.8m)
USB cable	1 (2m)
Carrying case	1

Sold separately

Replacement lamp TLPL78

- The design and specifications are subject to change without notice.

Trademarks

NEC, PC-98 series are trademarks of NEC Corporation.

VGA, SVGA, XGA, SXGA, UXGA are trademarks or registered trademarks of International Business Machines Corporation.

Macintosh is a registered trademark of Apple Computer, Inc.

Windows is a registered trademark of Microsoft Corporation in the U.S. and other countries.

Display Data Channel is a trademark of Video Electronics Standard Association.